

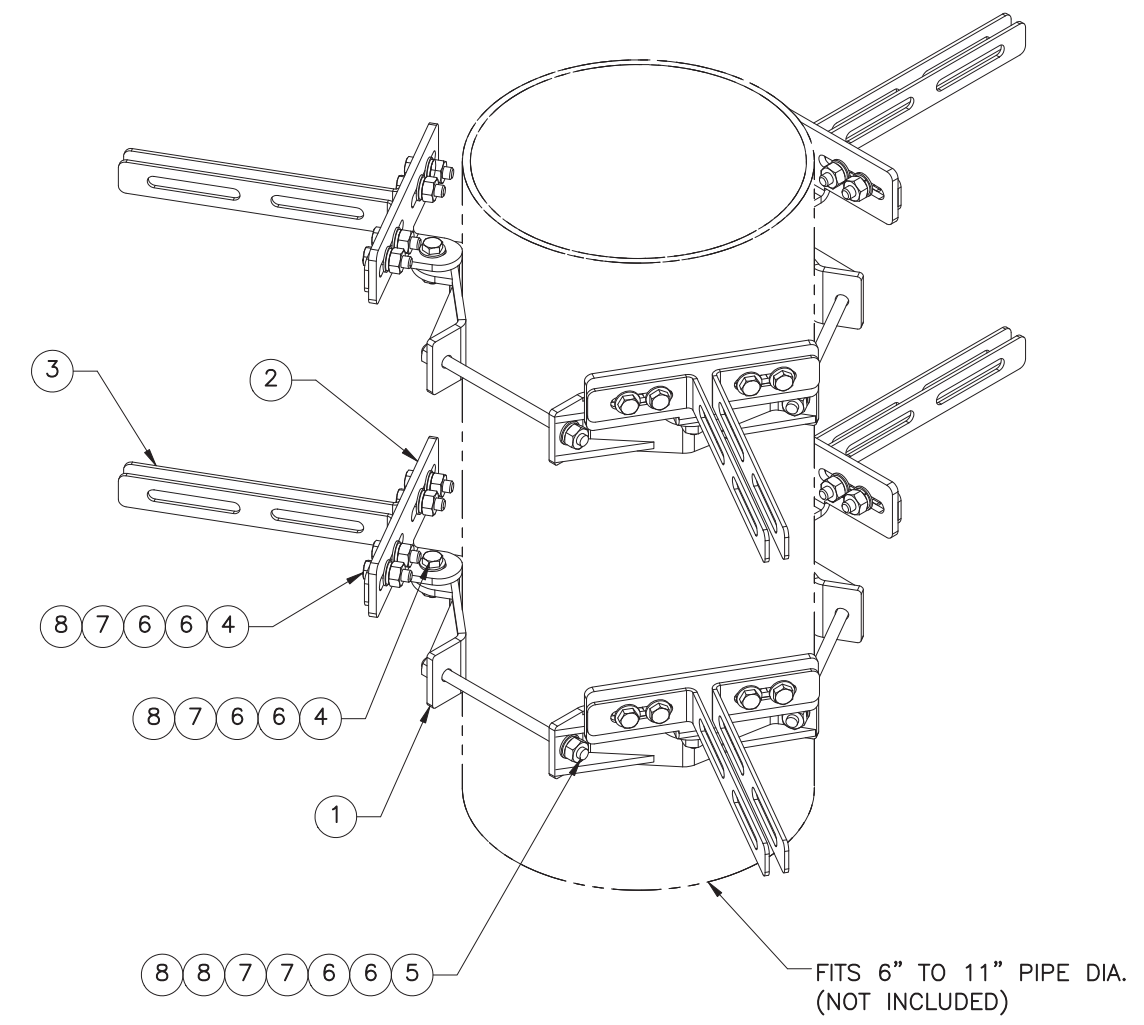

THE INFORMATION CONTAINED IN THIS DRAWING IS THE SOLE PROPERTY OF ELECTRO MECHANICAL INDUSTRIES, INC. ANY REPRODUCTION IN PART OR WHOLE WITHOUT THE WRITTEN PERMISSION OF ELECTRO MECHANICAL IND., IS PROHIBITED.

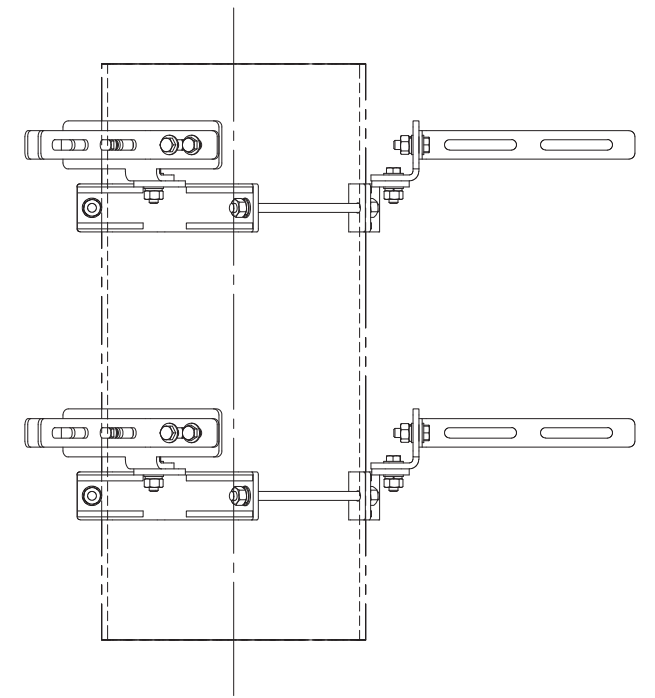
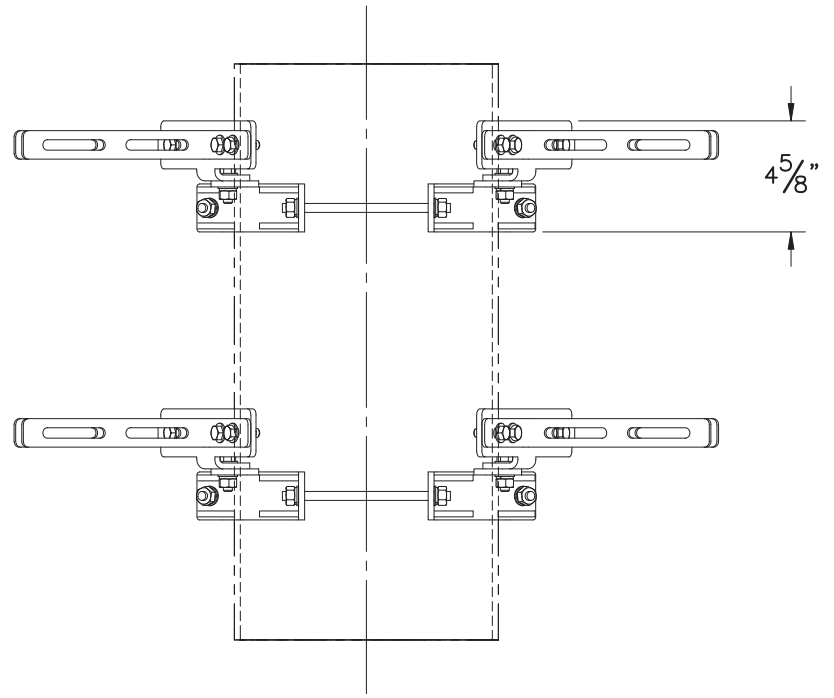
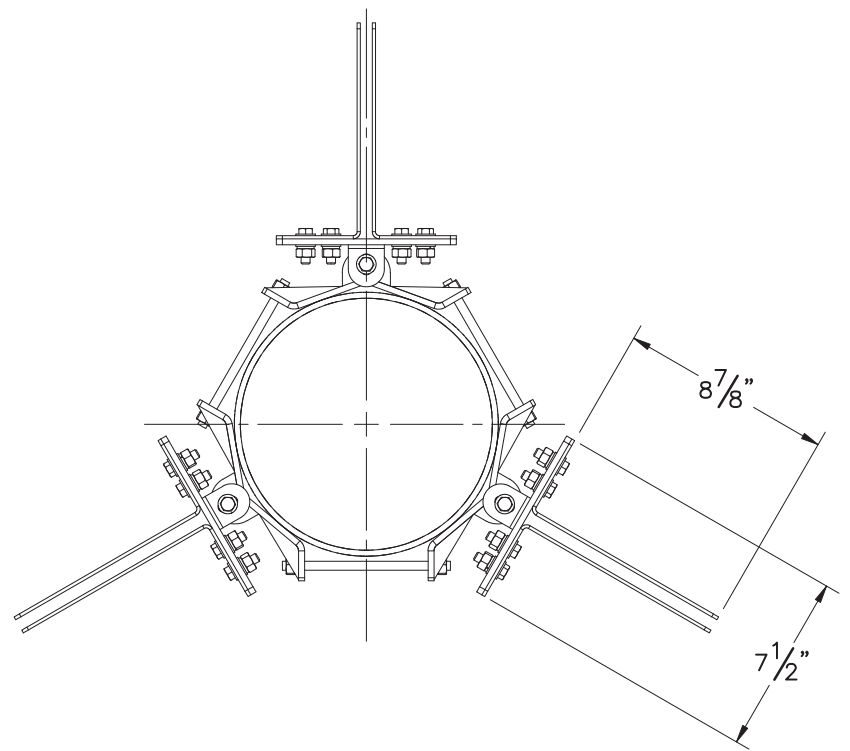

ITEM NO.	QTY REQD	PART NUMBER	DESCRIPTION	LENGTH	WEIGHT
1	6	W-002-679	TRIAD-FPL WELDMENT		1.76
2	6	P-007-148	7.5" ANTENNA BRACKET, TOP TRIAD - CAB	7 1/2"	1.07
3	12	P-007-170	TRIAD-CB BRACKET		0.42
4	30	002-0BG-0013	BOLT, HH, .375-16 X 1.25, GALV, GR 5, FT	1 1/4"	0.057
5	6	002-0AT-H055	AT, .375-16 X 7.0, GALV, GR B7	7"	0.22
6	72	002-0FW-G036	WASHER, FLAT, .375, GALV, SAE		0.01
7	42	002-0LW-G005	WASHER, SPLIT LOCK, .375, GALV		0.01
8	42	002-0NG-0003	NUT, HEX, .375-16, GALV, GR 2H		0.030

SURFACE FINISH <input checked="" type="checkbox"/> UNLESS OTHERWISE SPECIFIED		UNLESS OTHERWISE SPECIFIED DIMENSIONS ARE IN INCHES		APPROVALS	DATE	 ELECTRO MECHANICAL INDUSTRIES, INC. 11250 NEESHAW DRIVE HOUSTON, TEXAS 77065 1-800-453-0050
MATERIAL	SEE PARTS LIST	TOLERANCES		DRAWN	12/21/2023	
THIRD ANGLE PROJECTION		.0 ±.06 .00 ±.015 .000 ±.005		CHECKER	1/2/2024	<b>TRIAD FLUSH MOUNT 6" TO 11" DIA. POLE W/CB BRACKET</b>
		FRACTIONS ± 1/16 ANGLES ± .25°		ENGINEER	1/2/2024	
NEXT ASSY	USED ON	HOLES: DRILLED OR PUNCHED ± 1/32 BURNED ± 1/32		PRODUCTION	1/2/2024	
APPLICATIONS				J. KERNER		SIZE B DRAWING NO. 1012-0000-0128 REV 0 SCALE: 1:8 WEIGHT: 27.23 lbs. SHEET 1 OF 1