

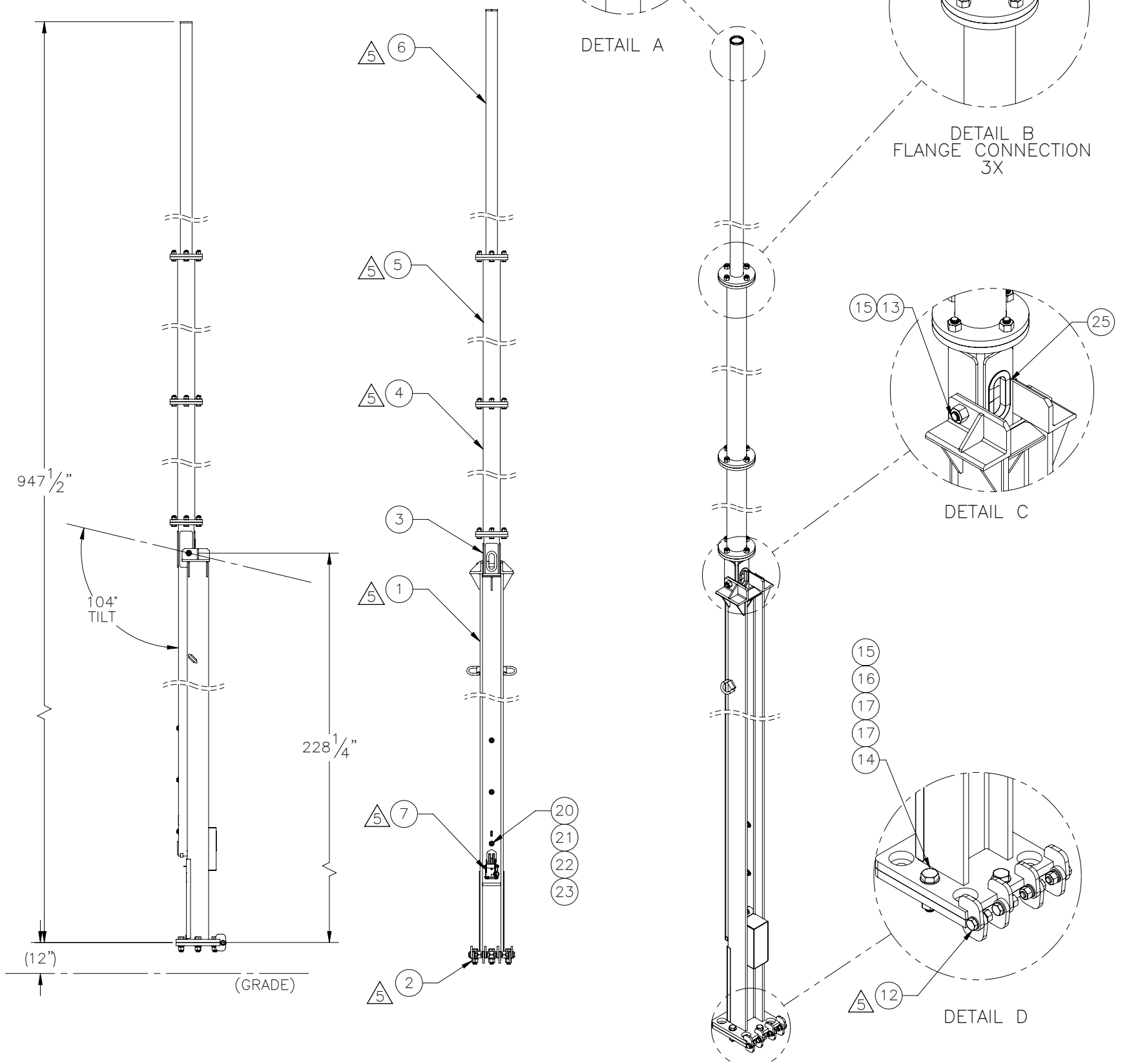

THE INFORMATION CONTAINED IN THIS DRAWING IS THE SOLE PROPERTY OF ELECTRO MECHANICAL INDUSTRIES, INC. ANY REPRODUCTION IN PART OR WHOLE WITHOUT THE WRITTEN PERMISSION OF ELECTRO MECHANICAL IND., IS PROHIBITED.

REVISIONS					
REV.	DCN #	DESCRIPTION	DATE	BY	APPROVED
5	01123	FIXED MATES DUE TO LOWER LEVEL CHANGES, .875 HINGE HW CHANGED TO KIT 1000-0020-0104	05/11/2022	JTR	JPB

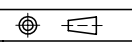

ITEM NO.	QTY REQD	PART NUMBER	DESCRIPTION	LENGTH	WEIGHT
5	1	A-000-007	SUPPORT BASE ASSEMBLY		1418.96
5	1	A-000-016	LOWER HINGE PLATE ASSEMBLY		104.05
3	1	A-000-008	LOWER SQUARE MAST ASSEMBLY		523.5
5	1	A-000-013	LOWER ROUND MAST ASSEMBLY		528.32
5	1	A-000-014	MIDDLE MAST ASSEMBLY		444.73
5	1	W-000-730	UPPER ROUND MAST ASSEMBLY		255.9
5	1	1002-0050-0014	WINCH KIT (1/4" X 56' WIRE ROPE)		1.9
8	1	400-004-3050-0612	WINCH COVER		8.717
9	1	400-004-5000-0071	.875 DIA. X 6.75 LG. PIN		1.13
10	1	400-004-5000-0072	.875 DIA. X 2.25 LG. PIN		0.36
11	1	400-004-5000-0080	4" SHEAVE ASSEMBLY		2.37
5	1	1000-0020-0104	TILT-UP TOWER QUAD HINGE .875" HARDWARE KIT		5.239
13	1	002-0BG-0035	BOLT, 1.25-7UNC X 10.00 LG, ASTM A325, GALV		4.15
14	4	002-0BG-0031	BOLT, HX HD, 1.25-7UNC X 5.00 LG, GR B7, GALV		2.38
15	5	002-0NG-0020	NUT, HX, ANCO LOCKNUT, 1.25-7UNC, GR 2H, GALV		0.79
16	4	002-0LW-G001	WASHER, SPLIT LOCK, 1.25, GALV.		0.174
17	8	002-0FW-G011	WASHER, FLAT, 1.25, ASTM F436, GALV		0.13
18	12	002-0BG-0279	BOLT, HX. HD., 1.00-8, ASTM A325, GALV.	3.50	1.12
19	12	002-0NG-0000	NUT, HX, ANCO LOCK, 1.00-8UNC, GR 2H, GALV		0.43
20	3	002-0BG-0247	BOLT, HX HD, .75"-10 X 9.50" LG., ASTM A325, GALV.		1.35
21	3	002-0NG-0002	NUT, HX, .75-10UNC, GR 2H, GALV		0.19
22	3	002-0LW-G003	WASHER, SPLIT LOCK, .75", GALV		0.04
23	6	002-0FW-G000	WASHER, FLAT, .75 INCH, USS, GALV		0.09
24	4	002-0OC-0002	COTTER PIN, .188 DIA. X 1.50 LG, GALV		0.007
25	1	309-000-0007-15	EDGE GUARD, 3/4", 15" LG	15"	0.236
26	1	309-000-0001-14	EDGE GUARD, 3/16", 14" LG	14"	0.1
27	1	400-004-5010-0135	FRONT COVER		8.23
28	2	999-999-L001	3.5" x 5" DO NOT CLIMB DECAL		0.006
29	2	999-999-L002	3.5" x 5" PINCH POINT DECAL		0.006
30	1	999-999-L003	3.5" x 5" WINCH RATING DECAL		0.006

SURFACE FINISH <input checked="" type="checkbox"/> UNLESS OTHERWISE SPECIFIED		UNLESS OTHERWISE SPECIFIED DIMENSIONS ARE IN INCHES		APPROVALS		DATE		 ELECTRO MECHANICAL INDUSTRIES, INC. 11230 NEESESHAW DRIVE HOUSTON, TEXAS 77065 1-800-453-0050	
MATERIAL SEE PARTS LIST		TOLERANCES		DRAWN C. SANCHEZ		11/20/2017		TITLE:	
THIRD ANGLE PROJECTION 		.0 ±.06 .00 ±.015 .000 ±.005 FRACTIONS ± 1/16 ANGLES ± .25°		CHECKER J. BUSHMAN		11/21/2017		80' TILT UP TOWER	
NEXT ASSY		HOLES: DRILLED OR PUNCHED		ENGINEER J. BUSHMAN		11/21/2017			
APPLICATIONS		BURNED ±1/32		PRODUCTION J. BOWLDS		11/21/2017		SIZE B	
								DRAWING NO. 400-004-5203	
								REV 5	
								SCALE: 1:48	
								WEIGHT: 3346.9 lbs.	
								SHEET 1 OF 1	