

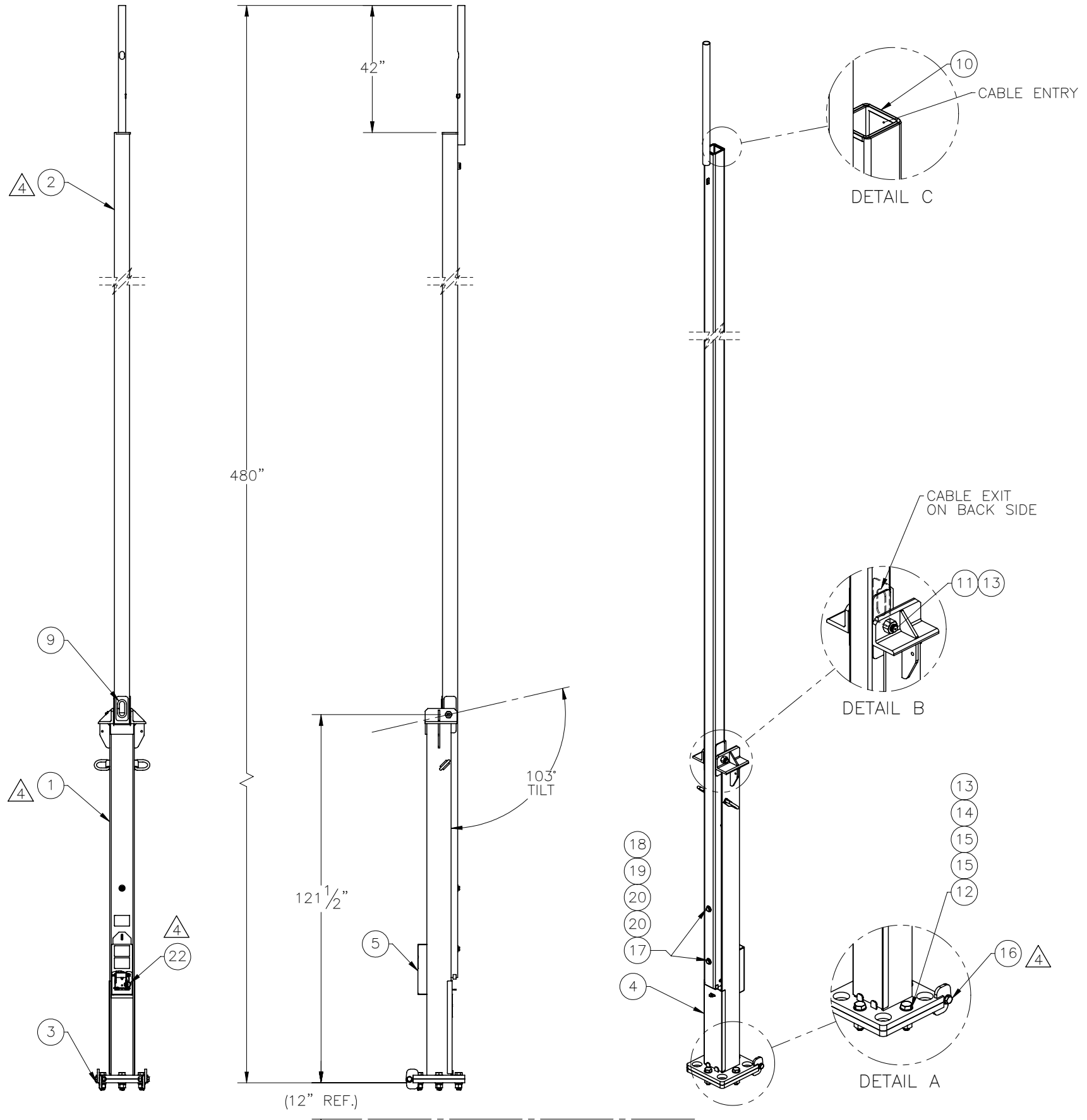

THE INFORMATION CONTAINED IN THIS DRAWING IS THE SOLE PROPERTY OF ELECTRO MECHANICAL INDUSTRIES, INC. ANY REPRODUCTION IN PART OR WHOLE WITHOUT THE WRITTEN PERMISSION OF ELECTRO MECHANICAL IND., IS PROHIBITED.

REVISIONS					
REV.	DCN #	DESCRIPTION	DATE	BY	APPROVED
4	01123	.875 HW REPLACED WITH KIT 1000-0020-0105, UPDATED WITH LOWER LEVEL CHANGES.	05/20/2022	JTR	JPB

130 MPH EIA/TIA REV G  
PATENT PENDING: #61322706

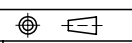

ITEM NO.	QTY	PART NUMBER	DESCRIPTION	LENGTH	WEIGHT
1	1	400-004-3044-0100	SUPPORT BASE ASSEMBLY		496.09
2	1	400-004-3044-0200	MAST ASSEMBLY		548.19
3	1	400-004-5000-0130	LOWER BASE PLATE ASSEMBLY		100.1
4	1	400-004-5000-0129	FRONT COVER		7.577
5	1	400-004-3050-0612	WINCH COVER		8.717
6	1	400-004-3054-0071	.875" DIA. X 5.75" LG. PIN		0.956
7	1	400-004-5000-0072	.875 DIA. X 2.25 LG. PIN		0.36
8	1	400-004-5000-0080	4" SHEAVE ASSEMBLY		2.37
9	1	309-000-0002-13	EDGE GUARD, 1/2", 13" LG.	13"	0.082
10	1	309-000-0001-18	EDGE GUARD, 3/16", 18" LG	18"	0.1
11	1	002-0BG-0032	BOLT, HX HD, 1.25-7UNC X 9.00 LG, A325, GALV		3.81
12	4	002-0BG-0031	BOLT, HX HD, 1.25-7UNC X 5.00 LG, GR B7, GALV		2.38
13	5	002-0NG-0020	NUT, HX, ANCO LOCKNUT, 1.25-7UNC, GR 2H, GALV		0.79
14	4	002-0LW-G001	WASHER, SPLIT LOCK, 1.25, GALV.		0.174
15	8	002-0FW-G011	WASHER, FLAT, 1.25, ASTM F436, GALV		0.13
16	1	1000-0020-0105	TILT-UP TOWER DUAL HINGE .875" HARDWARE KIT		2.619
17	2	002-0BG-0007	BOLT, HX HD, .75-10UNC X 8.00 LG, A325, GALV		1.16
18	2	002-0NG-0002	NUT, HX, .75-10UNC, GR 2H, GALV		0.19
19	2	002-0LW-G003	WASHER, SPLIT LOCK, .75", GALV		0.04
20	4	002-0FW-G000	WASHER, FLAT, .75 INCH, USS, GALV		0.09
21	4	002-00C-0002	COTTER PIN, 3/16" DIA. X 1-1/2" LG. , GALV.		0.007
22	1	1002-0050-0012	WINCH KIT (1/4" X 28' WIRE ROPE)		1.9
23	2	999-999-L001	3.5" x 5" DO NOT CLIMB DECAL		0.006
24	2	999-999-L002	3.5" x 5" PINCH POINT DECAL		0.006
25	1	999-999-L003	3.5" x 5" WINCH RATING DECAL		0.006

SURFACE FINISH <input checked="" type="checkbox"/> UNLESS OTHERWISE SPECIFIED		UNLESS OTHERWISE SPECIFIED DIMENSIONS ARE IN INCHES		APPROVALS		DATE		 ELECTRO MECHANICAL INDUSTRIES, INC. 11230 NEESESHAW DRIVE HOUSTON, TEXAS 77065 1-800-453-0050	
MATERIAL SEE PARTS LIST		TOLERANCES		DRAWN CS		10/25/2011			
THIRD ANGLE PROJECTION 		FRACTIONS ± 1/16		CHECKER LC		10/28/2011		TITLE: <h3>40' TILT UP TOWER</h3>	
NEXT ASSY		ANGLES ± .25°		ENGINEER VGD		10/31/2011			
USED ON		HOLES: DRILLED OR PUNCHED ± 1/32		PRODUCTION JKS		10/31/2011		SIZE B DRAWING NO. 400-004-3044 REV 4	
APPLICATIONS		BURNED ± 1/32		SCALE: 1:40		WEIGHT: 1191.26 lbs.		SHEET 1 OF 1	