

THE INFORMATION CONTAINED IN THIS DRAWING IS THE SOLE PROPERTY OF ELECTRO MECHANICAL INDUSTRIES, INC. ANY REPRODUCTION IN PART OR WHOLE WITHOUT THE WRITTEN PERMISSION OF ELECTRO MECHANICAL IND., IS PROHIBITED.

REVISIONS					
REV.	DCN #	DESCRIPTION	DATE	BY	APPROVED
1	DCN00869	UPDATED HARDWARE AND ADDED SAFETY DECALS	2020.06.25	BLH	JPB

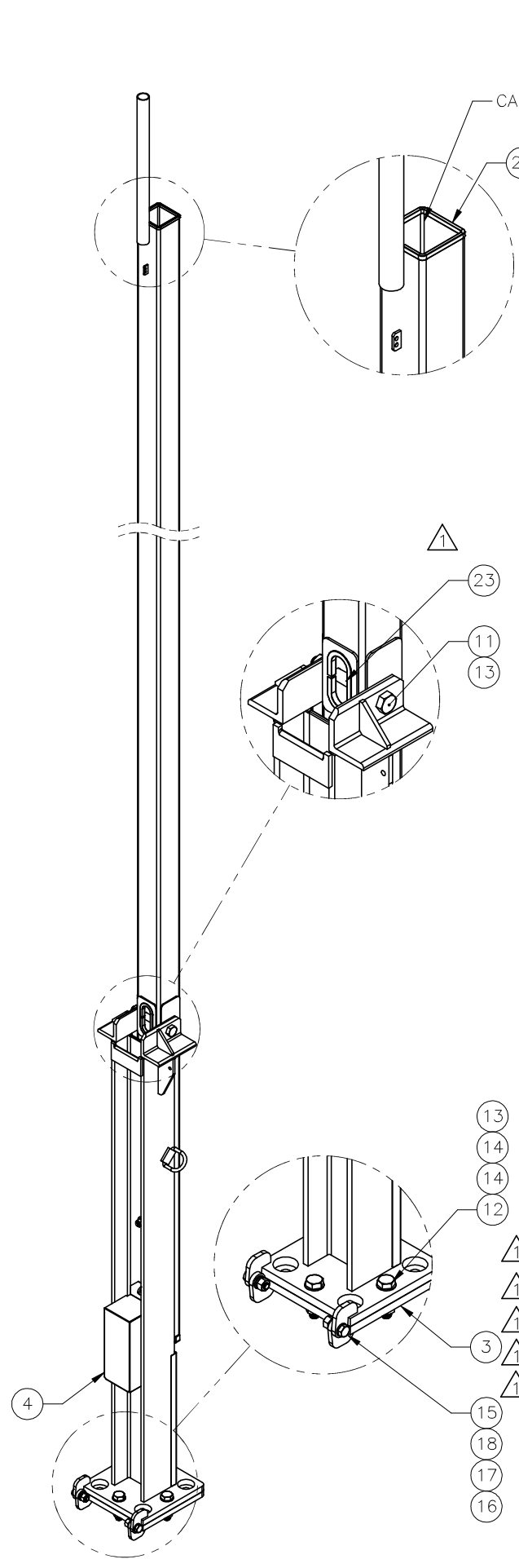
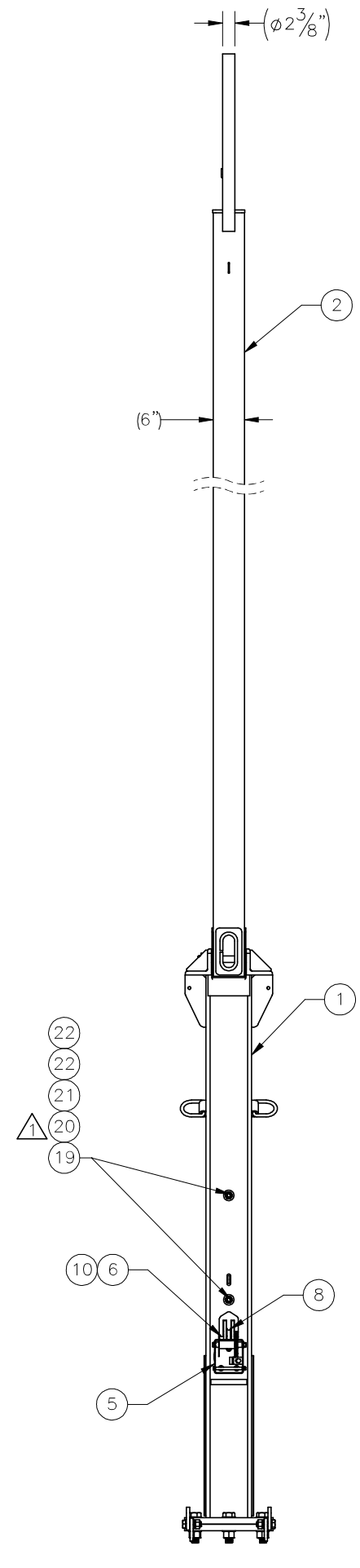
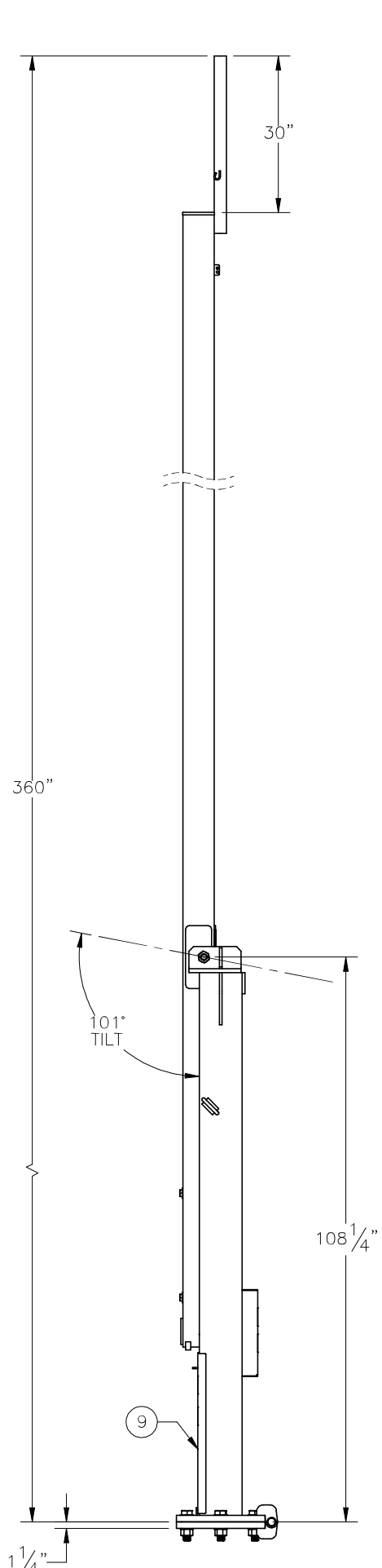

PATENT # 8,910,432

ITEM NO.	QTY REQD	PART NUMBER	DESCRIPTION	LENGTH	WEIGHT
1	1	W-001-005	SUPPORT BASE ASSEMBLY		660.5
2	1	W-001-006	MAST WELDMENT		494.7
3	1	400-004-5000-0130	LOWER BASE PLATE ASSEMBLY		100.1
4	1	400-004-3050-0612	WINCH COVER		8.740
5	1	1002-0050-0012	WINCH KIT (1/4" X 28' WIRE ROPE)		8.7
6	1	400-004-5000-0071	.875 DIA. X 6.75 LG. PIN		1.13
7	1	400-004-5000-0072	.875 DIA. X 2.25 LG. PIN		0.36
8	1	400-004-5000-0080	4" PULLEY ASSEMBLY		2.40
9	1	400-004-5010-0135	FRONT COVER		8.23
10	4	002-00C-0002	COTTER PIN, .187 X 1.50 LG, GALV		0.01
11	1	002-0BG-0035	BOLT, 1.25-7UNC X 10.00 LG, ASTM A325, GALV		4.15
12	4	002-0BG-0031	BOLT, HX HD, 1.25-7UNC X 5.00 LG, GR B7, GALV		2.38
13	5	002-0NG-0020	NUT, HX, ANCO LOCKNUT, 1.25-7UNC, GR 2H, GALV		0.79
14	8	002-0FW-G011	WASHER, FLAT, 1.25, ASTM F436, GALV		0.13
15	2	002-0BG-0040	BOLT, HX HD, .875-9UNC X 3.00 LG, ASTM A325, GALV		0.75
16	2	002-0NG-0009	NUT, HEX, .875-9UNC, GR 2H, GALV		0.29
17	2	002-0LW-G007	WASHER, SPLIT LOCK, .875, GALV		0.06
18	4	002-0FW-G008	WASHER, FLAT, .875, ASTM F436, GALV		0.09
19	2	002-0BG-0029	BOLT, HX HD, .75-10UNC X 9.00 LG, ASTM A325, GALV		1.29
20	2	002-0NG-0002	NUT, HX, .75-10UNC, GR 2H, GALV		0.19
21	2	002-0LW-G003	WASHER, SPLIT LOCK, .75", GALV		0.04
22	4	002-0FW-G000	WASHER, FLAT, .75 INCH, USS, GALV		0.09
23	1	309-000-0002-15	EDGE GUARD, 1/2", 15" LG,	15"	0.102
24	1	309-000-0001-21	EDGE GUARD, 3/16", 21" LG	21"	0.1
25	2	999-999-L001	3.5" x 5" DO NOT CLIMB DECAL		0.006
26	2	999-999-L002	3.5" x 5" PINCH POINT DECAL		0.006
27	1	999-999-L003	3.5" x 5" WINCH RATING DECAL		0.006

SURFACE FINISH <input checked="" type="checkbox"/> UNLESS OTHERWISE SPECIFIED		UNLESS OTHERWISE SPECIFIED DIMENSIONS ARE IN INCHES		APPROVALS		DATE	
MATERIAL SEE PARTS LIST		TOLERANCES		DRAWN C. SANCHEZ		8.9.18	
THIRD ANGLE PROJECTION		.0 ± .06		CHECKED J. BUSHMAN		8.9.18	
		.000 ± .005		ENGINEER/DESIGNER J. BUSHMAN		8.9.18	
		FRACTIONS ± 1/16		PRODUCTION J.K.S.		8.9.18	
		ANGLES ± .25°		SCALE: 1:30		WEIGHT: 1309.8 lbs.	
NEXT ASSY		DRILLED OR PUNCHED ± 1/32		BURNED ± 1/32		REV 1	
APPLICATIONS						SHEET 1 OF 1	



ELECTRO MECHANICAL INDUSTRIES, INC.
11230 NEESEHAW DRIVE
HOUSTON, TEXAS 77065
1-800-453-0050

30' TILT-UP TOWER (6" MAST)

SIZE **B** DRAWING NO. **400-004-2047**