

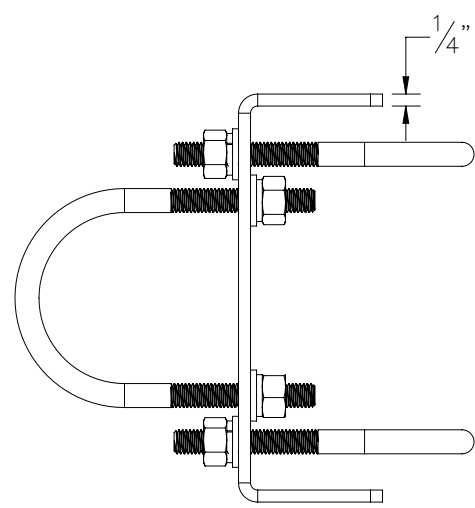

THE INFORMATION CONTAINED IN THIS DRAWING IS THE SOLE PROPERTY OF ELECTRO MECHANICAL INDUSTRIES, INC. ANY REPRODUCTION IN PART OR WHOLE WITHOUT THE WRITTEN PERMISSION OF ELECTRO MECHANICAL IND., IS PROHIBITED.

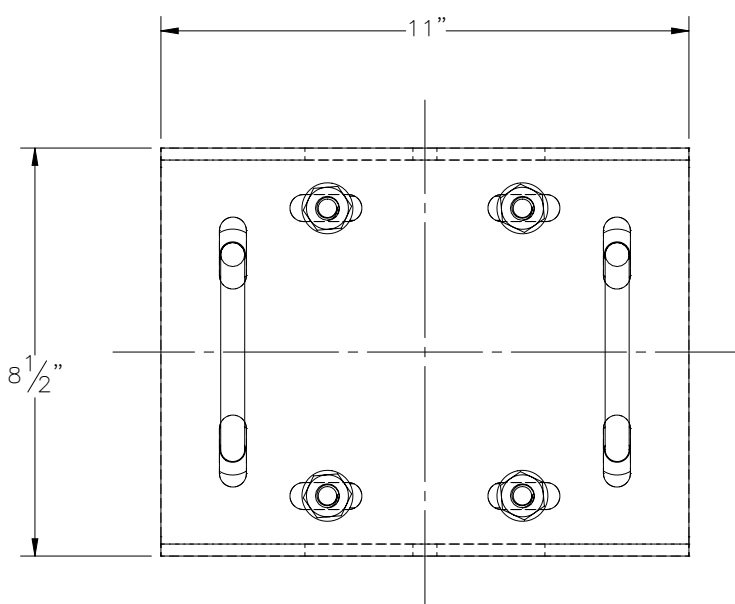
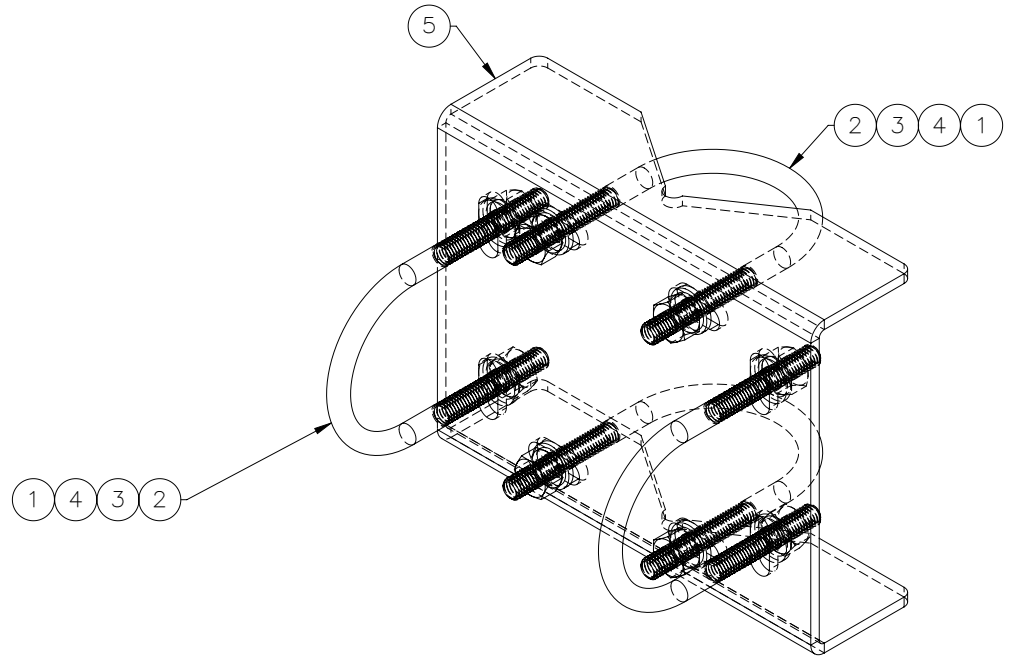
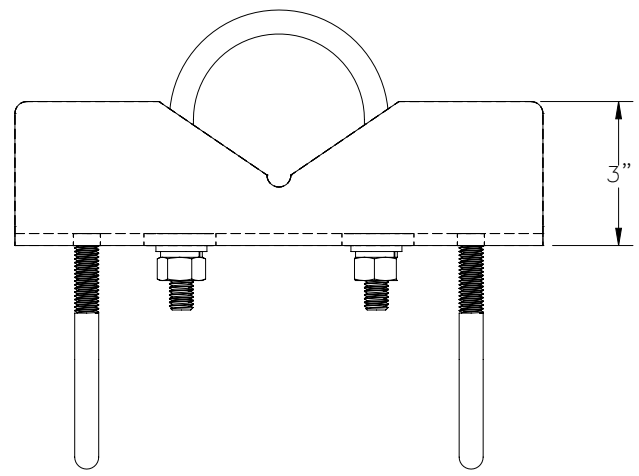
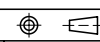

ITEM NO.	QTY REQ D	PART NUMBER	DESCRIPTION	LENGTH	WEIGHT
1	8	002-0NG-0010	NUT, HEX, .500-13UNC, GR 2H, GALV		0.06
2	4	002-00U-G043	U-BOLT, .500-13 X 3.50 I.D. X 5.75 HT, 3.0 THD, GALV.		0.74
3	8	002-0FW-G002	FW, .50, F436, HDG		0.02
4	8	002-0LW-G002	WASHER, SPLIT LOCK, .500", GALV		0.01
5	1	P-005-808	CROSSOVER PIPE MOUNT CLAMP		9.68

SURFACE FINISH <input checked="" type="checkbox"/> UNLESS OTHERWISE SPECIFIED		UNLESS OTHERWISE SPECIFIED DIMENSIONS ARE IN INCHES		APPROVALS		DATE		 ELECTRO MECHANICAL INDUSTRIES, INC. 11230 NEESESHAW DRIVE HOUSTON, TEXAS 77065 1-800-453-0050	
MATERIAL SEE PARTS LIST		TOLERANCES		DRAWN P. GUTIERREZ		6/28/2023			
THIRD ANGLE PROJECTION 		.0 ±.06 .00 ±.015 .000 ±.005		CHECKER B. HUTSON		06/28/2023		TITLE: CROSSOVER PIPE MOUNT CLAMP, 3.50 TO 3.50 OD PIPES - L3-XP-3030-HD	
NEXT ASSY		FRACTIONS ± 1/16		ENGINEER B. HUTSON		06/28/2023			
USED ON		ANGLES ± .25°		PRODUCTION B. HUTSON		06/28/2023			
APPLICATIONS		HOLES: DRILLED OR PUNCHED +1/32		SCALE: 1:4		WEIGHT: 13.43 lbs.		SHEET 1 OF 1	
		BURNED ±1/32		DRAWING NO. 1012-0000-0042		REV -			