

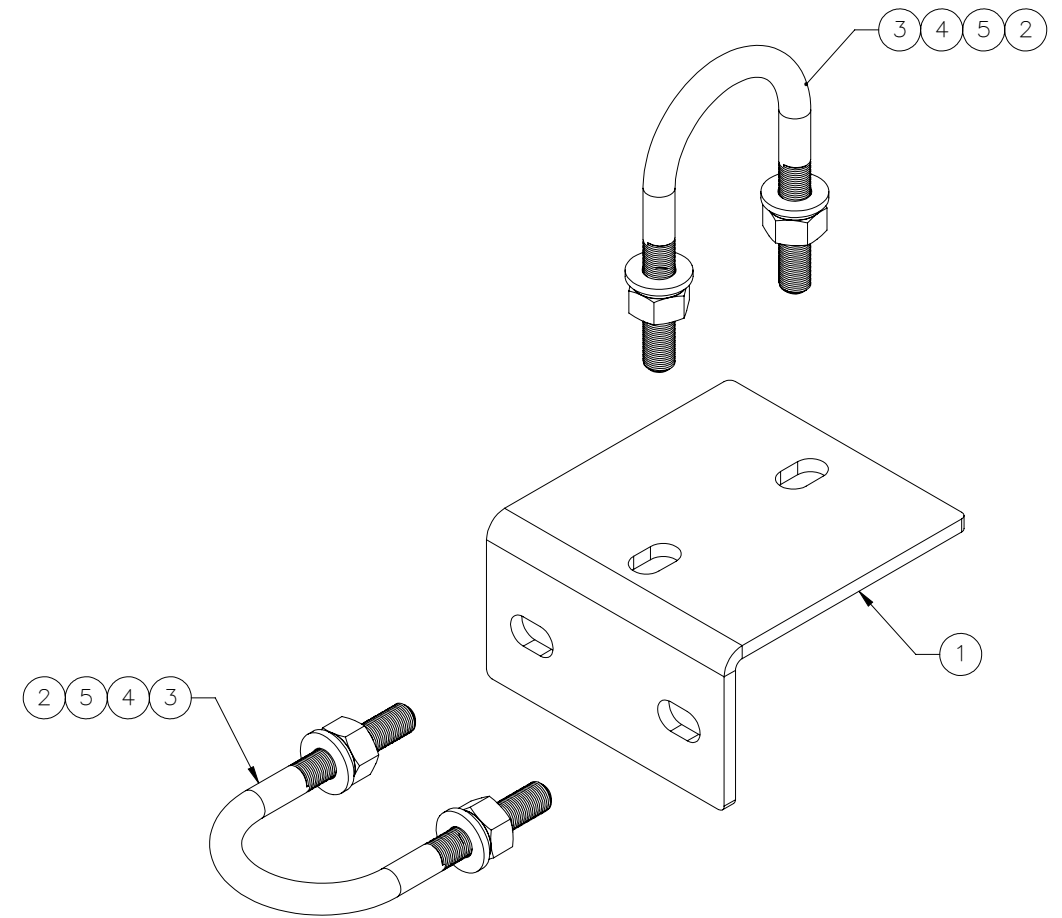

THE INFORMATION CONTAINED IN THIS DRAWING IS THE SOLE PROPERTY OF ELECTRO MECHANICAL INDUSTRIES, INC. ANY REPRODUCTION IN PART OR WHOLE WITHOUT THE WRITTEN PERMISSION OF ELECTRO MECHANICAL IND., IS PROHIBITED.

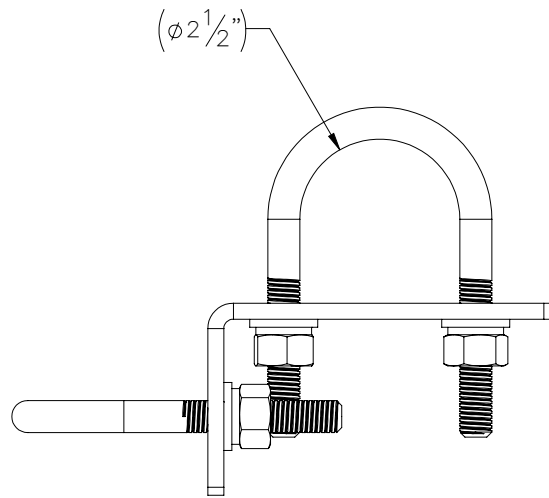
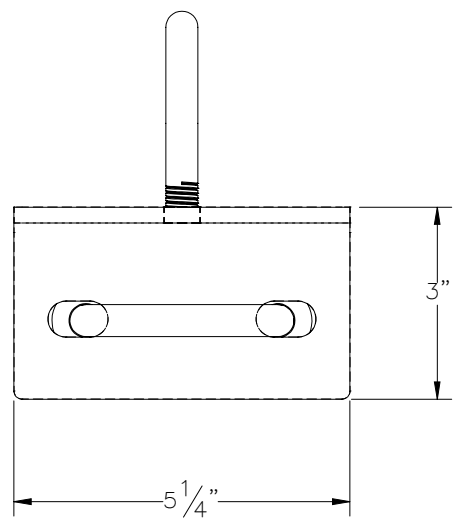
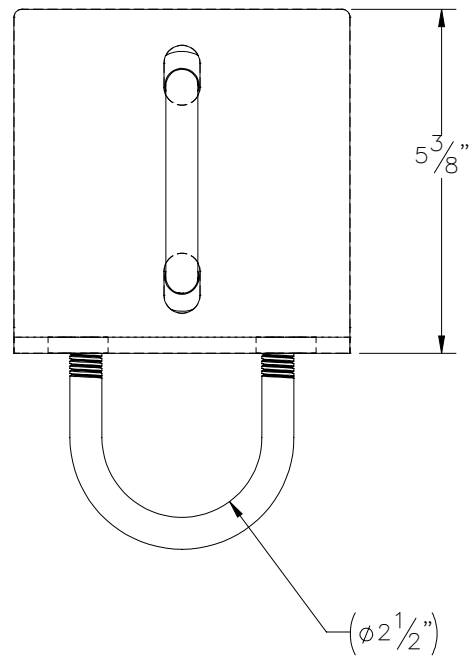
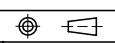

ITEM NO.	QTY	PART NUMBER	DESCRIPTION	LENGTH	WEIGHT
1	1	P-005-069	PIPE STANDOFF BRACKET		2.85
2	4	002-0NG-0010	NUT, HEX, .500-13UNC, GR 2H, GALV		0.06
3	2	002-00U-G045	U-BOLT, .500-13 X 2.44 I.D. X 4.63 HT, 2.5 THD, GALV		0.62
4	4	002-0FW-G002	FW, .50, F436, HDG		0.02
5	4	002-0LW-G002	WASHER, SPLIT LOCK, .500", GALV		0.01

SURFACE FINISH <input checked="" type="checkbox"/> UNLESS OTHERWISE SPECIFIED		UNLESS OTHERWISE SPECIFIED DIMENSIONS ARE IN INCHES		APPROVALS	DATE	 ELECTRO MECHANICAL INDUSTRIES, INC. 11230 NEESESHAW DRIVE HOUSTON, TEXAS 77065 1-800-453-0050
MATERIAL	SEE PARTS LIST	TOLERANCES		DRAWN	5/31/2023	
THIRD ANGLE PROJECTION		.0 ±.06 .00 ±.015 .000 ±.005		CHECKER		TITLE: PIPE CROSSOVER ANGLE, 2.375 OD X 2.375 OD - L3-XA-2020
NEXT ASSY	USED ON	FRACTIONS ± 1/16 ANGLES ± .25° HOLES: DRILLED OR PUNCHED ± 1/32 BURNED ± 1/32		ENGINEER		
APPLICATIONS				PRODUCTION		SIZE B DRAWING NO. 1012-0000-0037 REV - SCALE: 1:3 WEIGHT: 4.50 lbs. SHEET 1 OF 1