

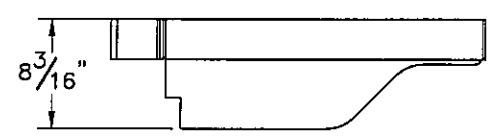

THE INFORMATION CONTAINED IN THIS DRAWING IS THE SOLE PROPERTY OF ELECTRO MECHANICAL INDUSTRIES, INC. ANY REPRODUCTION IN PART OR WHOLE WITHOUT THE WRITTEN PERMISSION OF ELECTRO MECHANICAL IND., IS PROHIBITED.

REVISIONS					
REV.	DCN #	DESCRIPTION	DATE	BY	APPROVED
2	DCN00357	UPDATED PART #'S	11.30.17	JGC	<i>[Signature]</i>

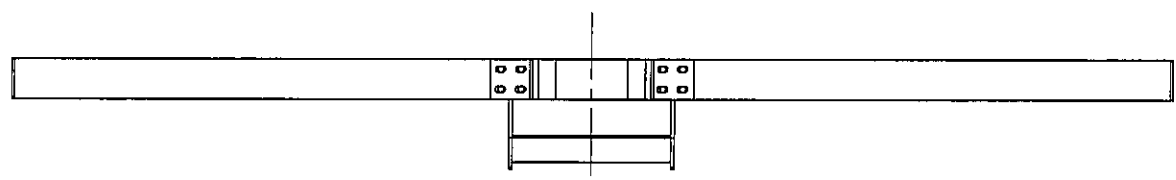
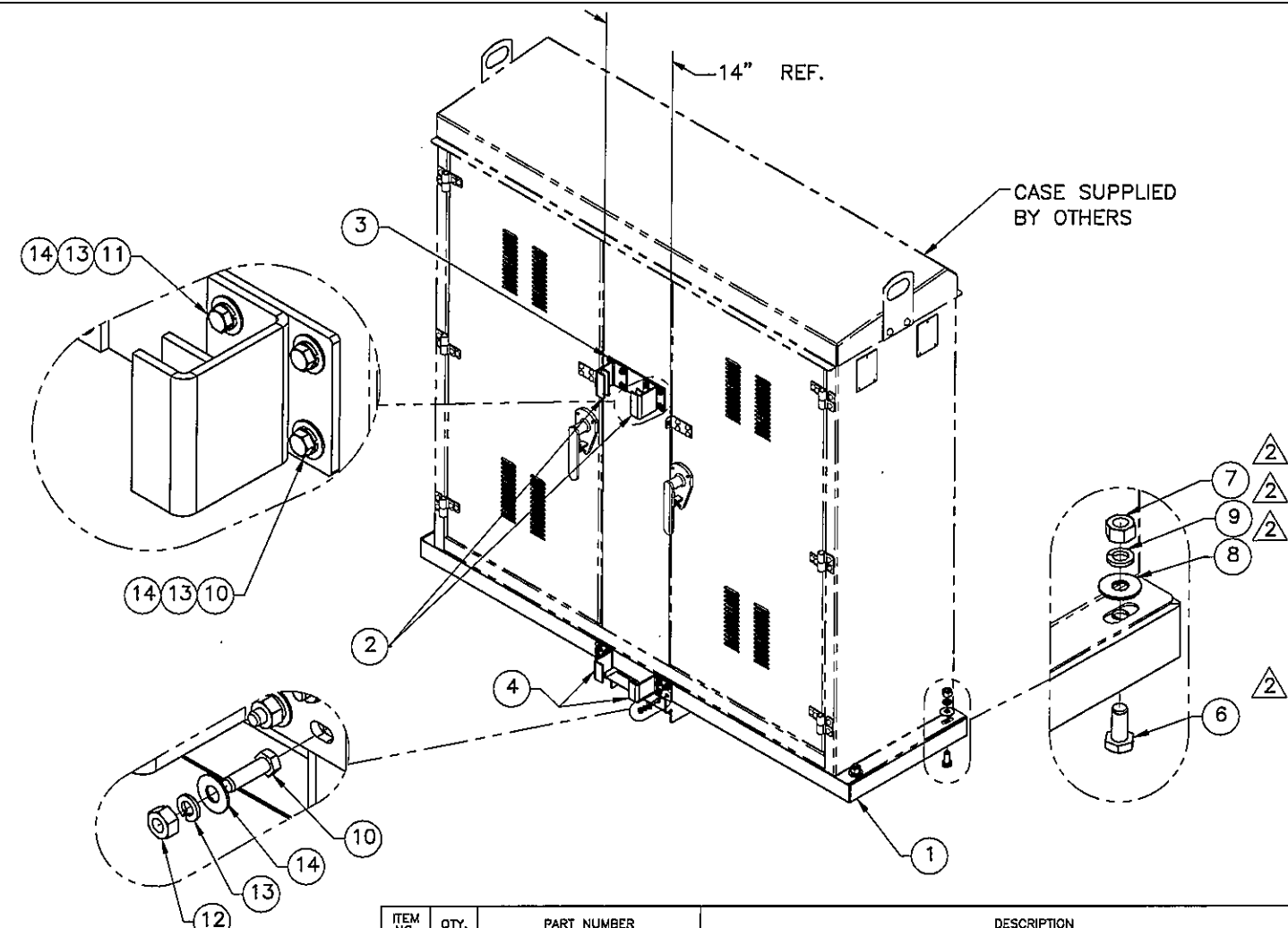
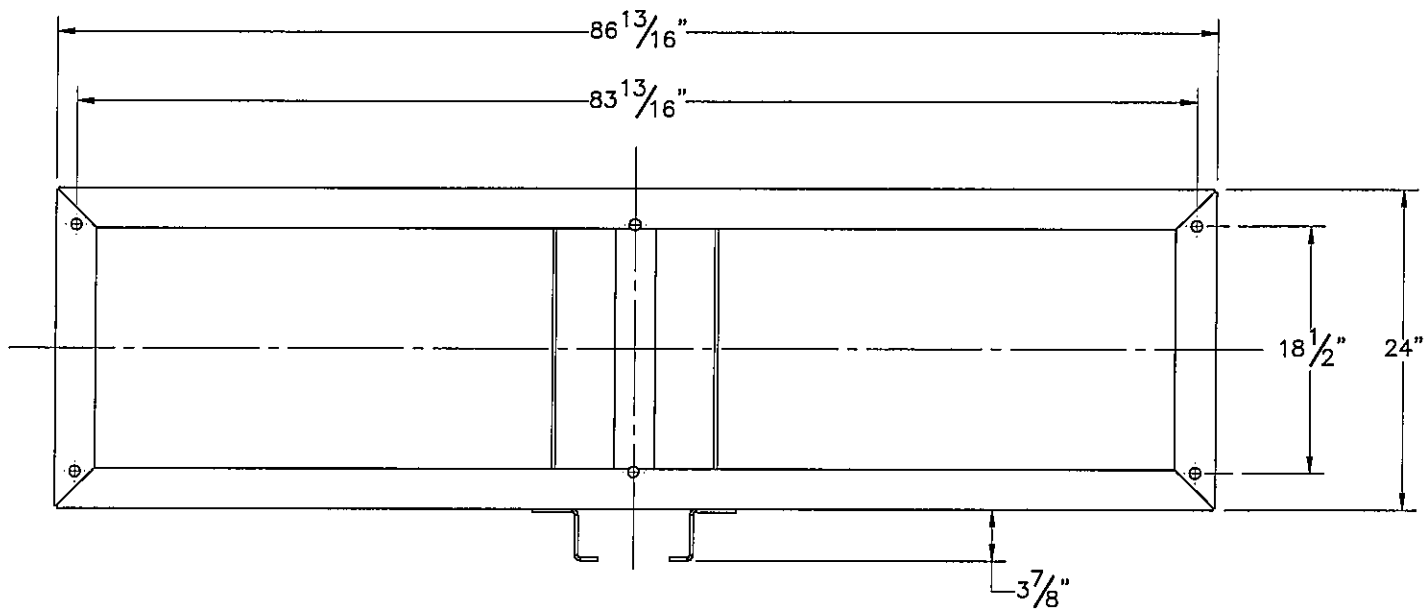

ITEM NO.	QTY.	PART NUMBER	DESCRIPTION	WEIGHT
1	1	W-000-571	TOWER SIDE PLATFORM WELDMENT FRAME	96
2	2	W-000-574	UPPER BEAM CLAMP	2.51
3	1	P-001-496	BACKING PLATE	3.18
4	2	400-904-1002-0106	BOTTOM BEAM CLAMP	1.69
5	1	400-004-3054-0129	FRONT COVER	
6	6	002-0BG-0207	BOLT, HEX, .750"-10 X 1.75" LG., FULLY THREAD, A325, GALV.	0.40
7	6	002-0NG-0019	NUT, HEX, .750"-10, GR DH, GALV.	0.19
8	6	002-0FW-G000	WASHER, FLAT, .750", GALV.	0.10
9	6	002-0LW-G003	WASHER, SPLIT-LOCK, .750", GALV.	0.05
10	12	002-0BG-0013	BOLT, HX HD, .375-16UNC X 1.25 LG, GR 5, GALV	0.06
11	4	002-0BG-0008	BOLT, HX HD, .375-16UNC X 1.50 LG, GR 5, GALV	0.06
12	8	002-0NG-0003	NUT, HEX, .375-16UNC, GR 2H, GALV	0.03
13	16	002-0LW-G005	WASHER, SPLIT LOCK, .375 INCH, GALV	0.01
14	16	002-0FW-G024	FLAT WASHER, 3/8" X 1" O.D. USS, GALV.	

SURFACE FINISH <input checked="" type="checkbox"/> UNLESS OTHERWISE SPECIFIED		UNLESS OTHERWISE SPECIFIED DIMENSIONS ARE IN INCHES		APPROVALS		DATE	 ELECTRO MECHANICAL INDUSTRIES, INC. 11230 NEESHAW DRIVE HOUSTON, TEXAS 77065 1-800-453-0050
MATERIAL SEE PARTS LIST		TOLERANCES		DRAWN P. GUTIERREZ		7.3.17	
THIRD ANGLE PROJECTION		FRACTIONS ± 1/16		CHECKED C. SANCHEZ		07.27.2017	TOWER SIDE ACCESSORY PLATFORM W/ BRACKETS
NEXT ASSY USED ON		ANGLES ± .25°		ENGINEER/DESIGNER J. BUSHMAN		08.01.2017	
APPLICATIONS		HOLES: DRILLED OR PUNCHED ± 1/32		PRODUCTION J. BOWLDS		08.01.2017	
		BURNED ± 1/32		SCALE: 1:14		WEIGHT: 114 lbs.	SHEET 1 OF 2

8

7

6

5

4

3

2

1

D

C

B

A

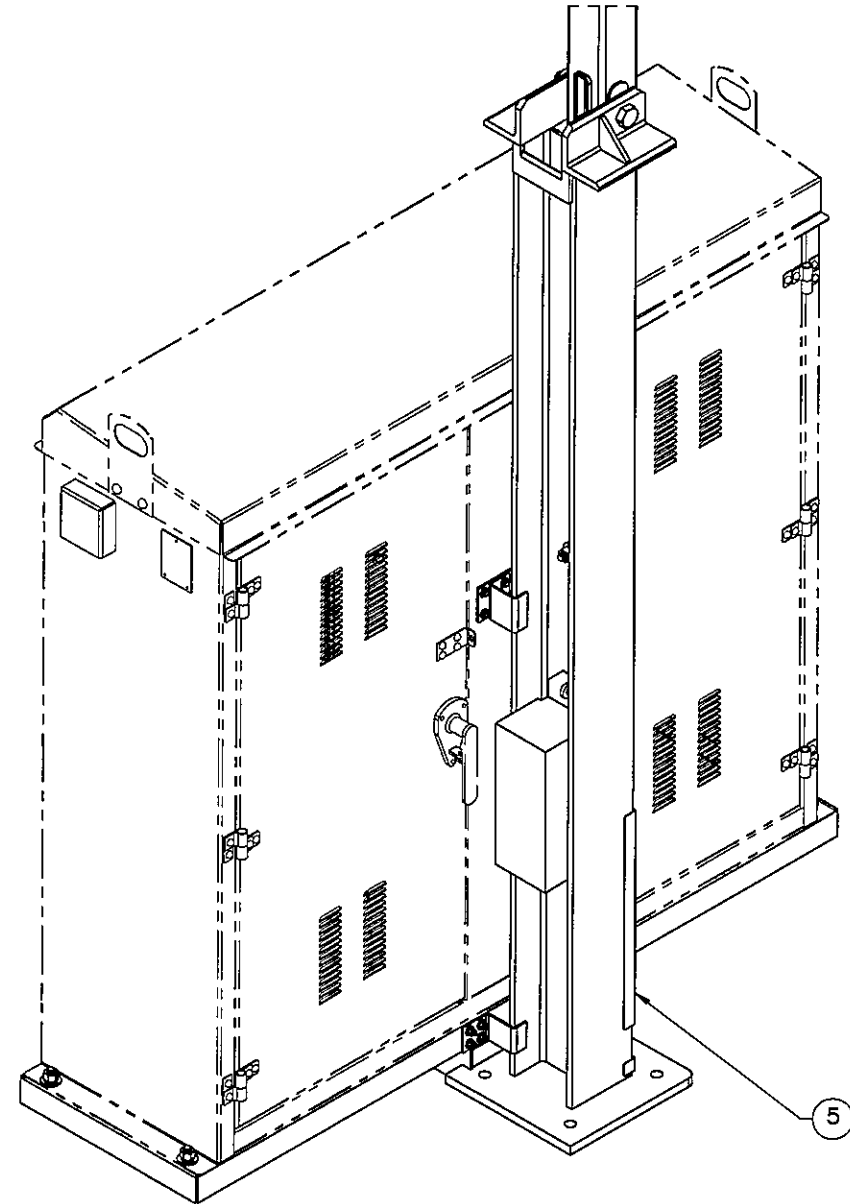
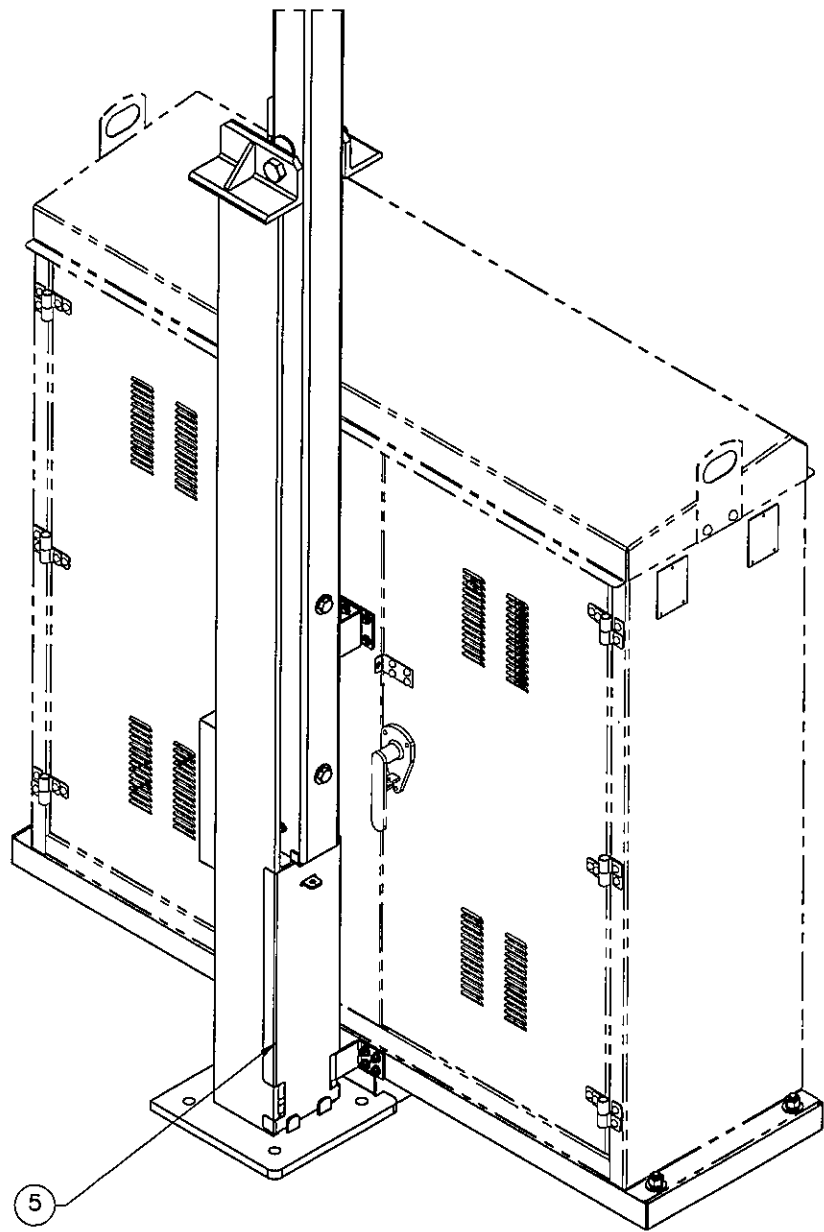

D

C

B

A

8

7

6

5

4

3

2

1

		ELECTRO MECHANICAL INDUSTRIES, INC. 11230 NEESEAW DRIVE HOUSTON, TEXAS 77065 1-800-453-0330	
SIZE	DRAWING NO.	REV	
B	1002-0050-0011	2	
SCALE: 1:18		SHEET 2 OF 2	