

THE INFORMATION CONTAINED IN THIS DRAWING IS THE SOLE PROPERTY OF ELECTRO MECHANICAL INDUSTRIES, INC. ANY REPRODUCTION IN PART OR WHOLE WITHOUT THE WRITTEN PERMISSION OF ELECTRO MECHANICAL IND., IS PROHIBITED.

REVISIONS					
REV.	DCN #	DESCRIPTION	DATE	BY	APPROVED
4	01092	002-0BG-0026 TO 002-0BG-0010, 450-000-0180-0265 TO W-002-288, 450-000-0180-0266 TO W-002-289, NUT DESC TO 2H, 450-000-0100-0015 TO P-005-240, 450-000-0100-0011 TO P-005-241, W-001-864 REVISED FOR LOWER LEVEL CHANGES, DIM'S ADDED FOR CONSISTANCY/CLARITY	04/06/2022	JTR	JPB

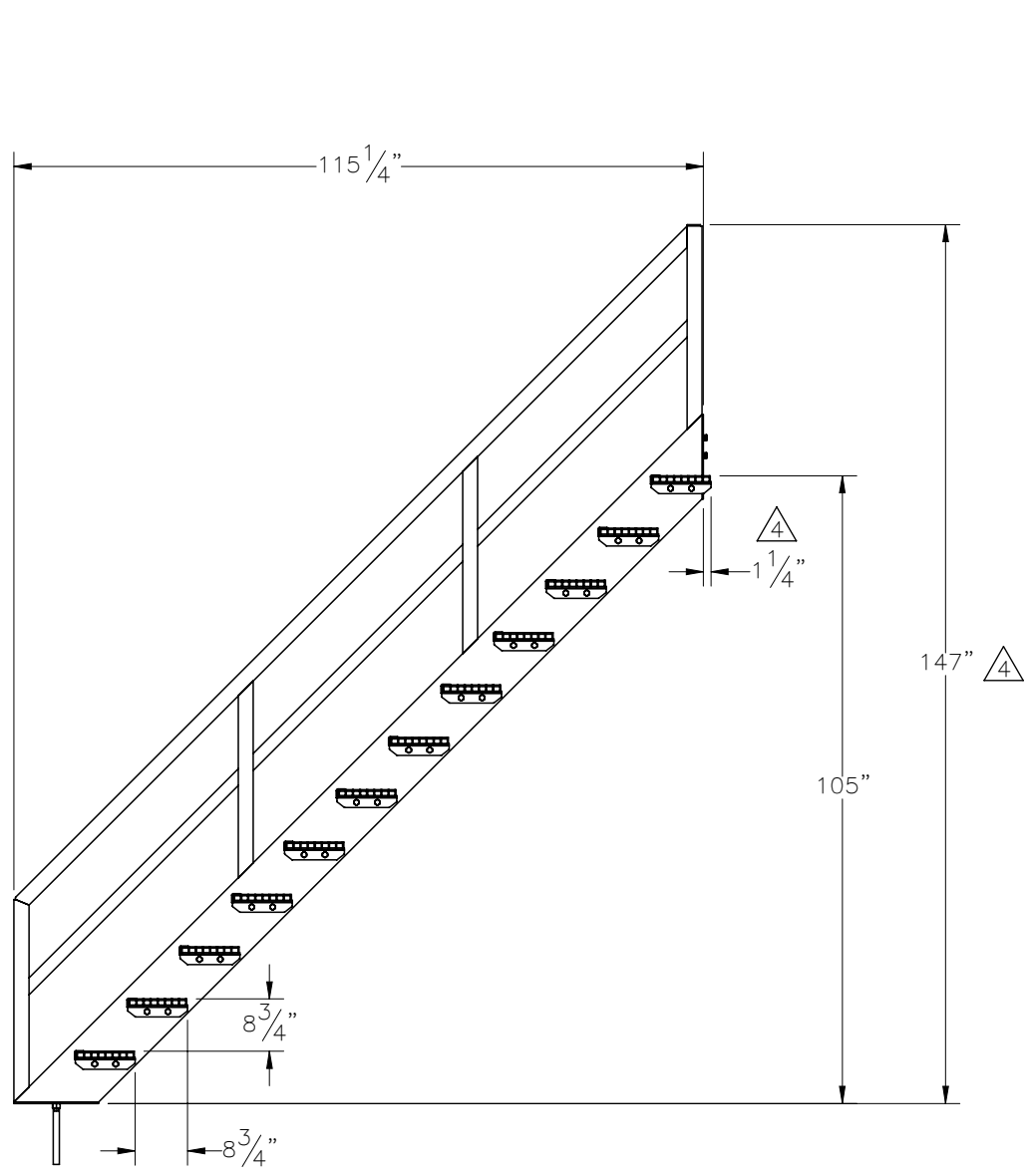

SECTION A-A

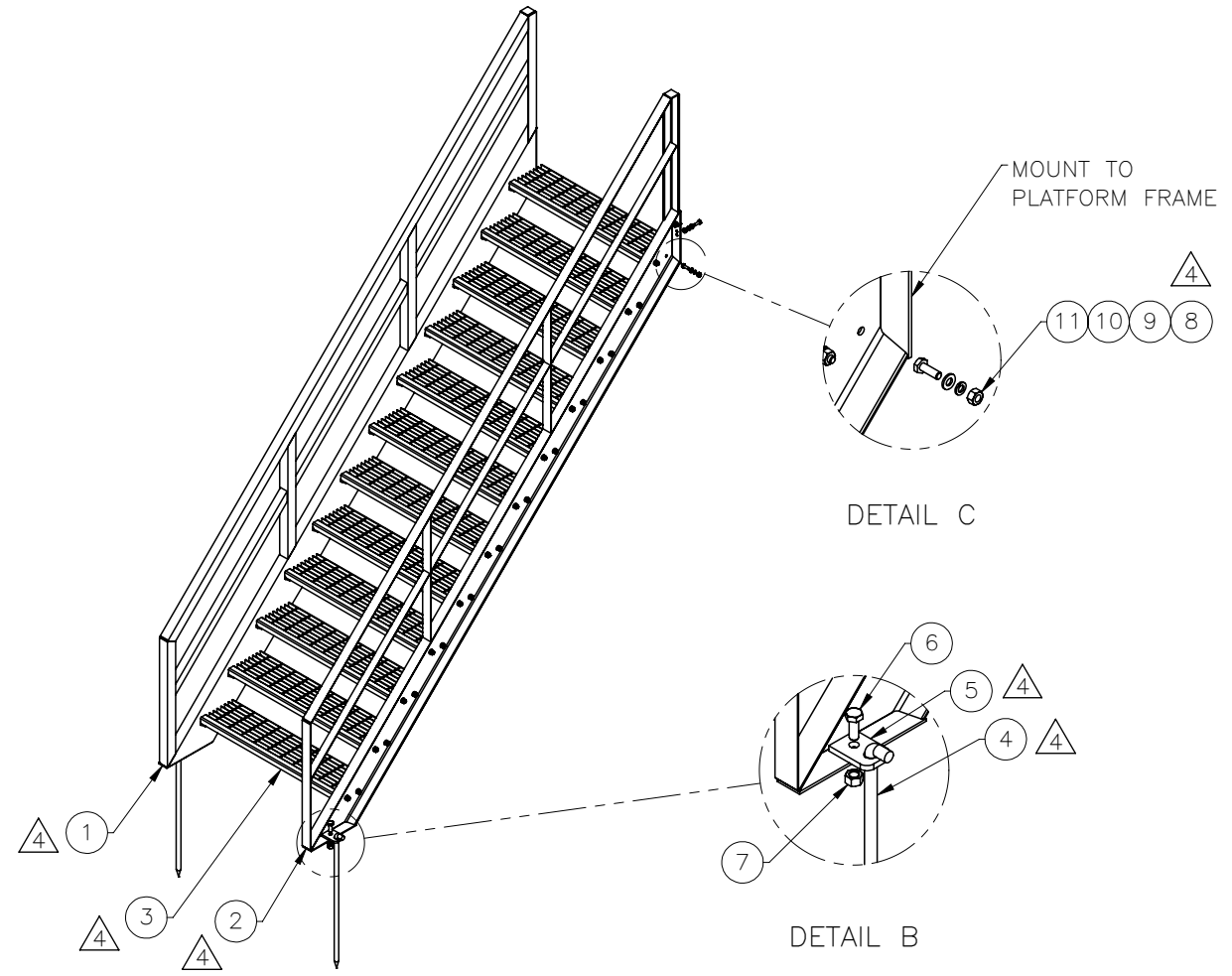
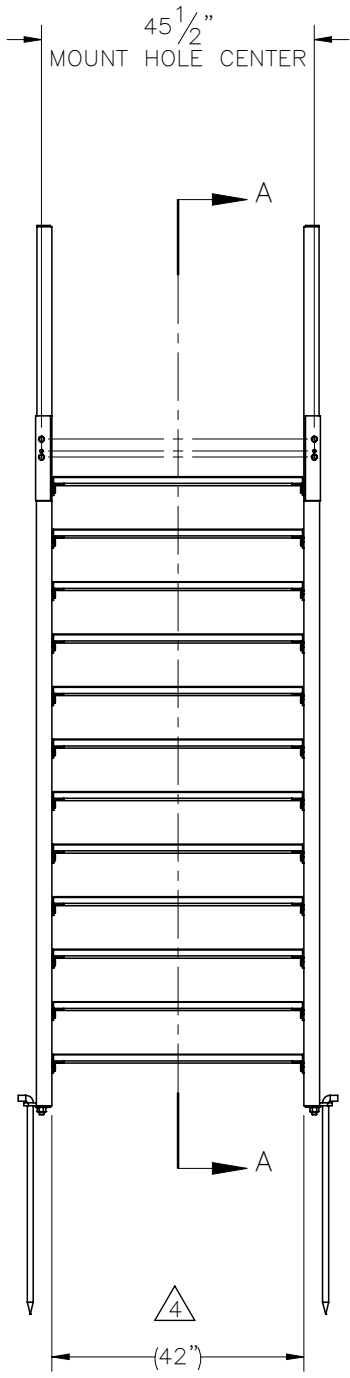

ITEM NO.	QTY	PART NUMBER	DESCRIPTION	LENGTH	WEIGHT
4 1	1	W-002-288	LEFT SIDE STAIR WELDMNT		336.7
4 2	1	W-002-289	RIGHT SIDE STAIR WELDMNT		336.7
4 3	12	W-001-864	42" WD, STAIR TREAD WELDMNT		29.82
4 4	2	P-005-241	1" STABILIZER ROD	36"	8.0948
4 5	2	P-005-240	ANCHOR PLATE, STAIR CASE	4 1/4"	1.6
6	2	002-0BG-0019	BOLT HX HD, .750-10UNC X 2.0 LG, A325, GALV	2"	0.43
7	2	002-0NG-0016	NUT, HX, ANCO LOCKNUT, .75-10UNC, GR 2H, GALV		0.19
4 8	52	002-0BG-0010	HHB, .500-13 X 1.50 LG., PT X 1.00, A325, HDG	1.50	0.14
9	52	002-0FW-G002	FW, .50, F436, HDG		0.02
10	52	002-0LW-G002	WASHER, SPLIT LOCK, .500", GALV		0.01
11	52	002-0NG-0010	NUT, HEX, .500-13UNC, GR 2H, GALV		0.06

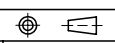
SURFACE FINISH <input checked="" type="checkbox"/> UNLESS OTHERWISE SPECIFIED		UNLESS OTHERWISE SPECIFIED DIMENSIONS ARE IN INCHES		APPROVALS		DATE		 ELECTRO MECHANICAL INDUSTRIES, INC. 11230 NEESESHAW DRIVE HOUSTON, TEXAS 77065 1-800-453-0050	
MATERIAL SEE PARTS LIST		TOLERANCES		DRAWN CS		5/3/2011			
THIRD ANGLE PROJECTION 		.0 ±.06		CHECKER VGD		9/21/2011		TITLE: 12 TREAD STAIR ASSY (42" WIDE)	
NEXT ASSY USED ON		.000 ±.005		ENGINEER VGD		9/21/2011			
APPLICATIONS		FRACTIONS ± 1/16		PRODUCTION JKS		9/22/2011		SIZE B DRAWING NO. 450-000-0183 REV 4	
		ANGLES ± .25°		SCALE: 1:32		WEIGHT: 1064.5 lbs.		SHEET 1 OF 1	
		HOLES: DRILLED OR PUNCHED ± 1/32							
		BURNED ± 1/32							