

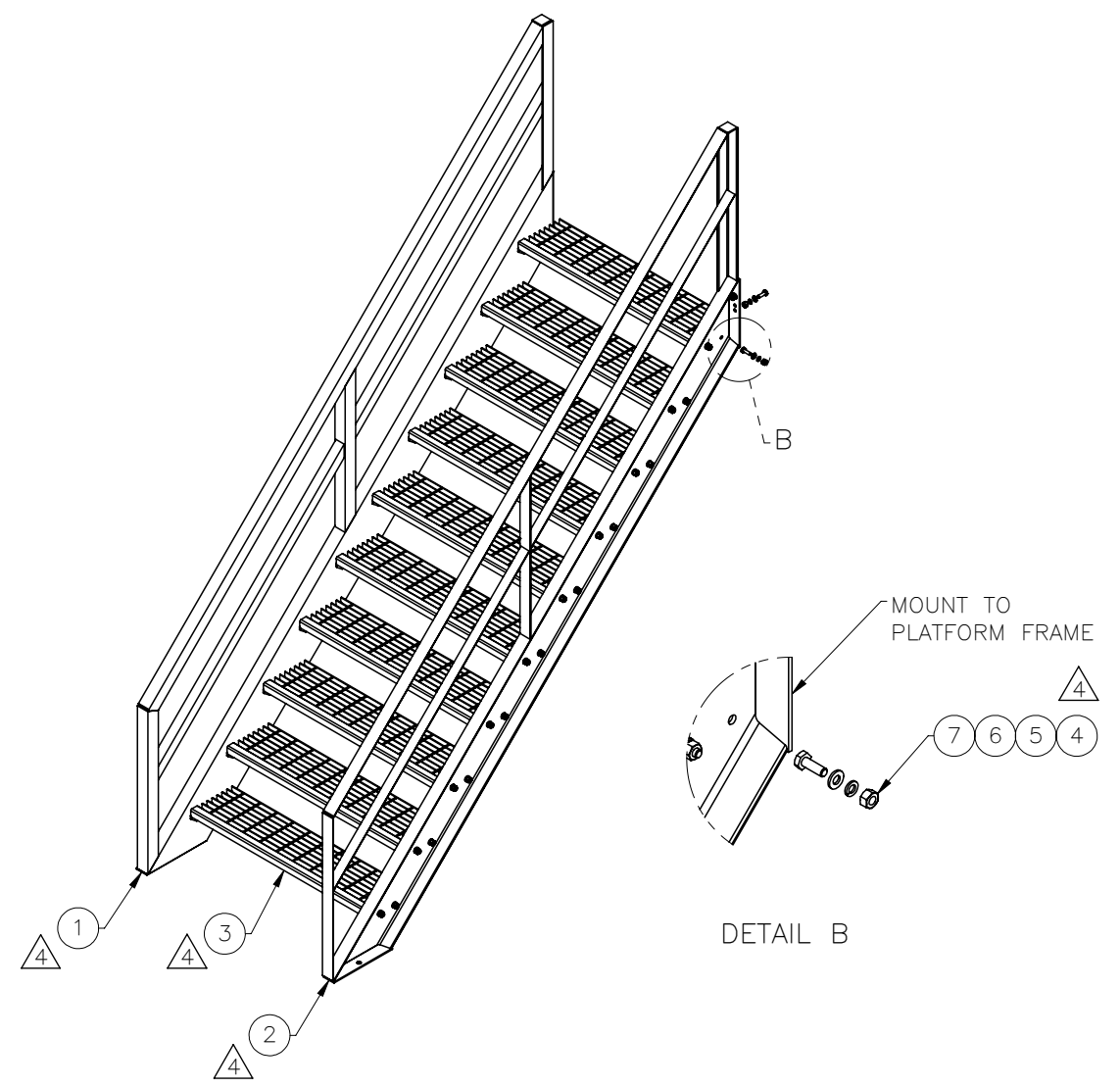

THE INFORMATION CONTAINED IN THIS DRAWING IS THE SOLE PROPERTY OF ELECTRO MECHANICAL INDUSTRIES, INC. ANY REPRODUCTION IN PART OR WHOLE WITHOUT THE WRITTEN PERMISSION OF ELECTRO MECHANICAL IND., IS PROHIBITED.

REVISIONS					
REV.	DCN #	DESCRIPTION	DATE	BY	APPROVED
4	01092	002-0BG-0026 TO 002-0BG-0010, 450-000-0170-0265 TO W-002-285, 450-000-0170-0266 TO W-002-286, W-001-864 UPDATED DUE TO LOWER LEVEL CHANGES, NUT DESC TO 2H, DIM'S ADDED FOR CONSISTENCY/CLARITY	04/06/2022	JTR	JPB

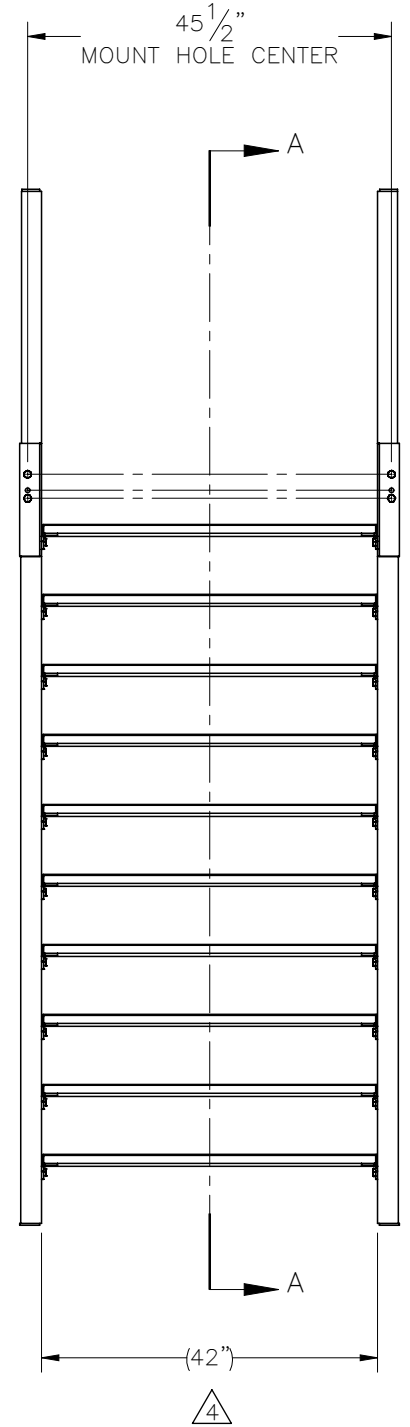
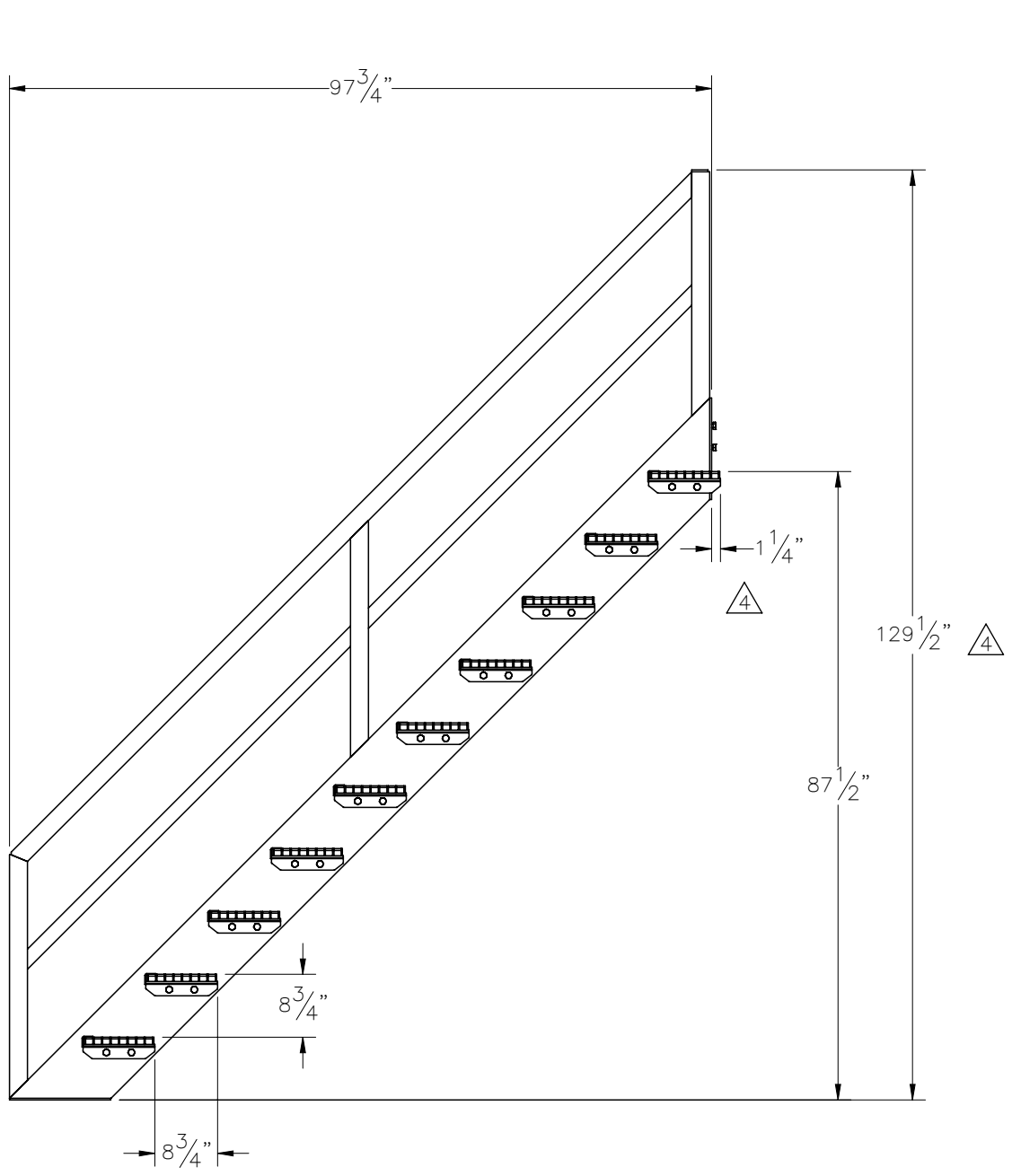

ITEM NO.	QTY	PART NUMBER	DESCRIPTION	LENGTH	WEIGHT
1	1	W-002-285	LEFT SIDE STAIR WELDMENT		280.2
2	1	W-002-286	RIGHT SIDE STAIR WELDMENT		280.2
3	10	W-001-864	42" WD, STAIR TREAD WELDMENT		29.82
4	44	002-0BG-0010	HHB, .500-13 X 1.50 LG., PT X 1.00, A325, HDG	1.50	0.14
5	44	002-0FW-G002	FW, .50, F436, HDG		0.02
6	44	002-0LW-G002	WASHER, SPLIT LOCK, .500", GALV		0.01
7	44	002-0NG-0010	NUT, HEX, .500-13UNC, GR 2H, GALV		0.06

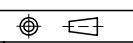
SURFACE FINISH <input checked="" type="checkbox"/> UNLESS OTHERWISE SPECIFIED		UNLESS OTHERWISE SPECIFIED DIMENSIONS ARE IN INCHES		APPROVALS		DATE		 ELECTRO MECHANICAL INDUSTRIES, INC. 11230 NEESESHAW DRIVE HOUSTON, TEXAS 77065 1-800-453-0050	
MATERIAL SEE PARTS LIST		TOLERANCES		DRAWN RLWjr		8/13/2012			
THIRD ANGLE PROJECTION 		FRACTIONS ± 1/16		CHECKER CS		8/13/2012		TITLE: 10 TREAD STAIR ASSY (42" WIDE)	
NEXT ASSY USED ON		ANGLES ± .25°		ENGINEER CS		8/13/2012			
APPLICATIONS		HOLES: DRILLED OR PUNCHED ± 1/32		PRODUCTION JKS		8/14/2012		SIZE B DRAWING NO. 450-000-0173 REV 4	
		BURNED ± 1/32						SCALE: 1:24 WEIGHT: 869.25 lbs. SHEET 1 OF 1	