

THE INFORMATION CONTAINED IN THIS DRAWING IS THE SOLE PROPERTY OF ELECTRO MECHANICAL INDUSTRIES, INC. ANY REPRODUCTION IN PART OR WHOLE WITHOUT THE WRITTEN PERMISSION OF ELECTRO MECHANICAL IND., IS PROHIBITED.

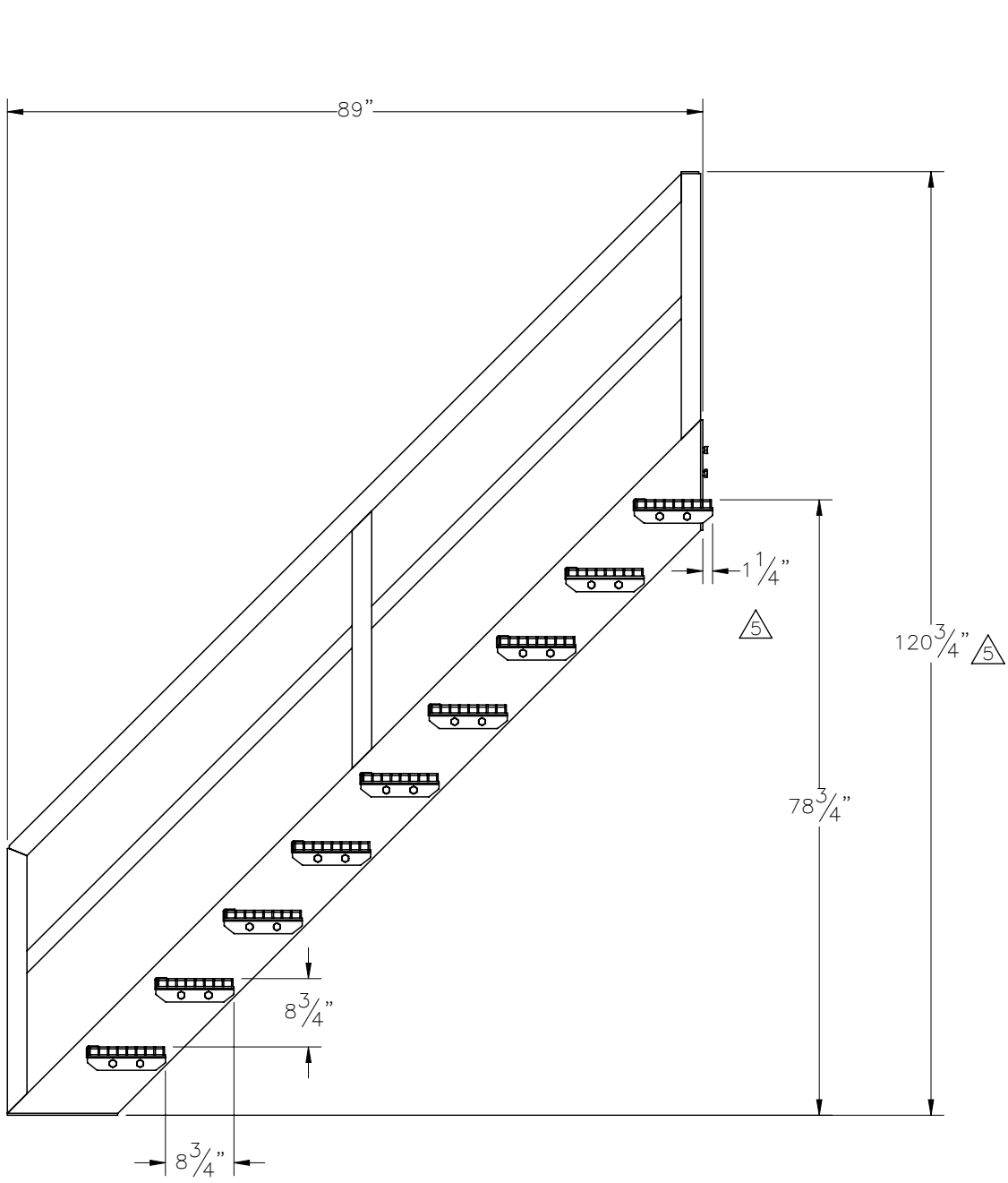

| REV. | DCN # | DESCRIPTION | DATE | BY | APPROVED |
|------|-------|---|------------|-----|----------|
| 5 | 01092 | 002-0BG-0026 TO 002-0BG-0010, 450-000-0160-0265 TO W-002-269, 450-000-0160-0266 TO W-002-270, W-001-864 UPDATED DUE TO LOWER LEVEL CHANGES, DIM'S ADDED FOR CLARITY/CONSISTENCY | 04/06/2022 | JTR | JPB |

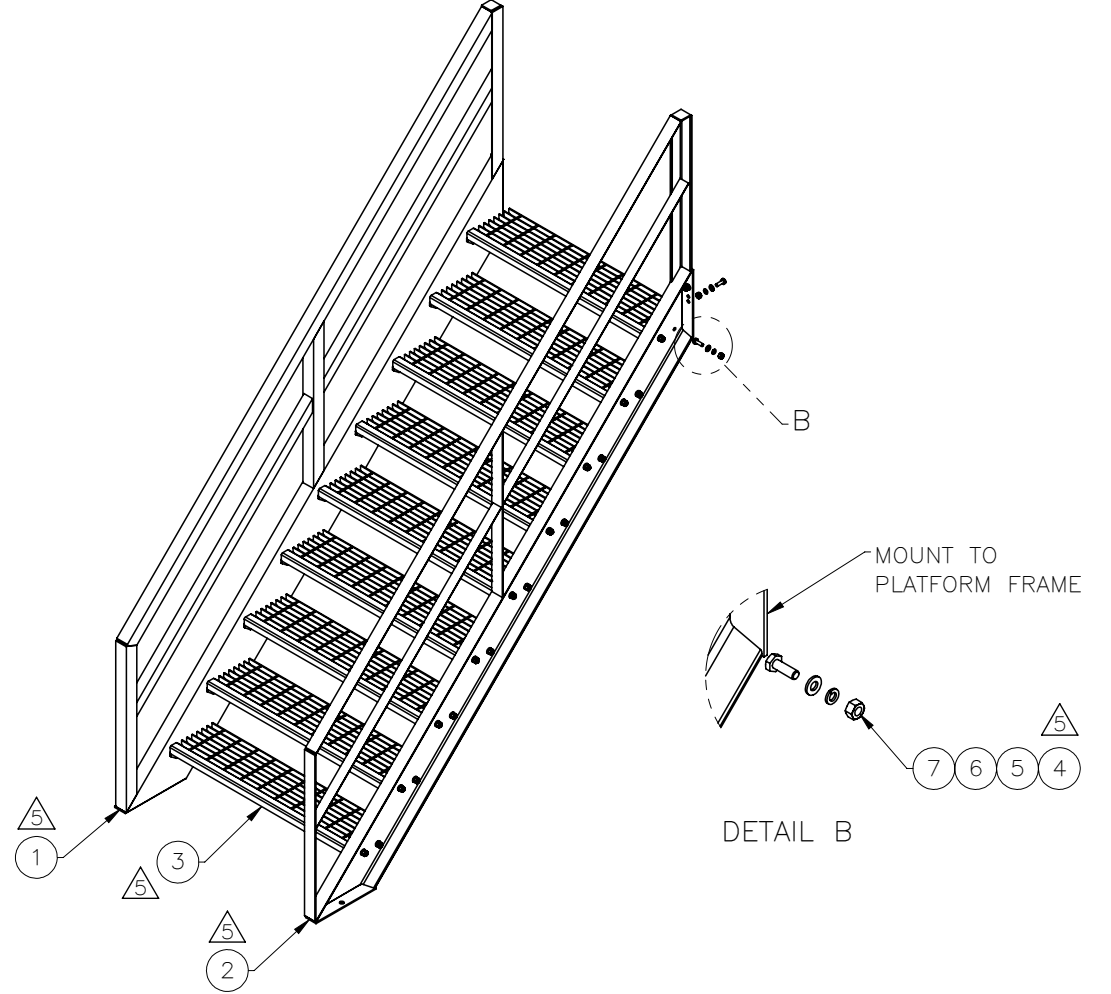
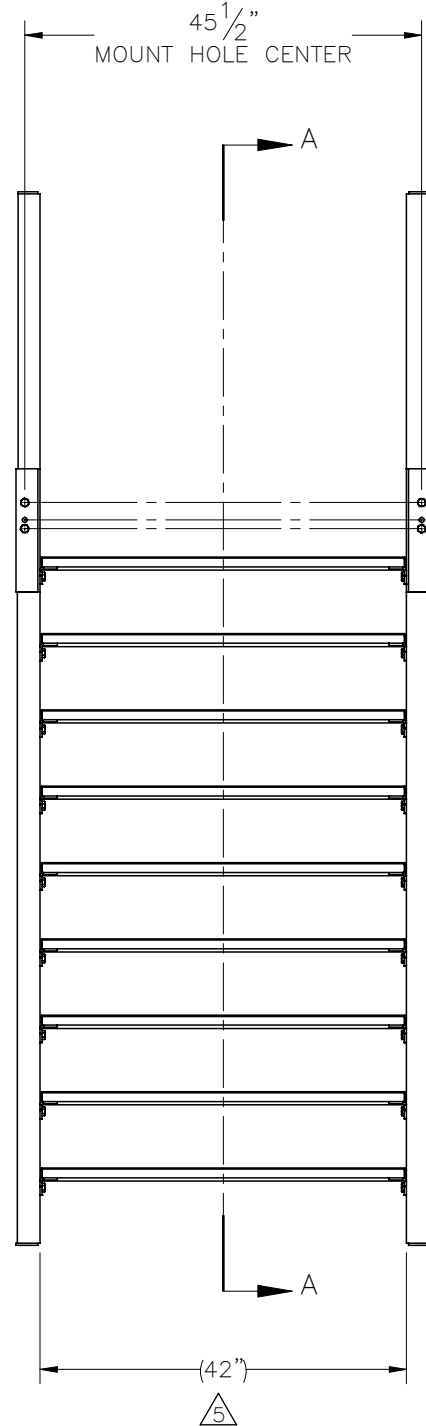

SECTION A-A



| ITEM NO. | Default QTY REQD | PART NUMBER | DESCRIPTION | LENGTH | WEIGHT |
|----------|------------------|--------------|---|--------|--------|
| 1 | 1 | W-002-269 | LEFT SIDE STAIR WELDMENT | | 257.1 |
| 2 | 1 | W-002-270 | RIGHT SIDE STAIR WELDMENT | | 257.1 |
| 3 | 9 | W-001-864 | 42" WD, STAIR TREAD WELDMT | | 29.82 |
| 4 | 40 | 002-0BG-0010 | HHB, .500-13 X 1.50 LG., PT X 1.00, A325, HDG | 1.50 | 0.14 |
| 5 | 40 | 002-0FW-G002 | FW, .50, F436, HDG | | 0.02 |
| 6 | 40 | 002-0LW-G002 | WASHER, SPLIT LOCK, .500", GALV | | 0.01 |
| 7 | 40 | 002-0NG-0010 | NUT, HEX, .500-13UNC, GR 2H, GALV | | 0.06 |

| | | | | | | |
|---|---|--|--|------------|------------|--|
| SURFACE FINISH <input checked="" type="checkbox"/> UNLESS OTHERWISE SPECIFIED | | UNLESS OTHERWISE SPECIFIED DIMENSIONS ARE IN INCHES | | APPROVALS | DATE |  ELECTRO MECHANICAL INDUSTRIES, INC. 11230 NEESESHAW DRIVE HOUSTON, TEXAS 77065 1-800-453-0050 |
| MATERIAL | SEE PARTS LIST | TOLERANCES | | DRAWN | 8/16/2011 | |
| THIRD ANGLE PROJECTION |  | .0 ±.06 .00 ±.015 .000 ±.005 | | CHECKER | 10/19/2011 | TITLE: 9 TREAD STAIR ASSY (42" WIDE) |
| NEXT ASSY | USED ON | FRACTIONS ± 1/16 ANGLES ± .25° | | ENGINEER | 10/19/2011 | |
| APPLICATIONS | | HOLES: DRILLED OR PUNCHED ± 1/32 BURNED ± 1/32 | | PRODUCTION | 10/20/2011 | SIZE B DRAWING NO. 450-000-0163 REV 5 SCALE: 1:22 WEIGHT: 792.2 lbs. SHEET 1 OF 1 |