

THE INFORMATION CONTAINED IN THIS DRAWING IS THE SOLE PROPERTY OF ELECTRO MECHANICAL INDUSTRIES, INC. ANY REPRODUCTION IN PART OR WHOLE WITHOUT THE WRITTEN PERMISSION OF ELECTRO MECHANICAL IND., IS PROHIBITED.

REVISIONS					
REV.	DCN #	DESCRIPTION	DATE	BY	APPROVED
5	01092	002-0BG-0026 TO .002-0BG-0010, W-001-989 AND W-001-990 UPDATED TO CONSOLIDATE WELDS, DIM'S ADDED/CHANGED FOR CONSISTANCY	11-23-21	JTR	JPB

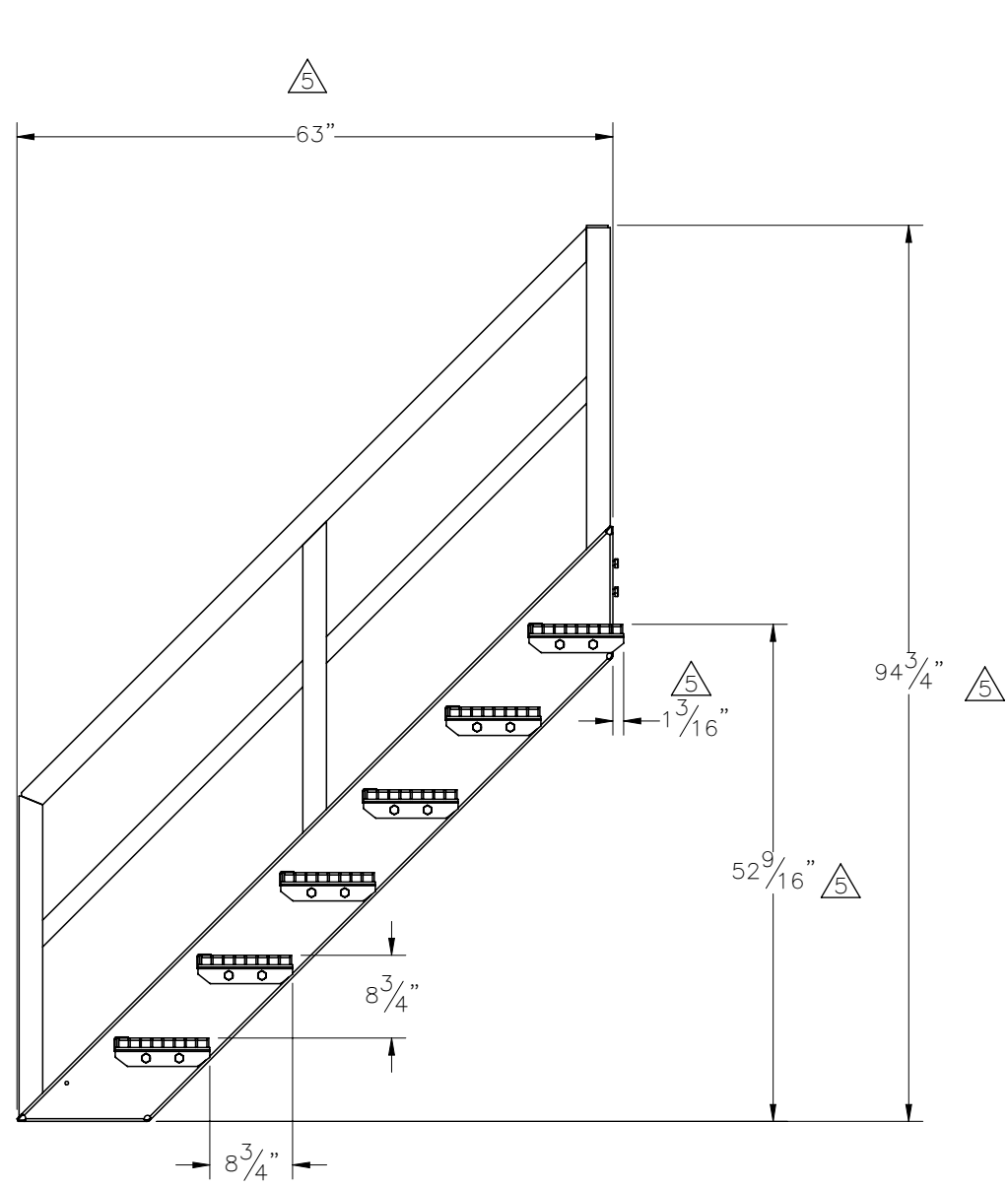

SECTION A-A

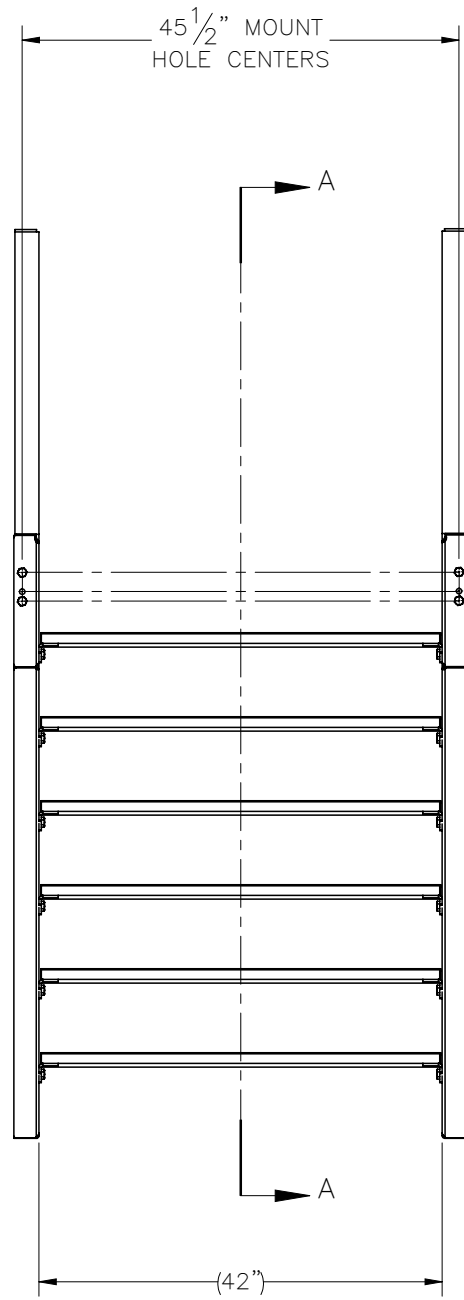

(42")

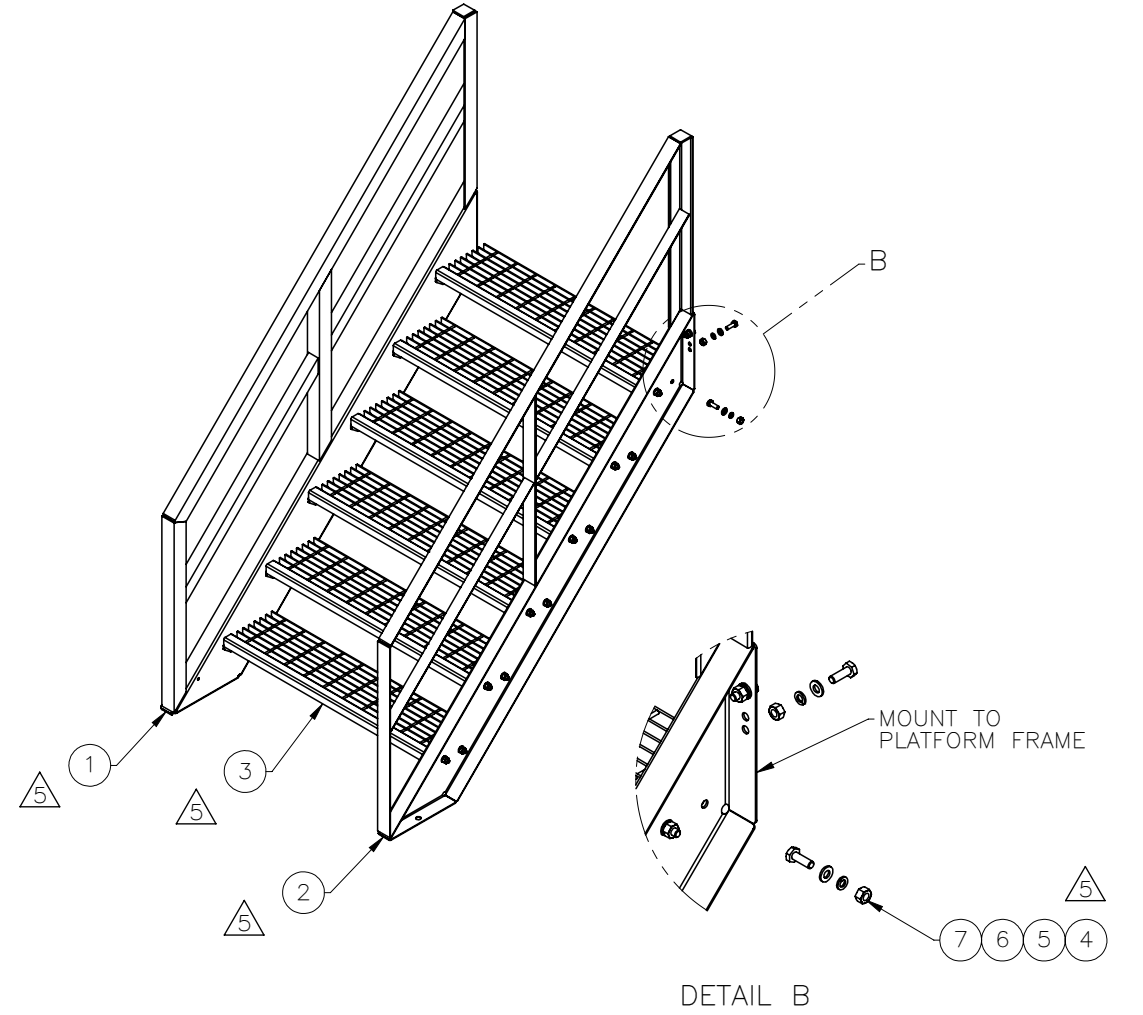

DETAIL B

ITEM NO.	Default QTY REQD	PART NUMBER	DESCRIPTION	LENGTH	WEIGHT
1	1	W-001-989	LEFT SIDE STAIR WELDMENT	111 1/16"	130.6
2	1	W-001-990	RIGHT SIDE STAIR WELDMENT	111 1/16"	130.4
3	6	W-001-864	42" WD, STAIR TREAD WELDMT		29.82
4	28	002-0BG-0010	HHB, .500-13 X 1.50 LG., PT X 1.00, A325, HDG	1.50	0.14
5	28	002-0FW-G002	FW, .50, F436, HDG		0.02
6	28	002-0LW-G002	WASHER, SPLIT LOCK, .500", GALV		0.01
7	28	002-0NG-0010	NUT, HEX, .500-13UNC, GR 2H, GALV		0.06

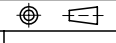
SURFACE FINISH <input checked="" type="checkbox"/> UNLESS OTHERWISE SPECIFIED		UNLESS OTHERWISE SPECIFIED DIMENSIONS ARE IN INCHES		APPROVALS		DATE		 ELECTRO MECHANICAL INDUSTRIES, INC. 11230 NEESEHAW DRIVE HOUSTON, TEXAS 77065 1-800-453-0050	
MATERIAL SEE PARTS LIST		TOLERANCES		DRAWN C. SANCHEZ		9/10/2012			
THIRD ANGLE PROJECTION 		FRACTIONS ± 1/16		CHECKER R. WOODARD		9/10/2012		TITLE: 6 TREAD STAIR ASSY (42" WIDE)	
NEXT ASSY USED ON		ANGLES ± .25°		ENGINEER C. SANCHEZ		9/10/2012			
APPLICATIONS		HOLES: DRILLED OR PUNCHED ± 1/32		PRODUCTION JKS		9/10/2012		SIZE B DRAWING NO. 450-000-0143 REV 5	
		BURNED ± 1/32						SCALE: 1:20 WEIGHT: 446.7 lbs. SHEET 1 OF 1	