

THE INFORMATION CONTAINED IN THIS DRAWING IS THE SOLE PROPERTY OF ELECTRO MECHANICAL INDUSTRIES, INC. ANY REPRODUCTION IN PART OR WHOLE WITHOUT THE WRITTEN PERMISSION OF ELECTRO MECHANICAL IND., IS PROHIBITED.

REVISIONS					
REV.	DCN #	DESCRIPTION	DATE	BY	APPROVED
2	01092	002-OBG-0026 TO 002-OBG-0010, W-001-989 AND W-001-990 UPDATED TO CONSOLIDATE WELDS, DIM'S ADDED/CHANGED FOR CONSISTANCY	11-16-21	JTR	JPB

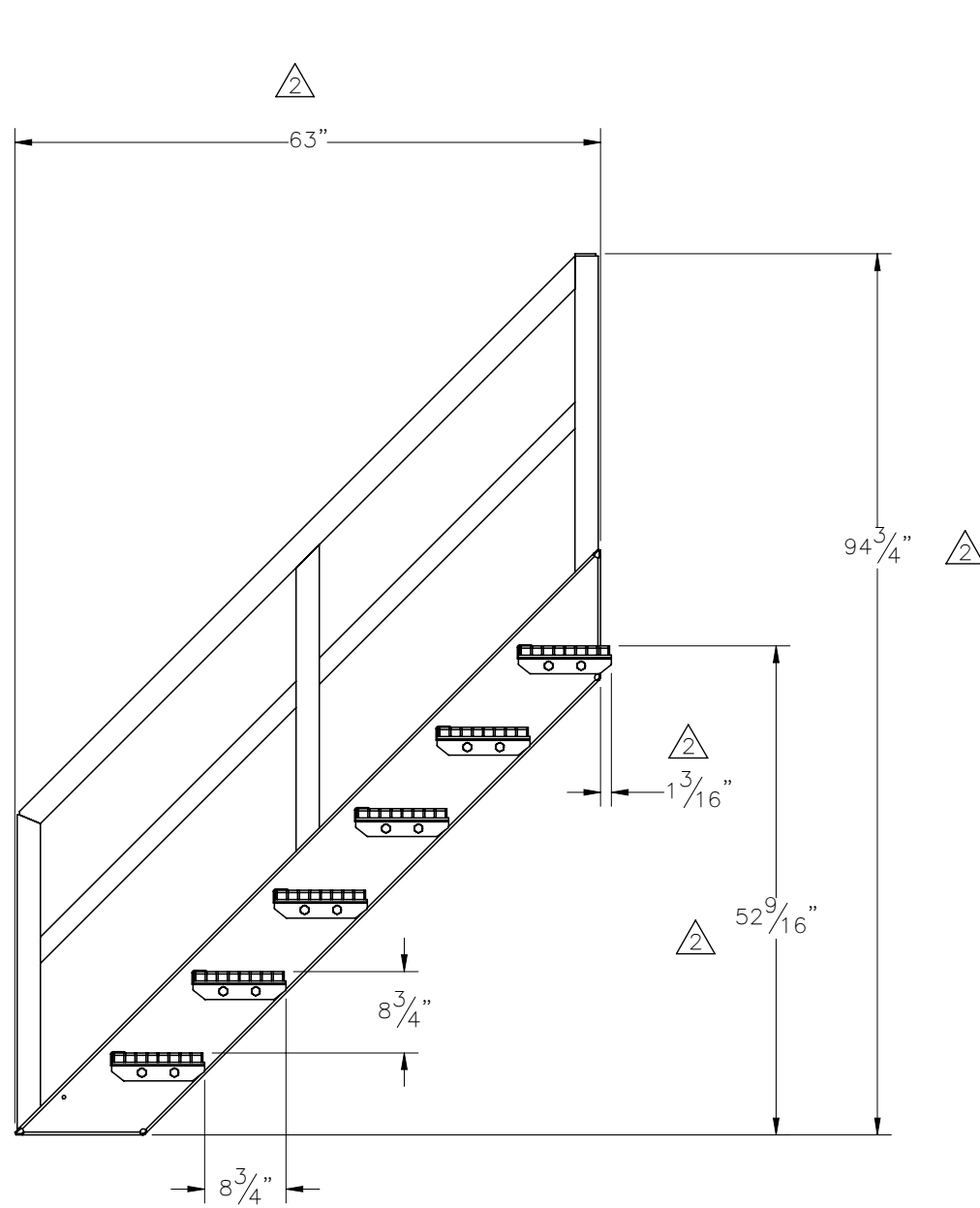

SECTION A-A

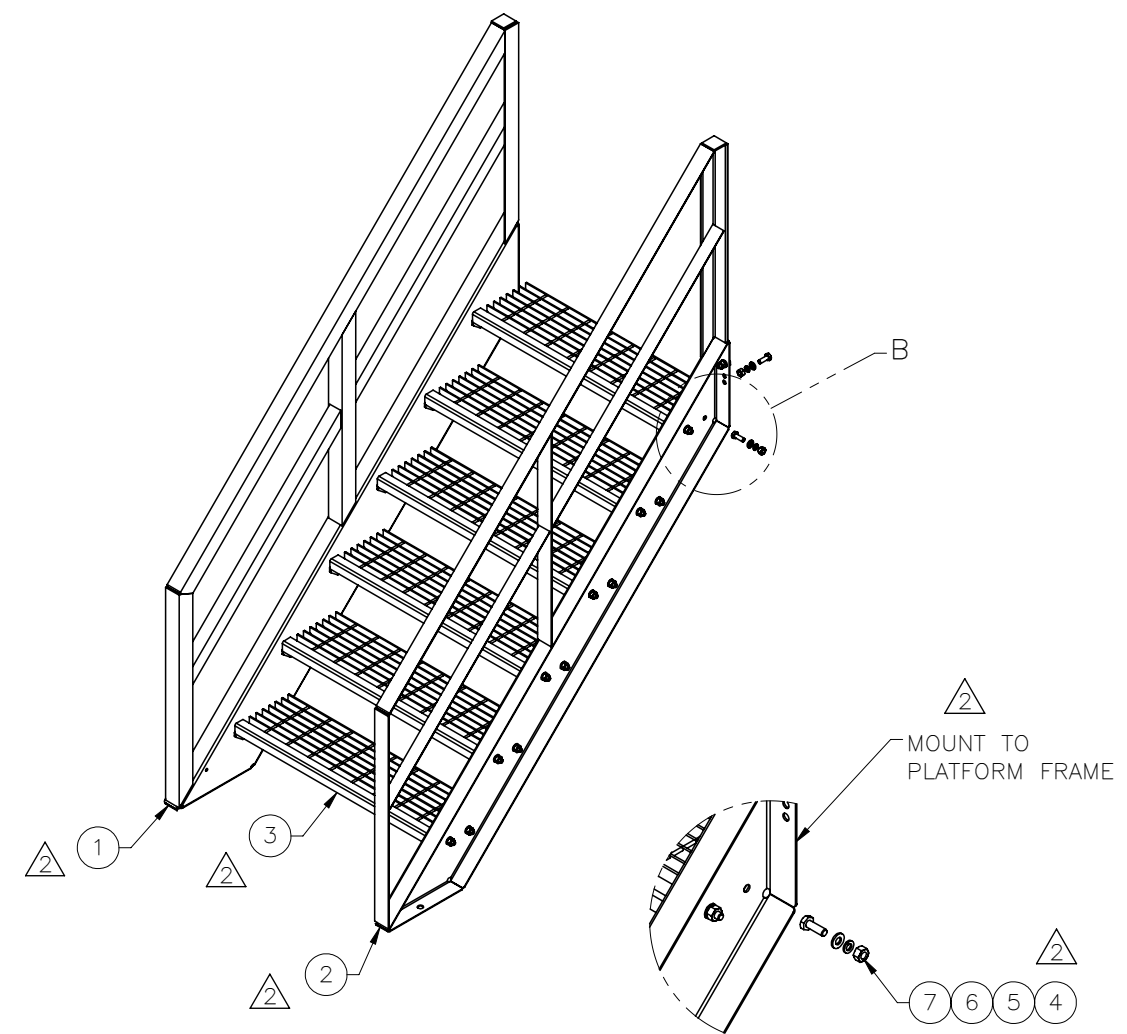
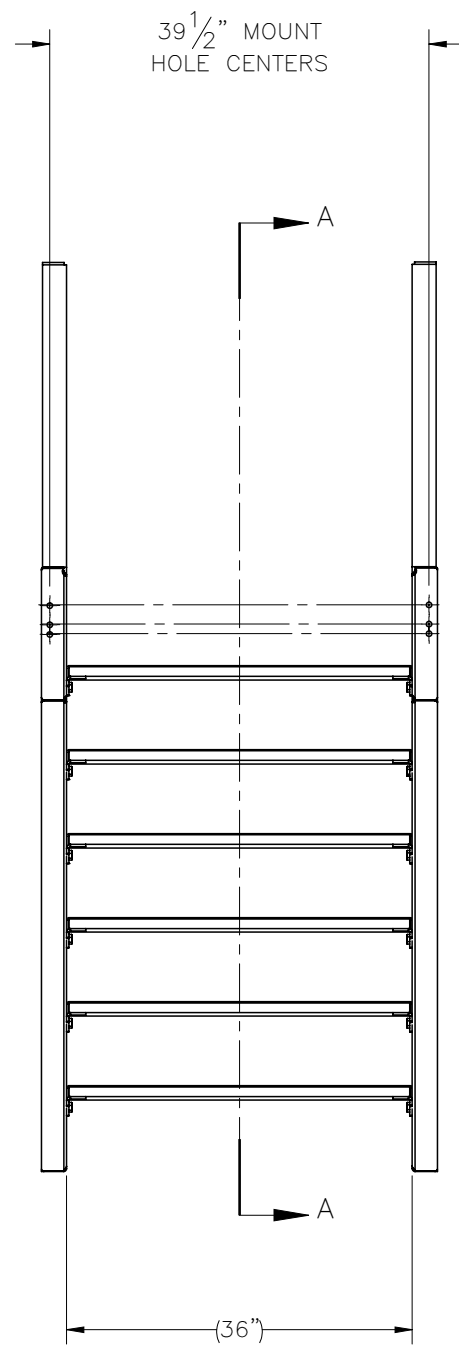

DETAIL B

ITEM NO.	QTY	PART NUMBER	DESCRIPTION	LENGTH	WEIGHT
1	1	W-001-989	LEFT SIDE STAIR WELDMENT	111 1/16"	130.6
2	1	W-001-990	RIGHT SIDE STAIR WELDMENT	111 1/16"	130.4
3	6	W-001-873	36" WD STAIR TREAD WELDMENT	36	26.16
4	28	002-OBG-0010	HHB, .500-13 X 1.50 LG., PT X 1.00, A325, HDG	1.50	0.14
5	28	002-OFW-G002	FW, .50, F436, HDG		0.02
6	28	002-OLW-G002	WASHER, SPLIT LOCK, .500", GALV		0.01
7	28	002-ONG-0010	NUT, HEX, .500-13UNC, GR 2H, GALV		0.06

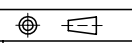
SURFACE FINISH <input checked="" type="checkbox"/> UNLESS OTHERWISE SPECIFIED		UNLESS OTHERWISE SPECIFIED DIMENSIONS ARE IN INCHES		APPROVALS		DATE		 ELECTRO MECHANICAL INDUSTRIES, INC. 11230 NEESESHAW DRIVE HOUSTON, TEXAS 77065 1-800-453-0050	
MATERIAL SEE PARTS LIST		TOLERANCES		DRAWN CS		2/7/2017			
THIRD ANGLE PROJECTION 		.0 ±.06 .00 ±.015 .000 ±.005		CHECKER C. SANCHEZ		2/7/2017		TITLE: 6 TREAD STAIR ASS'Y (36" WIDE)	
NEXT ASSY USED ON		FRACTIONS ± 1/16 ANGLES ± .25°		ENGINEER C. SANCHEZ		2/7/2017			
APPLICATIONS		HOLES: DRILLED OR PUNCHED ± 1/32 BURNED ± 1/32		PRODUCTION JAB		2/7/2017		SIZE B DRAWING NO. 450-000-0142 REV 2 SCALE: 1:25 WEIGHT: 424.7 lbs. SHEET 1 OF 1	