

THE INFORMATION CONTAINED IN THIS DRAWING IS THE SOLE PROPERTY OF ELECTRO MECHANICAL INDUSTRIES, INC. ANY REPRODUCTION IN PART OR WHOLE WITHOUT THE WRITTEN PERMISSION OF ELECTRO MECHANICAL IND., IS PROHIBITED.

REVISIONS					
REV.	DCN #	DESCRIPTION	DATE	BY	APPROVED
1	01179	ADDED LEVELING HARDWARE KIT 1000-0020-0078 WELDMENT ITEMS MOVED TO NEW W-002-462	9/8/2022	JTR	JPB

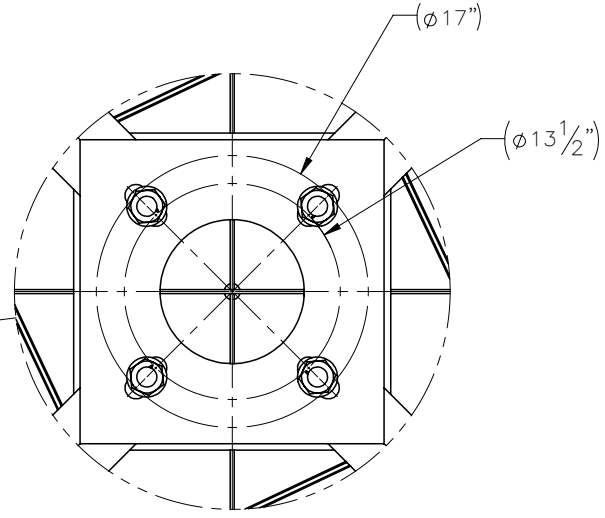

DETAIL B

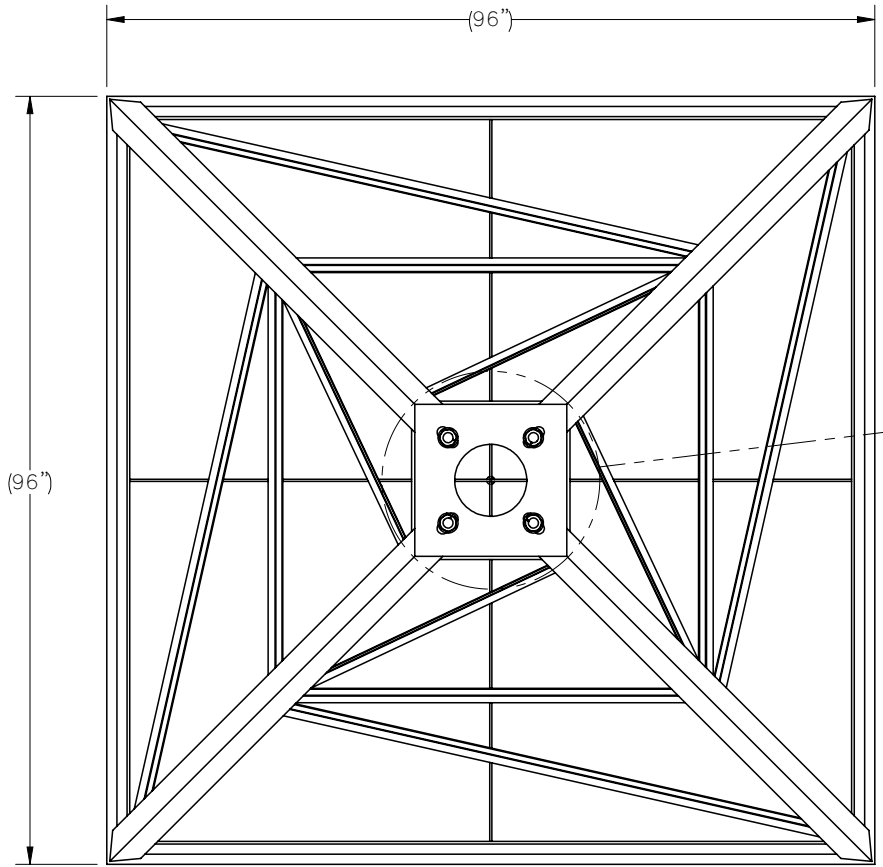
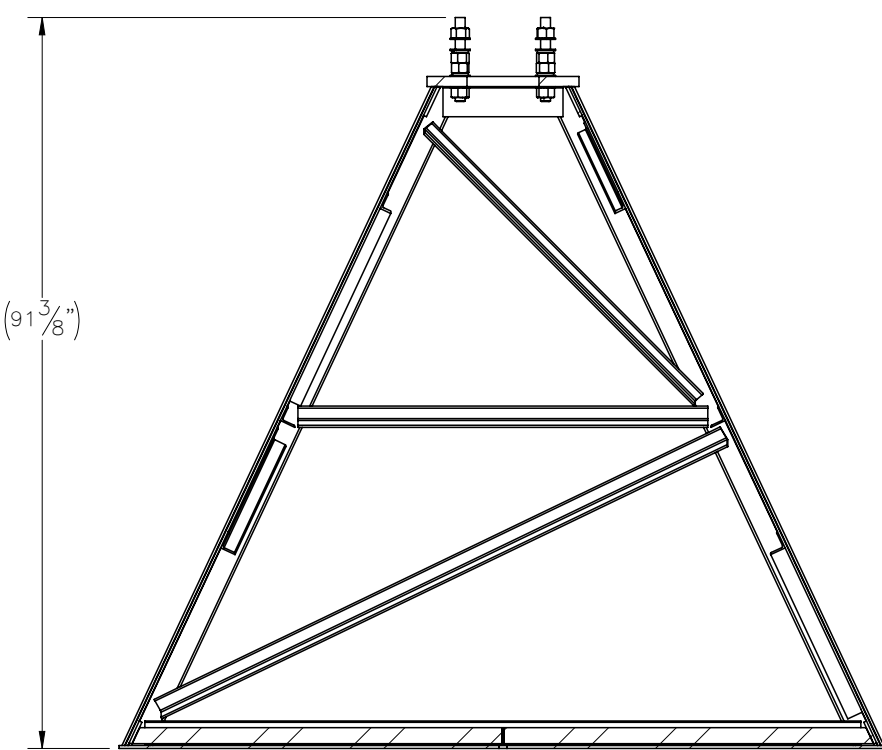
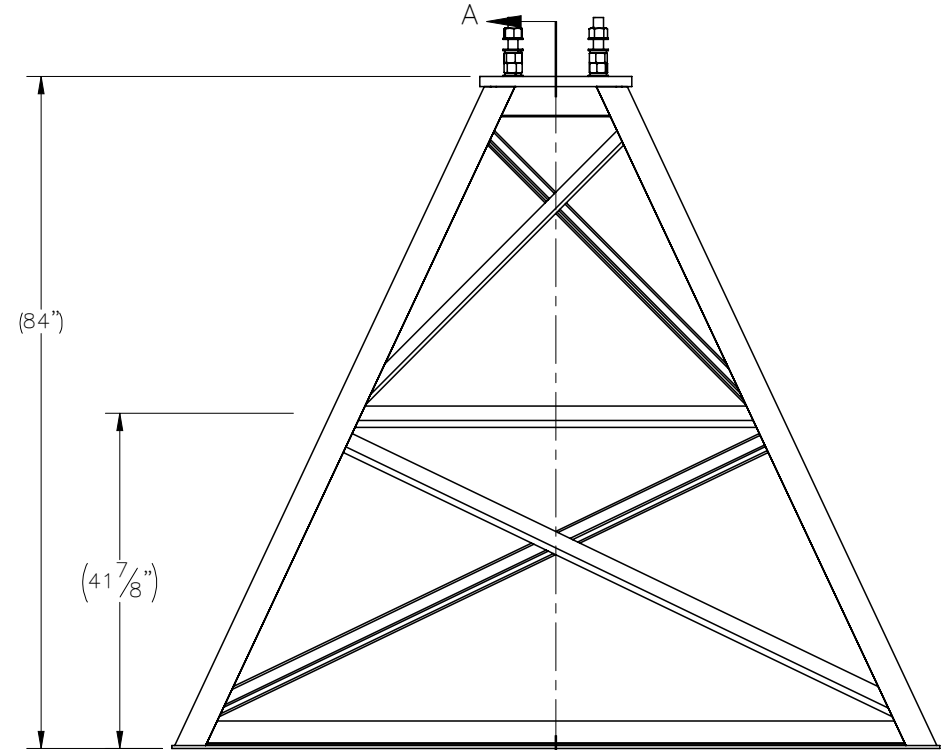
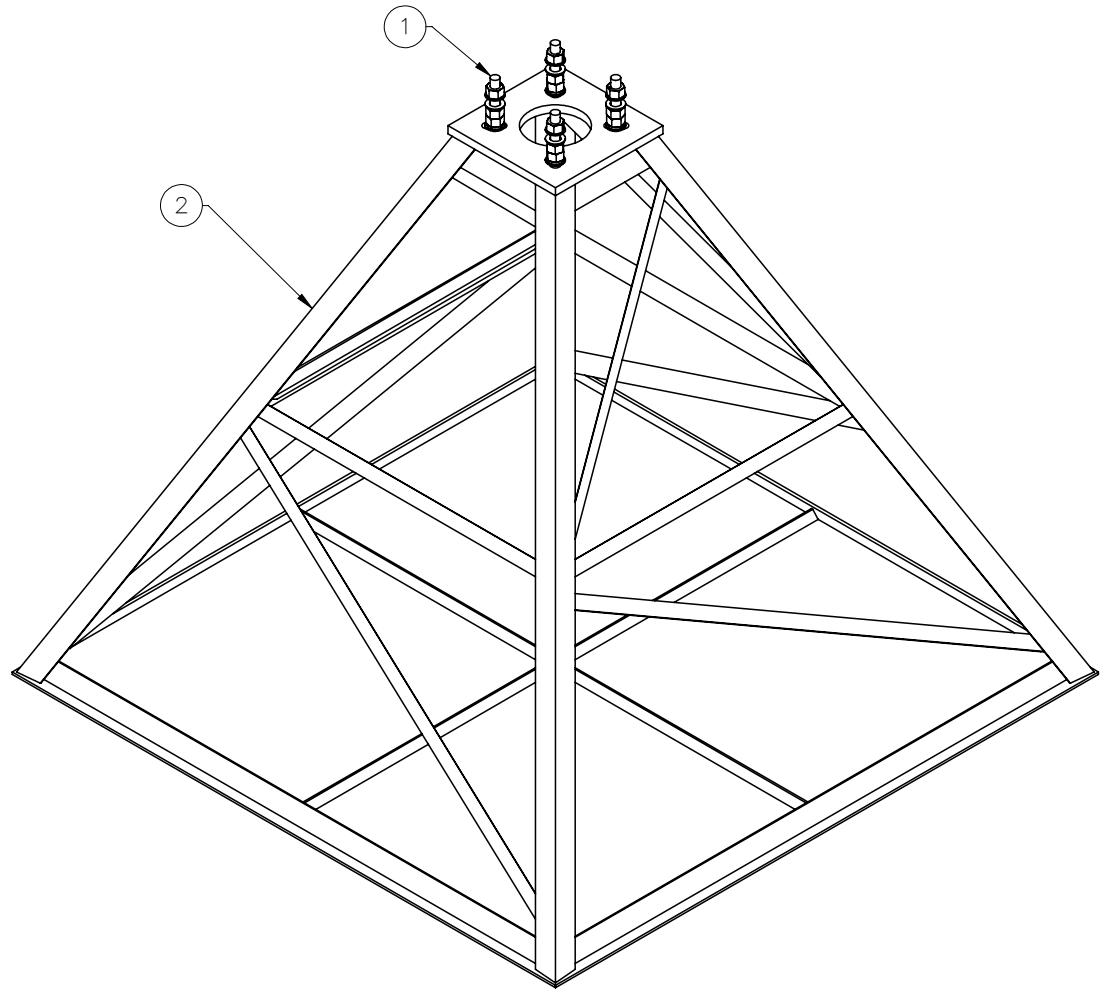

SECTION A-A

ITEM NO.	QTY REQD	PART NUMBER	DESCRIPTION	LENGTH	WEIGHT
1	1	1000-0020-0078	QUAD 1.25" STUD LEVELING KIT		30.80
2	1	W-002-462	WELDMENT, STEEL FRAME FOUNDATION		1656.97

SURFACE FINISH	UNLESS OTHERWISE SPECIFIED	UNLESS OTHERWISE SPECIFIED DIMENSIONS ARE IN INCHES	APPROVALS	DATE
MATERIAL	SEE PARTS LIST	TOLERANCES	DRAWN	12/6/2012
THIRD ANGLE PROJECTION		.0 ± .06 .00 ± .015 .000 ± .005	CHECKER	12/13/2012
		FRACTIONS ± 1/16	ENGINEER	1/4/2013
		ANGLES ± .25°	PRODUCTION	1/8/2013
NEXT ASSY	USED ON	HOLES: DRILLED OR PUNCHED ± 1/32	JKS	
APPLICATIONS		BURNED ± 1/32		

TITLE:		ELECTRO MECHANICAL INDUSTRIES, INC. 11230 NEESESHAW DRIVE HOUSTON, TEXAS 77065 1-800-453-0050	
STEEL FRAME FOUNDATION - 80' TOWER		SIZE	REV
		B	1
SCALE: 1:32	WEIGHT: 1687.77 lbs.	DRAWING NO. 400-000-3504	
		SHEET 1 OF 1	