

THE INFORMATION CONTAINED IN THIS DRAWING IS THE SOLE PROPERTY OF ELECTRO MECHANICAL INDUSTRIES, INC. ANY REPRODUCTION IN PART OR WHOLE WITHOUT THE WRITTEN PERMISSION OF ELECTRO MECHANICAL IND., IS PROHIBITED.

REVISIONS					
REV.	DCN #	DESCRIPTION	DATE	BY	APPROVED
1	DCN00225	CREATED NEW VERSION W/ HARDWARE	1.4.17	JGC	<i>CS</i>

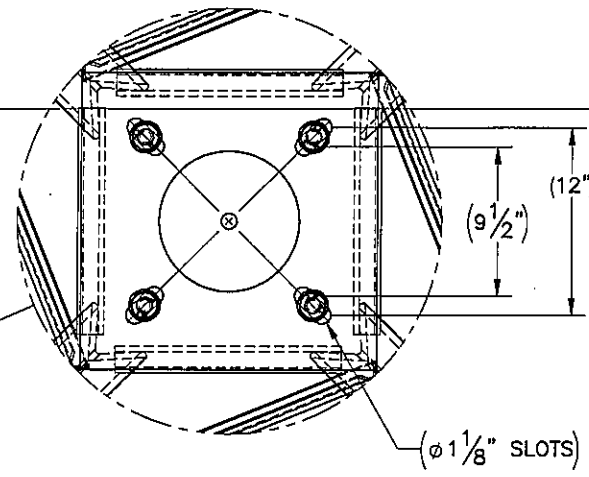

DETAIL B

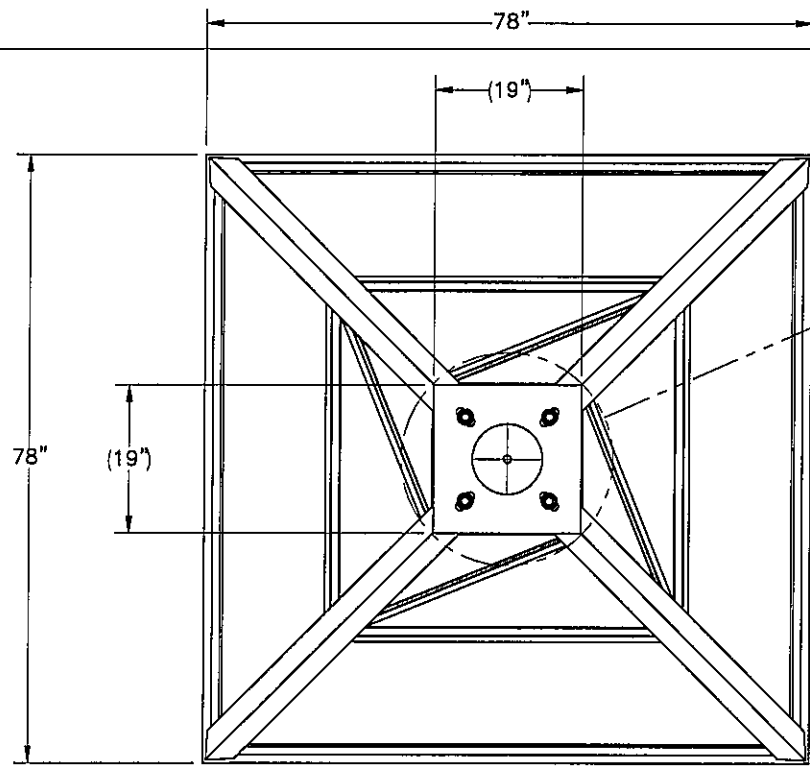
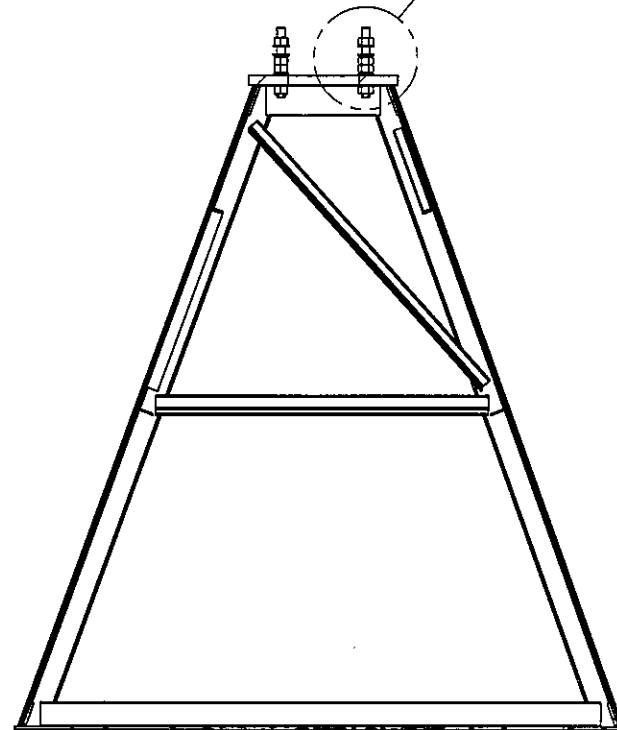
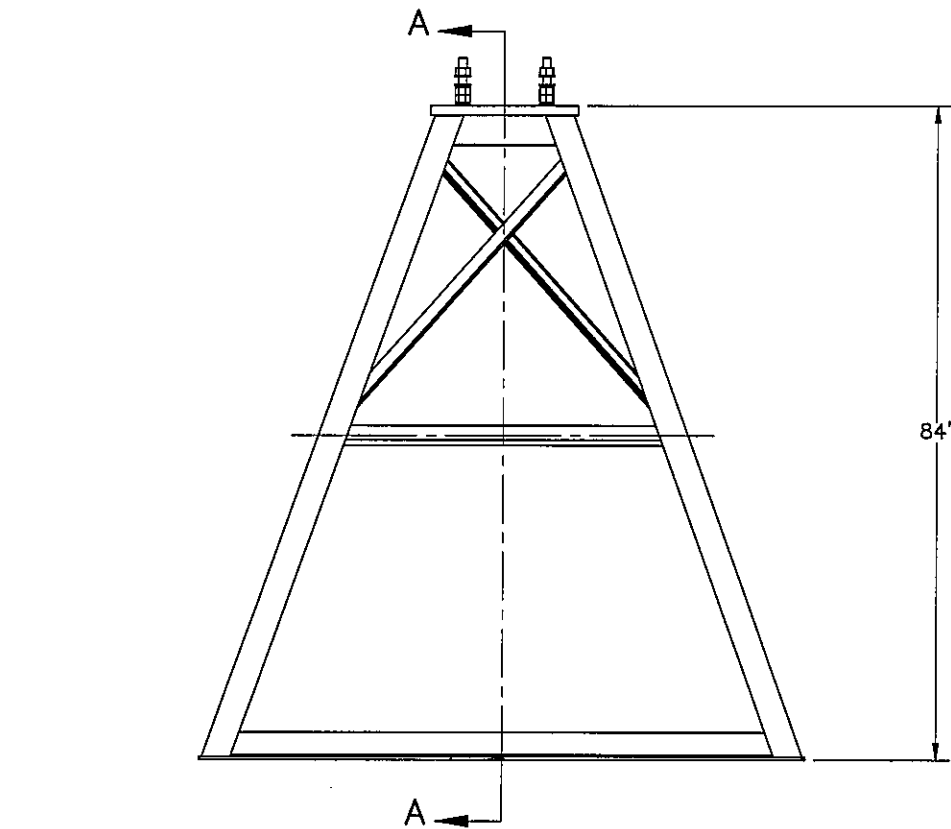
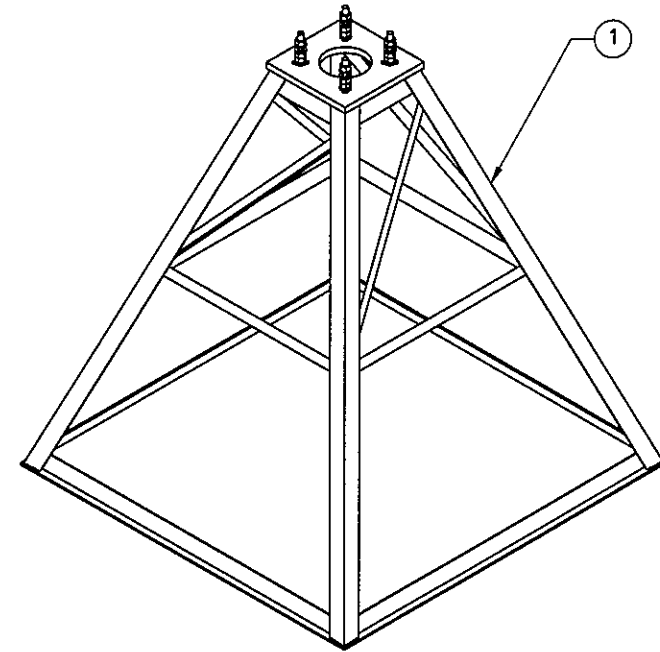

SECTION A-A

- 2
- 3
- 6
- 6
- 5
- 4
- 4
- 6
- 6
- 3

ITEM NO.	QTY.	PART NUMBER	DESCRIPTION
1	1	400-000-3502-0100	STEEL FRAME FOUNDATION
2	4	002-OAT-H000	ROD, THREADED, 1.00"-8 X 9.00" LG, ASTM A193 B7, GALV
3	8	002-ONG-0000	NUT, HX, ANCO LOCK, 1.00"-8UNC, GR 2H, GALV
4	8	002-ONG-0008	NUT, HX, 1.00"-8UNC, GR 2H, GALV
5	8	002-OLW-G008	WASHER, SPLIT LOCK, 1.00", GALV
6	16	002-OFW-G009	WASHER, FLAT, 1.00", F436, GALV

SURFACE FINISH <input checked="" type="checkbox"/> UNLESS OTHERWISE SPECIFIED		UNLESS OTHERWISE SPECIFIED DIMENSIONS ARE IN INCHES		APPROVALS		DATE	
MATERIAL SEE PARTS LIST		TOLERANCES		DRAWN CS		6.05.11	
THIRD ANGLE PROJECTION		FRACTIONS ± 1/16		CHECKED VGD		2.27.12	
NEXT ASSY		HOLES: DRILLED OR PUNCHED		ENGINEER/DESIGNER VGD		2.27.12	
USED ON		BURNED ± 1/32		PRODUCTION JKS		2.29.12	
APPLICATIONS				ELECTRO MECHANICAL INDUSTRIES, INC. 11230 NEESEHAW DRIVE HOUSTON, TEXAS 77065 1-800-453-0050		TITLE: STEEL FRAME FOUNDATION W/ HARDWARE	
				SIZE B		DRAWING NO. 400-000-3502	
				SCALE: 1:32		WEIGHT: 1200.23 lbs.	
						REV 1 SHEET 1 OF 1	