

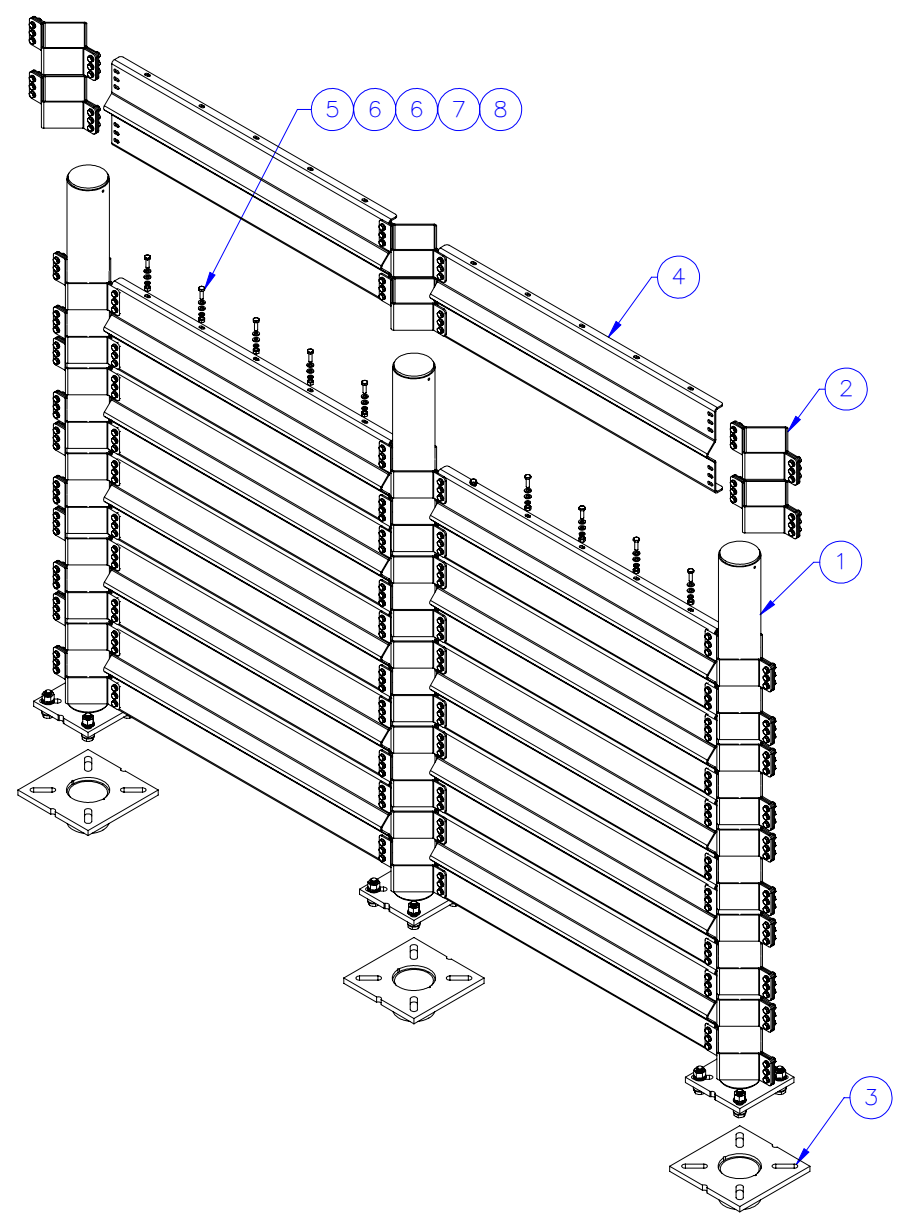

THE INFORMATION CONTAINED IN THIS DRAWING IS THE SOLE PROPERTY OF ELECTRO MECHANICAL INDUSTRIES, INC. ANY REPRODUCTION IN PART OR WHOLE WITHOUT THE WRITTEN PERMISSION OF ELECTRO MECHANICAL IND., IS PROHIBITED.

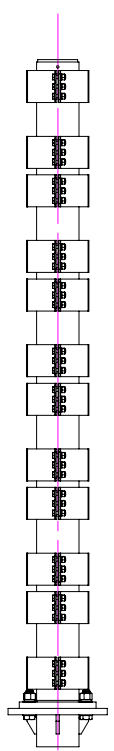
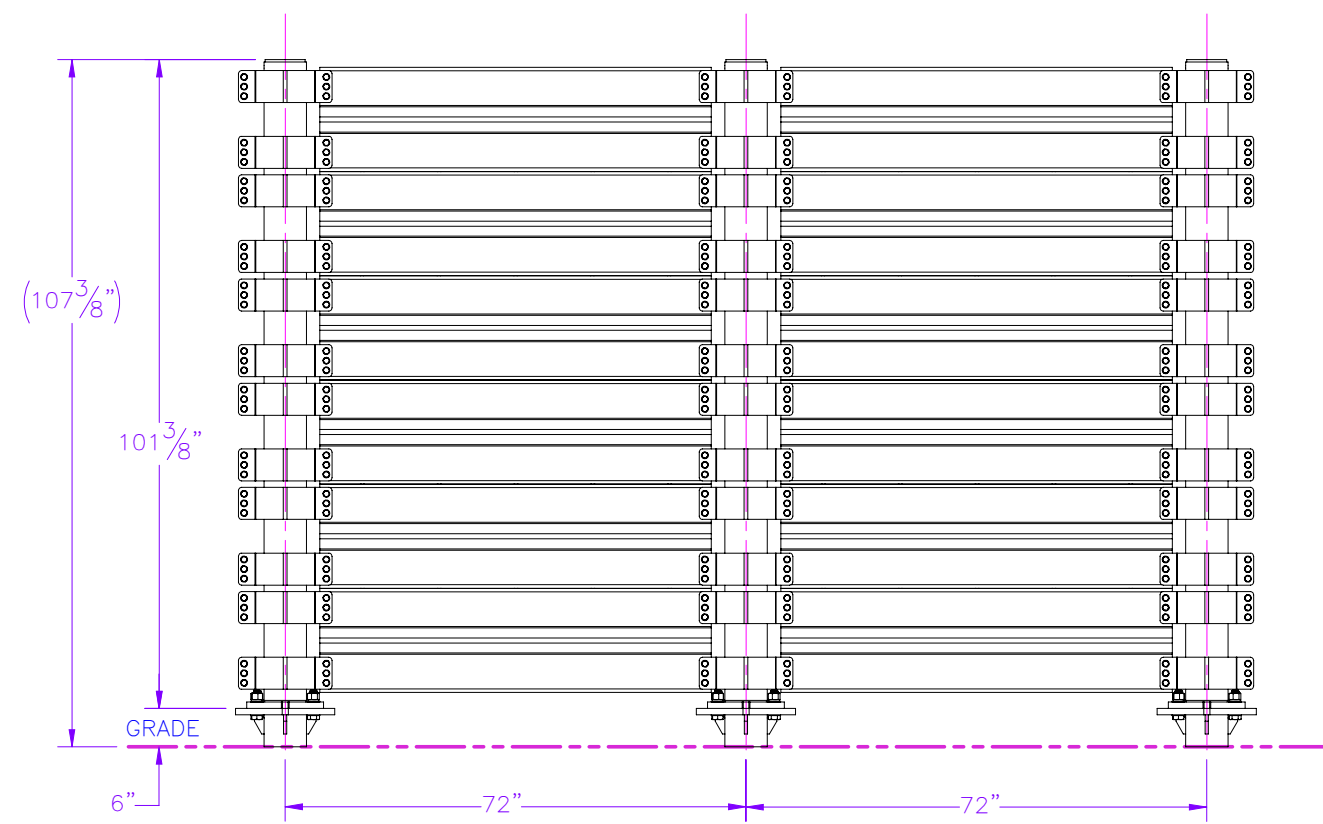
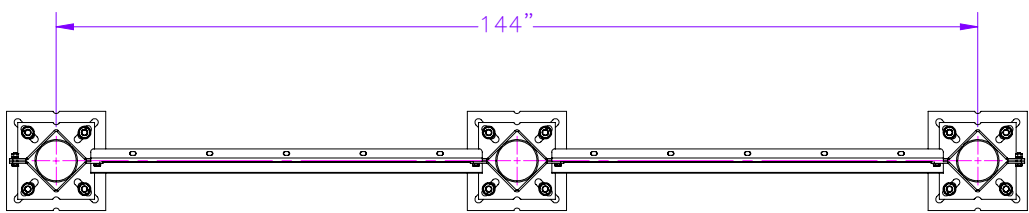
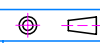

ITEM NO.	QTY REQD	PART NUMBER	DESCRIPTION	LENGTH	WEIGHT
1	3	1007-0000-0042	STRAIGHT POST KIT, 101" TALL, RETAINING WALL		199.5
2	36	1000-0030-0105	STRAIGHT CLAMP KIT, RETAINING WALL		14.40
3	3	W-001-878	6" X 7' HELICAL WELDMENT WITH 16" HELICAL GUSSETED		214.07
4	12	P-005-960	FORMED PANEL, 16 1/4" TALL, RETAINER WALL		89.52
5	50	002-0BG-0303	HHB .500-13UNC X 1.75 LG., FT, A325, HDG	1 3/4"	0.00
6	100	002-0FW-G002	FW, .50, F436, HDG		0.02
7	50	002-0LW-G002	WASHER, SPLIT LOCK, .500", GALV		0.01
8	50	002-0NG-0010	NUT, HEX, .500-13UNC, GR 2H, GALV		0.06

SURFACE FINISH <input checked="" type="checkbox"/> UNLESS OTHERWISE SPECIFIED		UNLESS OTHERWISE SPECIFIED DIMENSIONS ARE IN INCHES		APPROVALS	DATE	 ELECTRO MECHANICAL INDUSTRIES, INC. 11230 NEESESHAW DRIVE HOUSTON, TEXAS 77065 1-800-453-0050
MATERIAL	SEE PARTS LIST	TOLERANCES		DRAWN	7/12/2023	
THIRD ANGLE PROJECTION		.0 ± .06 .00 ± .015 .000 ± .005		CHECKER	7/12/2023	TITLE: 8' X 12' RETAINING WALL, ASSEMBLY
NEXT ASSY	USED ON	FRACTIONS ± 1/16 ANGLES ± .25°		ENGINEER	7/12/2023	
APPLICATIONS		HOLES: DRILLED OR PUNCHED ± 1/32 BURNED ± 1/32		PRODUCTION	7/12/2023	SIZE B DRAWING NO. 1010-0010-0212 REV - SCALE: 1:30 WEIGHT: 2395.83 lbs. SHEET 1 OF 1