

THE INFORMATION CONTAINED IN THIS DRAWING IS THE SOLE PROPERTY OF ELECTRO MECHANICAL INDUSTRIES, INC. ANY REPRODUCTION IN PART OR WHOLE WITHOUT THE WRITTEN PERMISSION OF ELECTRO MECHANICAL IND., IS PROHIBITED.

REVISIONS					
REV.	DCN #	DESCRIPTION	DATE	BY	APPROVED
1	01252	UPDATED STRAIGHT AND CORNER POST KIT QTY., UPDATED HARDWARE QTY., REPLACED HELICAL ASSEMBLY	7/13/23	PG	WSD

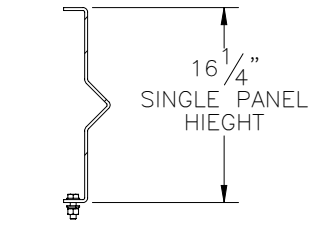

SECTION A-A
PANEL PROFILE

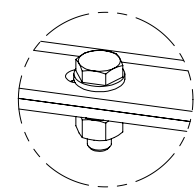

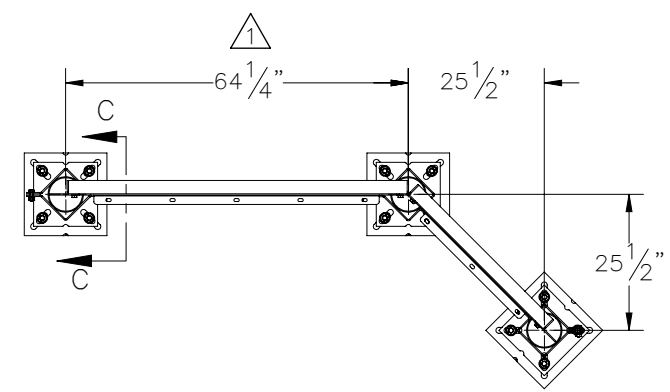

PANEL CONNECTION
DETAIL B

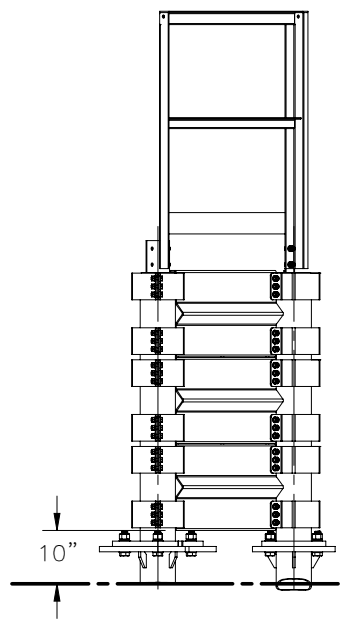
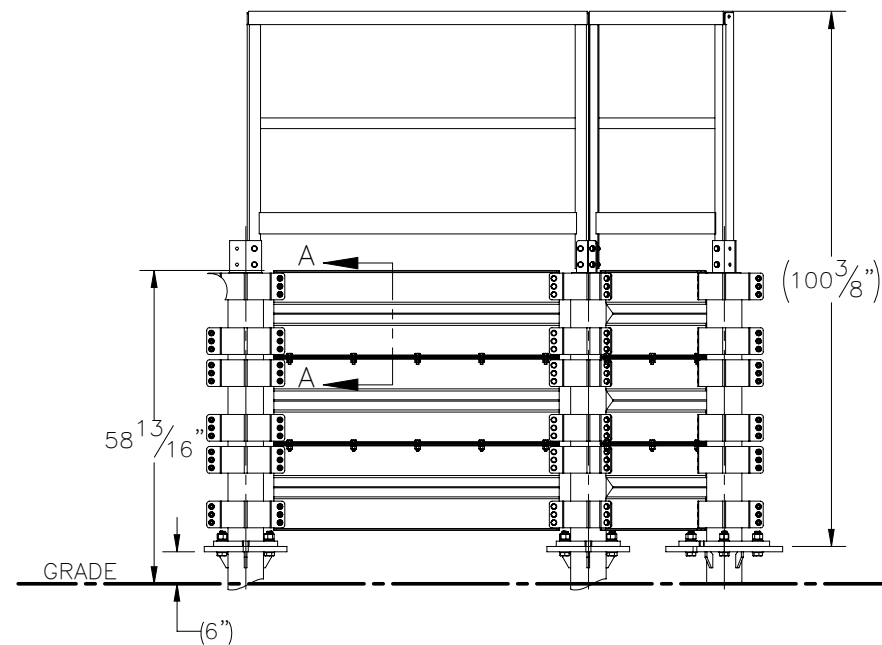
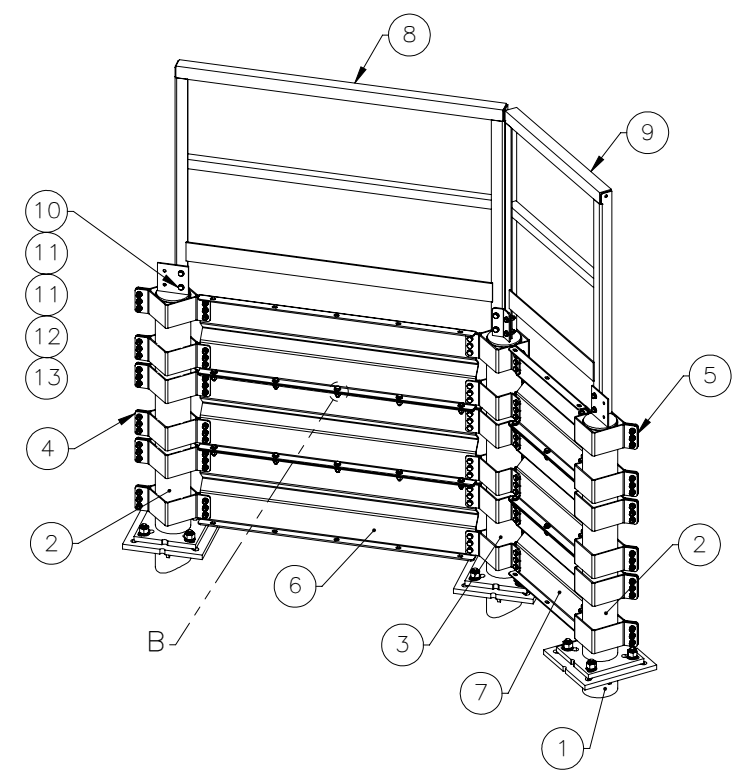

HANDRAIL CONNECTION
SECTION C-C



ITEM NO.	QTY REQD	PART NUMBER	DESCRIPTION	LENGTH	WEIGHT
1	3	W-001-878	6" X 7" HELICAL WELDMENT WITH 16" HELICAL GUSSETED		214.07
2	2	1007-0000-0037	STRAIGHT POST KIT, 50" TALL, RETAINING WALL		122.8
3	1	1007-0000-0038	CORNER POST KIT, 50" TALL, RETAINING WALL		122.1
4	6	1000-0030-0105	STRAIGHT CLAMP KIT, RETAINING WALL		14.39
5	12	1000-0030-0106	CORNER CLAMP KIT, RETAINING WALL		14.54
6	3	P-005-575	FORMED PANEL, 16" TALL, RETAINER WALL	53 1/2"	78.91
7	3	P-006-047	FORMED PANEL, 16" TALL, RETAINER WALL	26 1/2"	38.80
8	1	1004-T001-0640	ANGLE GUARDRAIL, 64	64"	85.33
9	1	1004-T001-0360	ANGLE GUARDRAIL, 36	36"	60.63
10	24	002-0BG-0303	HHB .500-13UNC X 1.75 LG., FT, A325, HDG	1 3/4"	0.2
11	48	002-0FW-G002	FW, .50, F436, HDG		0.02
12	24	002-0LW-G002	WASHER, SPLIT LOCK, .500", GALV		0.01
13	24	002-0NG-0010	NUT, HEX, .500-13UNC, GR 2H, GALV		0.06

SURFACE FINISH <input checked="" type="checkbox"/> UNLESS OTHERWISE SPECIFIED		UNLESS OTHERWISE SPECIFIED DIMENSIONS ARE IN INCHES		APPROVALS		DATE		 ELECTRO MECHANICAL INDUSTRIES, INC. 11230 NEESEAW DRIVE HOUSTON, TEXAS 77065 1-800-453-0050	
MATERIAL SEE PARTS LIST		TOLERANCES .0 ±.06 .00 ±.015 .000 ±.005 FRACTIONS ± 1/16 ANGLES ± .25° HOLES: DRILLED OR PUNCHED ± 1/32 BURNED ± 1/32		DRAWN RLWjr		7/22/2022			
THIRD ANGLE PROJECTION 		NEXT ASSY		USED ON		CHECKER S. DILLARD		7/25/2022	
APPLICATIONS		PRODUCTION J. KERNER		7/25/2022		SIZE B		DRAWING NO. 1010-0000-0196	
						SCALE: 1:36		WEIGHT: 1330.13 lbs.	
								REV 1	
								SHEET 1 OF 1	