

THE INFORMATION CONTAINED IN THIS DRAWING IS THE SOLE PROPERTY OF ELECTRO MECHANICAL INDUSTRIES, INC. ANY REPRODUCTION IN PART OR WHOLE WITHOUT THE WRITTEN PERMISSION OF ELECTRO MECHANICAL IND., IS PROHIBITED.

| REVISIONS | | | | | |
|-----------|-------|---|----------|-----|----------|
| REV. | DCN # | DESCRIPTION | DATE | BY | APPROVED |
| 4 | 01092 | 002-OBG-0026 TO 002-OBG-0010, W-001-987 AND W-001-988 UPDATED TO CONSOLIDATE WELDS, DIM'S ADDED FOR CONSISTANCY | 11-16-21 | JTR | JPB |

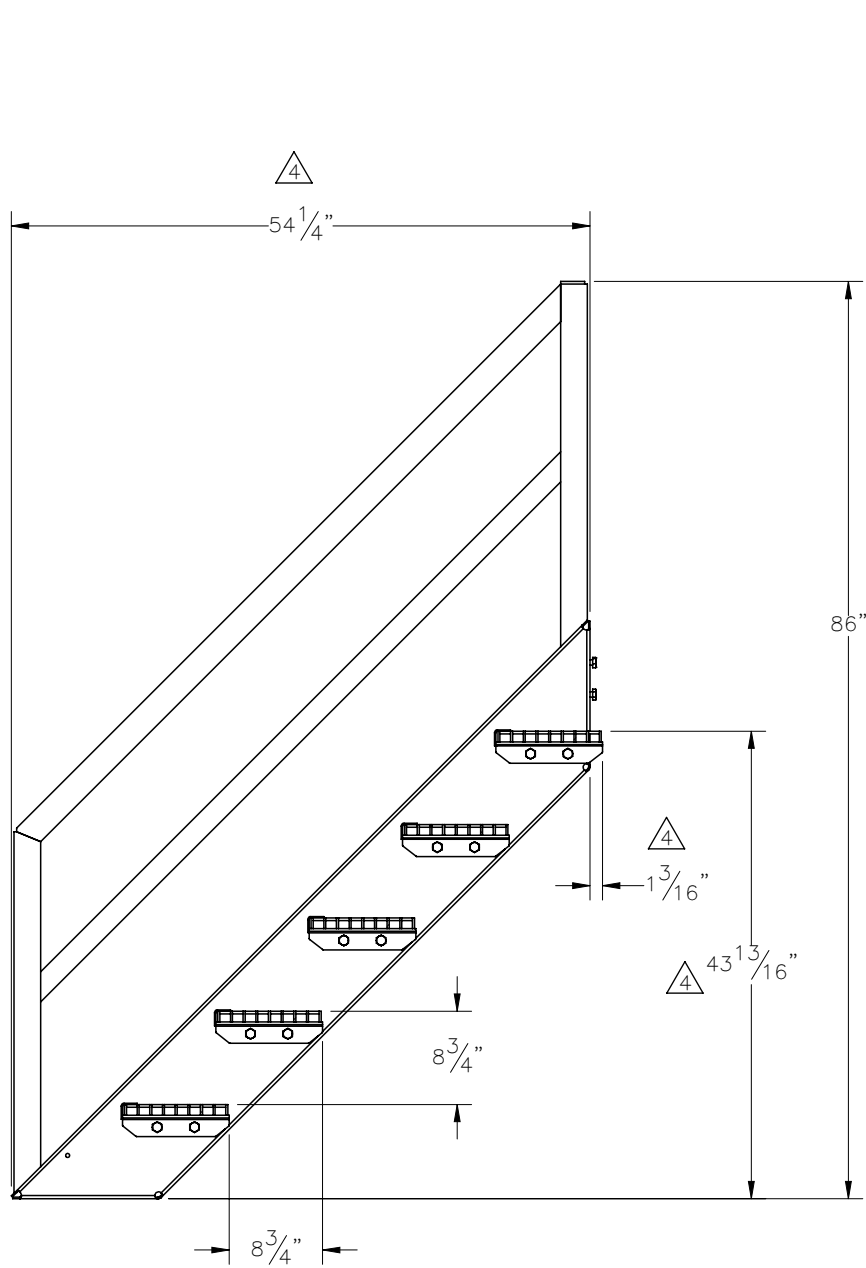

SECTION A-A

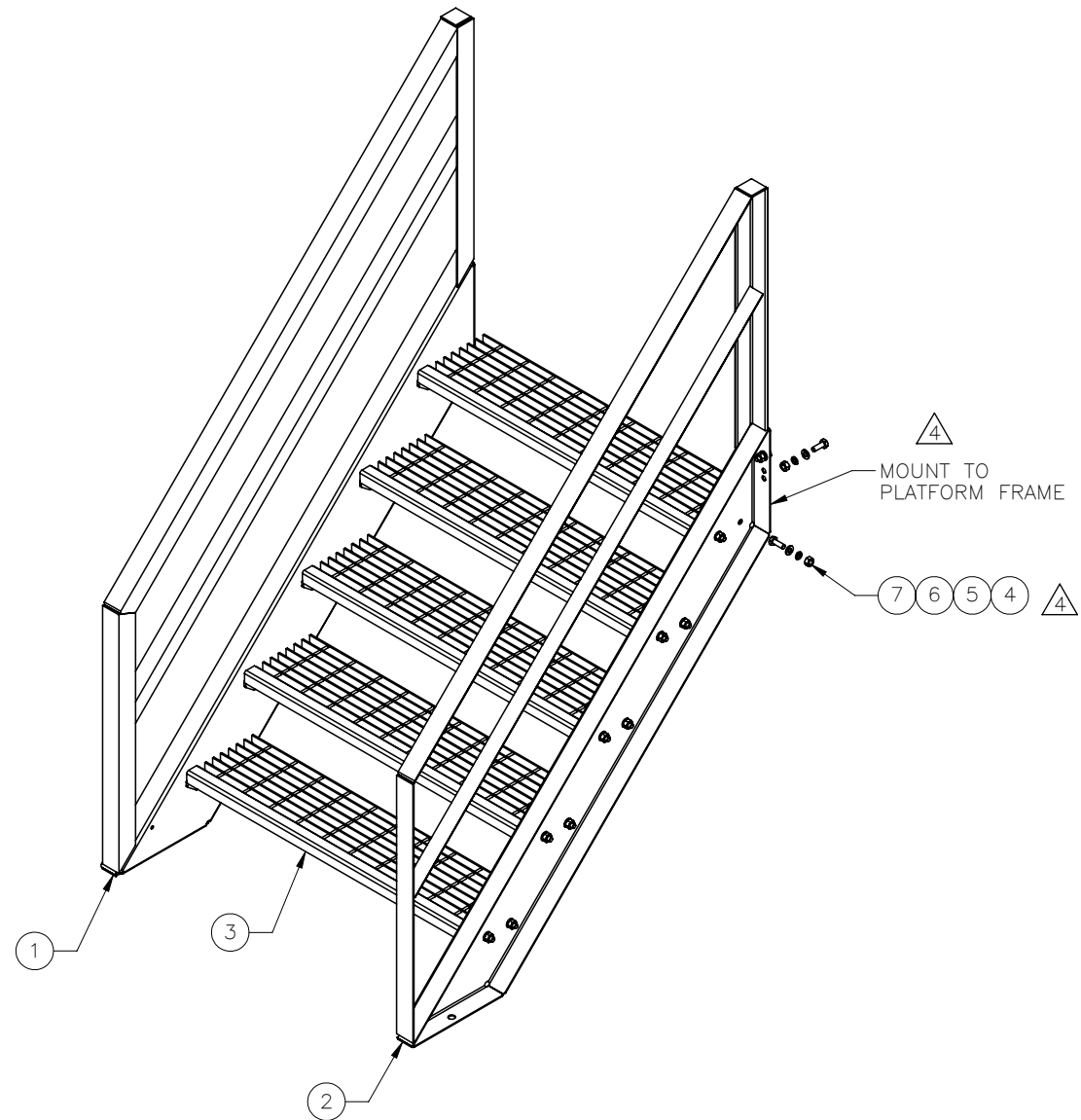
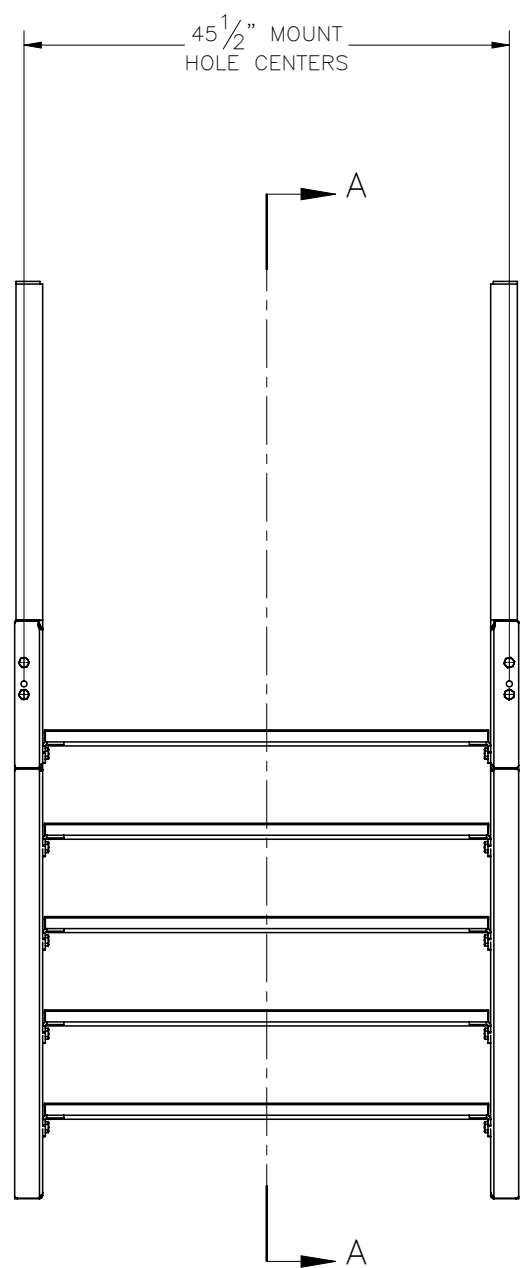

| ITEM NO. | Default QTY REQD | PART NUMBER | DESCRIPTION | LENGTH | WEIGHT |
|----------|------------------|--------------|---|-----------|--------|
| 1 | 1 | W-001-987 | LEFT SIDE STAIR WELDMENT | 98 11/16" | 105.8 |
| 2 | 1 | W-001-988 | RIGHT SIDE STAIR WELDMENT | 98 11/16" | 105.8 |
| 3 | 5 | W-001-864 | 42" WD, STAIR TREAD WELDMNT | | 29.82 |
| 4 | 24 | 002-OBG-0010 | HHB, .500-13 X 1.50 LG., PT X 1.00, A325, HDG | 1.50 | 0.14 |
| 5 | 24 | 002-OFW-G002 | FW, .50, F436, HDG | | 0.02 |
| 6 | 24 | 002-OLW-G002 | WASHER, SPLIT LOCK, .500", GALV | | 0.01 |
| 7 | 24 | 002-ONG-0010 | NUT, HEX, .500-13UNC, GR 2H, GALV | | 0.06 |

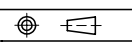
| | | | | | | | | | |
|--|--|---|--|----------------|--|----------|--|--|--|
| SURFACE FINISH <input checked="" type="checkbox"/> UNLESS OTHERWISE SPECIFIED | | UNLESS OTHERWISE SPECIFIED DIMENSIONS ARE IN INCHES | | APPROVALS | | DATE | |  ELECTRO MECHANICAL INDUSTRIES, INC. 11230 NEESEAW DRIVE HOUSTON, TEXAS 77065 1-800-453-0050 | |
| MATERIAL SEE PARTS LIST | | TOLERANCES | | DRAWN RLWjr | | 8/8/2012 | | | |
| THIRD ANGLE PROJECTION  | | FRACTIONS ± 1/16 | | CHECKER CS | | 8/8/2012 | | TITLE: 5 TREAD STAIR ASSY (42" WIDE) | |
| NEXT ASSY | | ANGLES ± .25° | | ENGINEER CS | | 8/8/2012 | | | |
| USED ON | | HOLES: DRILLED OR PUNCHED ± 1/32 | | PRODUCTION JKS | | 8/8/2012 | | SIZE B DRAWING NO. 450-000-0133 REV 4 | |
| APPLICATIONS | | BURNED ± 1/32 | | | | | | SCALE: 1:25 WEIGHT: 366.5 lbs. SHEET 1 OF 1 | |