

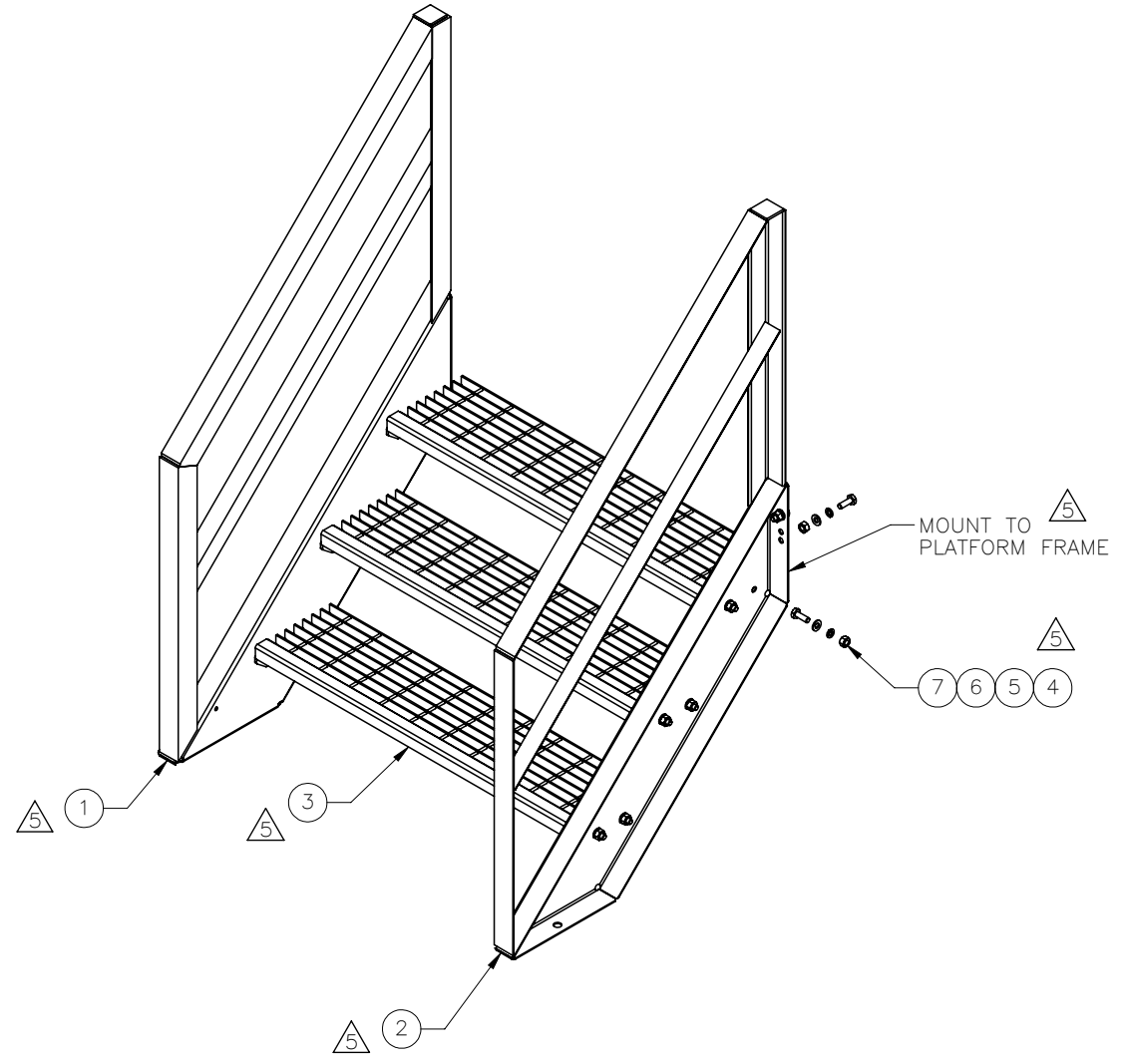

THE INFORMATION CONTAINED IN THIS DRAWING IS THE SOLE PROPERTY OF ELECTRO MECHANICAL INDUSTRIES, INC. ANY REPRODUCTION IN PART OR WHOLE WITHOUT THE WRITTEN PERMISSION OF ELECTRO MECHANICAL IND., IS PROHIBITED.

REVISIONS					
REV.	DCN #	DESCRIPTION	DATE	BY	APPROVED
5	01092	002-0BG-0026 TO 002-0BG-0010, W-001-985 AND W-001-986 UPDATED TO CONSOLIDATE WELDS. ADDED SECTION A-A, W-001-864 UPDATED TO LATEST, DIM'S ADDED FOR CONSISTANCY/CLARITY	10/20/21	JTR	JPB

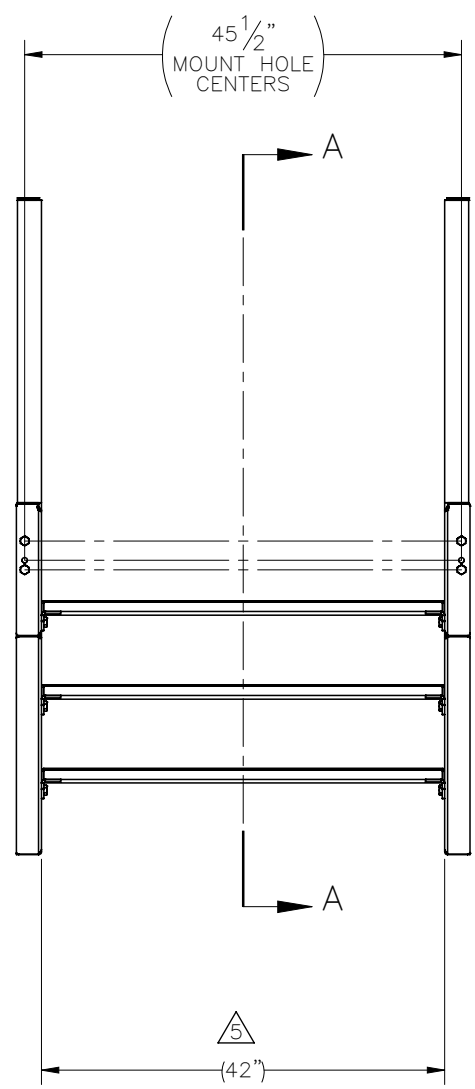
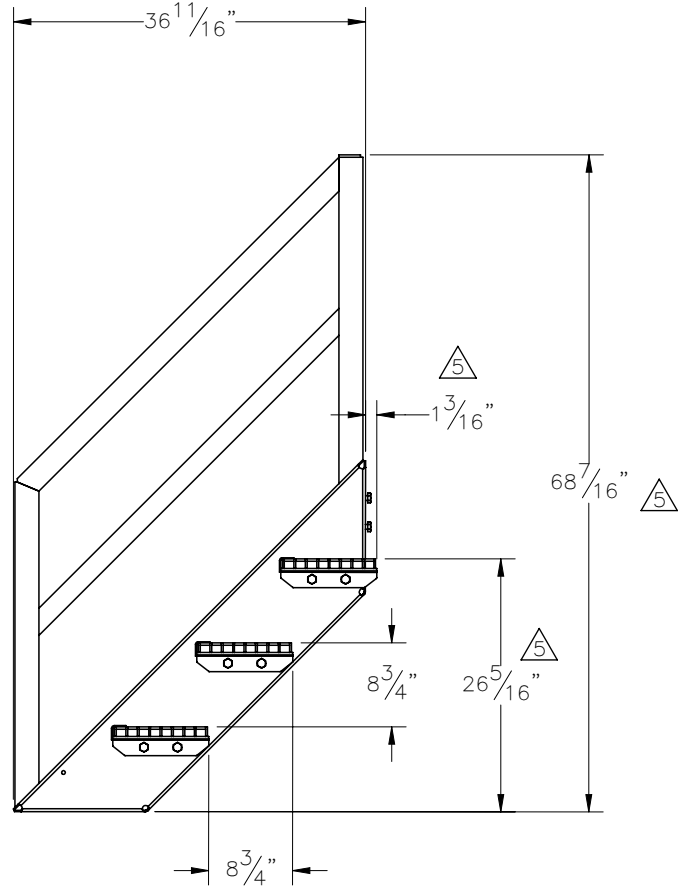

ITEM NO.	QTY REQD	PART NUMBER	DESCRIPTION	LENGTH	WEIGHT
1	1	W-001-985	LEFT SIDE STAIR WELDMENT	68 5/8"	76.9
2	1	W-001-986	RIGHT SIDE STAIR WELDMENT	68 5/8"	76.9
3	3	W-001-864	42" WD, STAIR TREAD WELDMNT		29.82
4	16	002-0BG-0010	HHB, .500-13 X 1.50 LG., PT X 1.00, A325, HDG	1.50	0.14
5	16	002-0FW-G002	FW, .50, F436, HDG		0.02
6	16	002-0LW-G002	WASHER, SPLIT LOCK, .500", GALV		0.01
7	16	002-0NG-0010	NUT, HEX, .500-13UNC, GR 2H, GALV		0.06

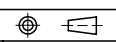
SURFACE FINISH <input checked="" type="checkbox"/> UNLESS OTHERWISE SPECIFIED		UNLESS OTHERWISE SPECIFIED DIMENSIONS ARE IN INCHES		APPROVALS		DATE		 ELECTRO MECHANICAL INDUSTRIES, INC. 11230 NEESEAW DRIVE HOUSTON, TEXAS 77065 1-800-453-0050	
MATERIAL SEE PARTS LIST		TOLERANCES		DRAWN CS		10/20/2011			
THIRD ANGLE PROJECTION 		FRACTIONS ± 1/16		CHECKER LC		1/24/2012		TITLE: <b>3 TREAD STAIR ASSY (42" WIDE)</b>	
NEXT ASSY USED ON		ANGLES ± .25°		ENGINEER CS		1/25/2012			
APPLICATIONS		HOLES: DRILLED OR PUNCHED ± 1/32		PRODUCTION JKS		1/25/2012		SIZE B DRAWING NO. 450-000-0123 REV 5	
		BURNED ± 1/32						SCALE: 1:20 WEIGHT: 247.2 lbs. SHEET 1 OF 1	