

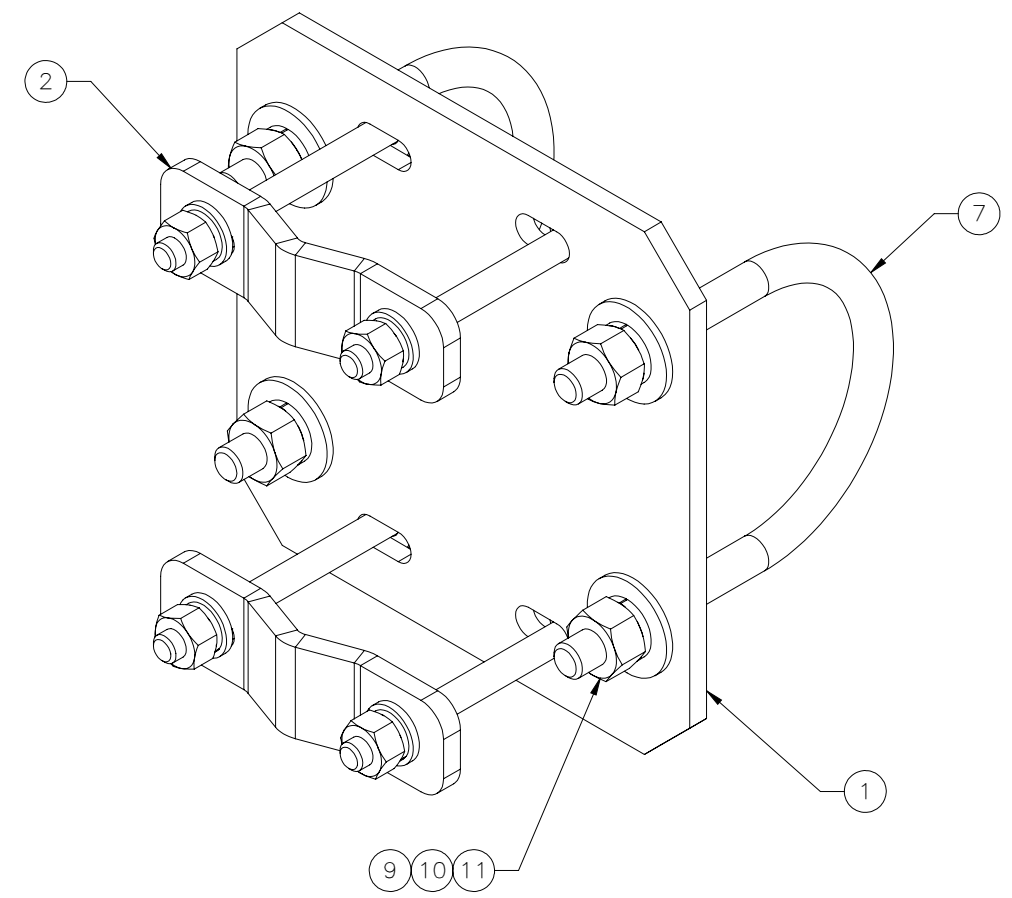

THE INFORMATION CONTAINED IN THIS DRAWING IS THE SOLE PROPERTY OF ELECTRO MECHANICAL INDUSTRIES, INC. ANY REPRODUCTION IN PART OR WHOLE WITHOUT THE WRITTEN PERMISSION OF ELECTRO MECHANICAL IND., IS PROHIBITED.

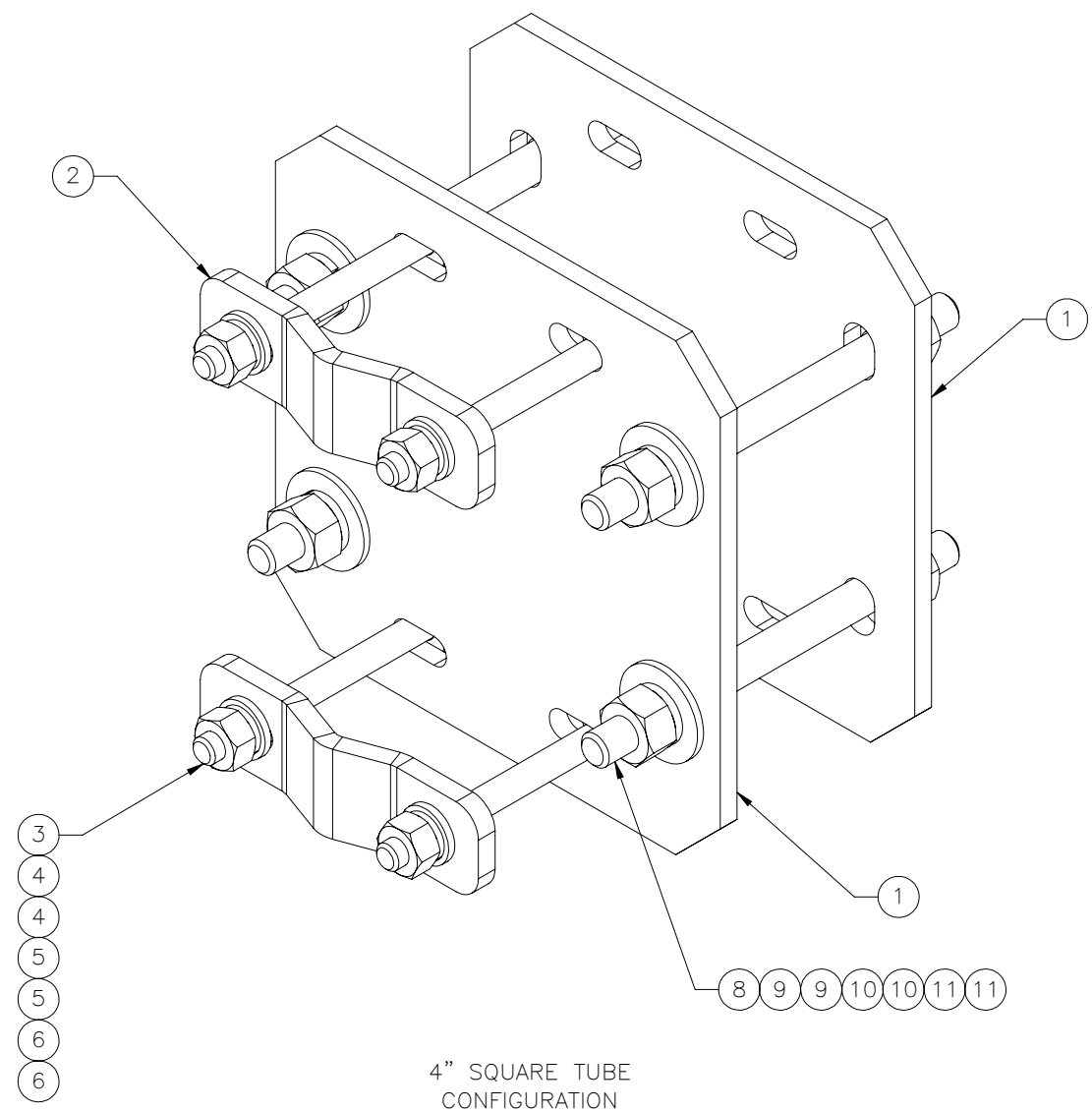
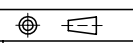

ITEM NO.	QTY REQD	PART NUMBER	DESCRIPTION	LENGTH	WEIGHT
1	2	P-006-909	CROSSOVER PLATE	10"	9.91
2	2	P-005-873	V-CLAMP, 4" SPC		1.06
3	4	002-0AT-HA01	AT, .500-13 X 6.00, GALV, GR B7	6"	0.33
4	8	002-0FW-G002	WASHER, FLAT, .500, GALV, F436		0.03
5	8	002-0LW-G002	WASHER, SPLIT LOCK, .500, GALV		0.014
6	8	002-0NG-0010	NUT, HEX, .500-13, GALV, GR 2H		0.06
7	2	002-00U-G056	U-BOLT, .625-11 X 4.625 ID X 6.500 H X 2.75 TL, GALV		1.45
8	4	002-0AT-H052	AT, .625-11 X 8.0, GALV, GR B7	8"	0.70
9	8	002-0FW-G017	WASHER, FLAT, .625, GALV, USS		0.08
10	8	002-0LW-G004	WASHER, SPLIT LOCK, .625, GALV		0.03
11	8	002-0NG-0004	NUT, HEX, .625-11, GALV, GR 2H		0.115

SURFACE FINISH <input checked="" type="checkbox"/> UNLESS OTHERWISE SPECIFIED		UNLESS OTHERWISE SPECIFIED DIMENSIONS ARE IN INCHES		APPROVALS		DATE		 ELECTRO MECHANICAL INDUSTRIES, INC. 11230 NEESESHAW DRIVE HOUSTON, TEXAS 77065 1-800-453-0050	
MATERIAL SEE PARTS LIST		TOLERANCES		DRAWN C. SANCHEZ		8/25/2023			
THIRD ANGLE PROJECTION 		.0 ±.06 .00 ±.015 .000 ±.005		CHECKER J. ROACH		8/25/2023		TITLE: SINGLE CROSSOVER KIT, 2.38-3.5 X 4.50 W U-BOLTS	
NEXT ASSY		FRACTIONS ± 1/16 ANGLES ± .25°		ENGINEER J. Breen		8/28/2023			
USED ON		HOLES: DRILLED OR PUNCHED ± 1/32		PRODUCTION J. KERNER		8/28/2023		SIZE B DRAWING NO. 1012-0000-0112 REV 0	
APPLICATIONS		BURNED ± 1/32		SCALE: 1:3		WEIGHT: 17.96 lbs.		SHEET 1 OF 1	