

THE INFORMATION CONTAINED IN THIS DRAWING IS THE SOLE PROPERTY OF ELECTRO MECHANICAL INDUSTRIES, INC. ANY REPRODUCTION IN PART OR WHOLE WITHOUT THE WRITTEN PERMISSION OF ELECTRO MECHANICAL IND., IS PROHIBITED.

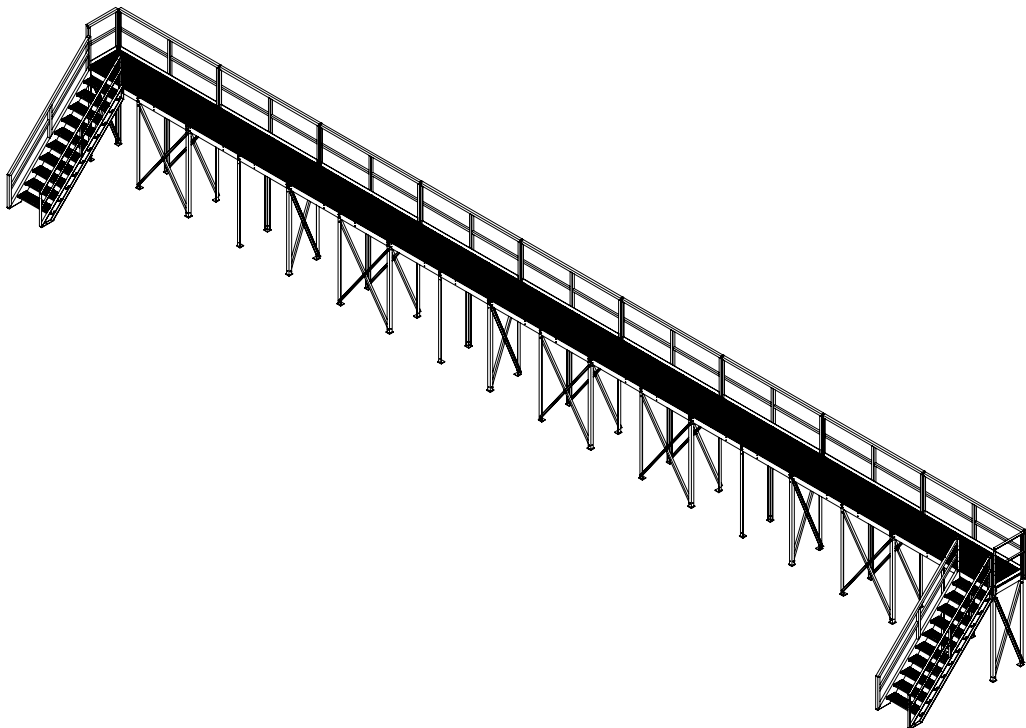

ITEM NO.	QTY REQD	PART NUMBER	DESCRIPTION	LENGTH	WEIGHT
1	9	W-002-795	CATWALK FRAME WELDMENT		248.78
2	38	W-002-796	CATWALK LEG WELDMENT		57.54
3	9	1004-T001-1190	ANGLE GUARDRAIL, 119	119"	149.00
4	2	1004-T001-0354	ANGLE GUARDRAIL, 35.5	35 1/2"	60.19
5	9	T010-0357-1194	GRATING PANEL, 1" THK SMOOTH, 31 BAR, 35.8125 WIDTH	119 1/2"	208.18
6	36	000-MSG-0008	GRATING CLIP, 1", GALV.		0.20
7	5	A-000-665	X BRACE ASSEMBLY		49.0
8	10	A-000-666	X BRACE ASSEMBLY		55.4
9	2	450-000-0172	10 TREAD STAIR ASSY (36" WIDE)		832.6
10	172	002-0BG-0014	BOLT, HH, .500-13 X 2.00, GALV, A325, PT X 1.00	2"	0.1697
11	344	002-0FW-G002	WASHER, FLAT, .500, GALV, F436		0.03
12	172	002-0LW-G002	WASHER, SPLIT LOCK, .500, GALV		0.014
13	172	002-0NG-0010	NUT, HEX, .500-13, GALV, GR 2H		0.06

SURFACE FINISH <input checked="" type="checkbox"/> UNLESS OTHERWISE SPECIFIED		UNLESS OTHERWISE SPECIFIED DIMENSIONS ARE IN INCHES		APPROVALS		DATE		<b>ELECTRO MECHANICAL INDUSTRIES, INC.</b> 11230 NEESESHAW DRIVE HOUSTON, TEXAS 77065 1-800-453-0050	
MATERIAL SEE PARTS LIST		TOLERANCES		DRAWN J. ROACH		1/25/2024			
THIRD ANGLE PROJECTION		FRACTIONS ± 1/16		CHECKER J. Breen		1/30/2024		TITLE: <h2 style="text-align: center;">89' ELEVATED CATWALK</h2>	
NEXT ASSY USED ON		ANGLES ± .25°		ENGINEER J. Breen		1/30/2024			
APPLICATIONS		HOLES: DRILLED OR PUNCHED ± 1/32		PRODUCTION J. KERNER		1/30/2024		SIZE <b>B</b> DRAWING NO. 1006-0020-0028 REV 0	
		BURNED ± 1/32						SCALE: 1:192 WEIGHT: 10283.74 lbs. SHEET 1 OF 2	

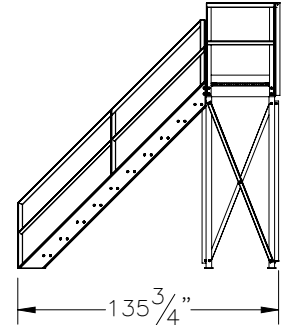
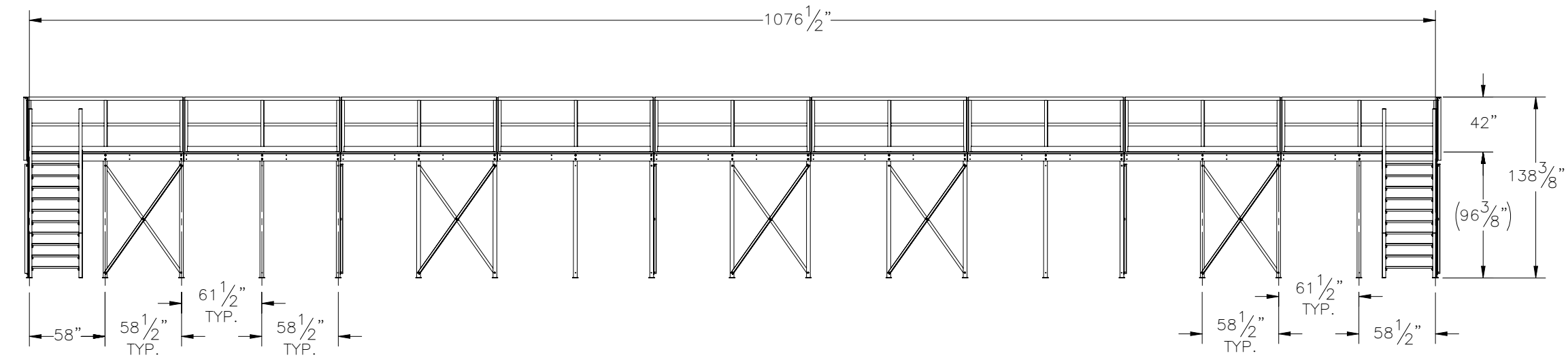
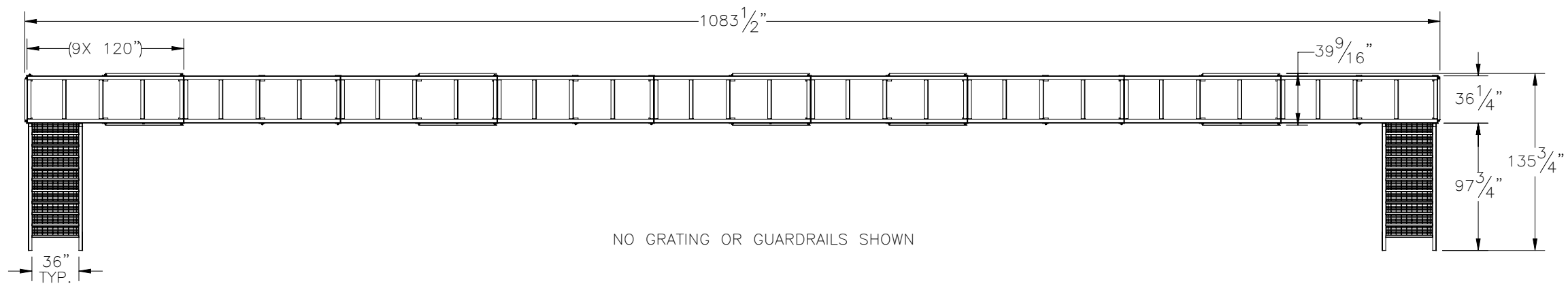
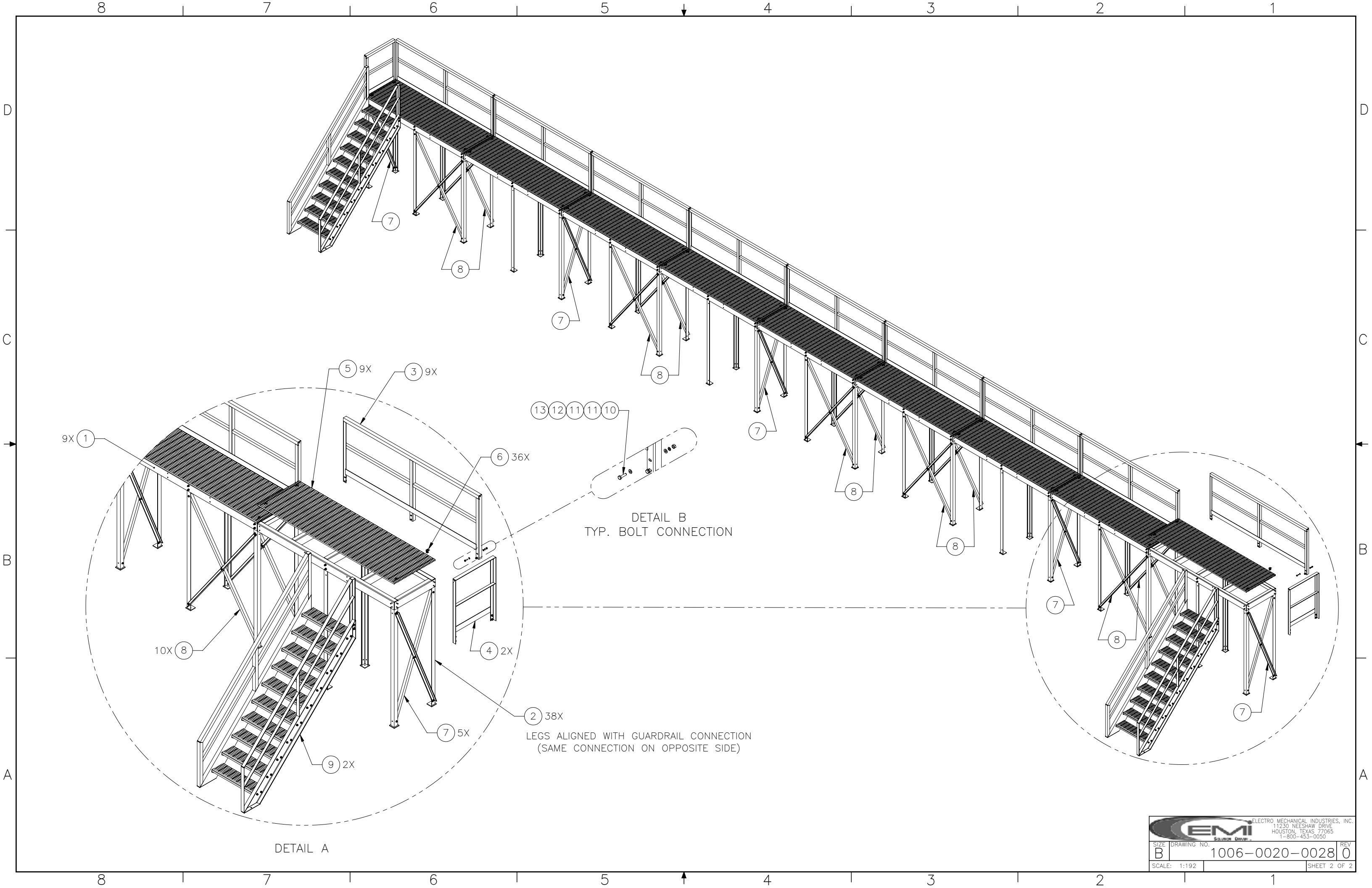

DETAIL A

DETAIL B  
TYP. BOLT CONNECTION

LEGS ALIGNED WITH GUARDRAIL CONNECTION  
(SAME CONNECTION ON OPPOSITE SIDE)

 ELECTRO MECHANICAL INDUSTRIES, INC. 11230 NEESHAW DRIVE HOUSTON, TEXAS 77065 1-800-453-0050		REV
		0
SIZE	DRAWING NO.	REV
B	1006-0020-0028	0
SCALE: 1:192	SHEET 2 OF 2	