

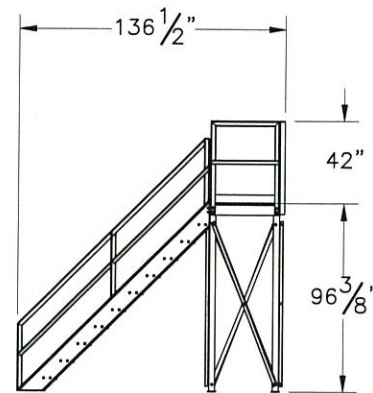

THE INFORMATION CONTAINED IN THIS DRAWING IS THE SOLE PROPERTY OF ELECTRO MECHANICAL INDUSTRIES, INC. ANY REPRODUCTION IN PART OR WHOLE WITHOUT THE WRITTEN PERMISSION OF ELECTRO MECHANICAL IND., IS PROHIBITED.

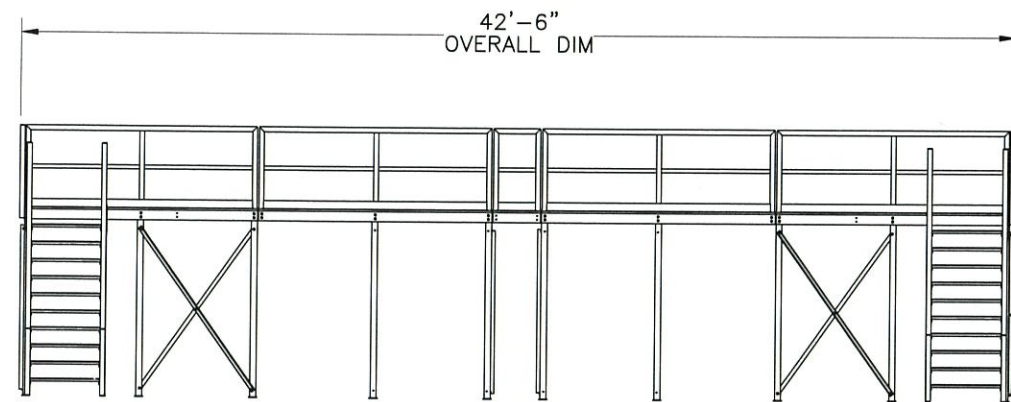
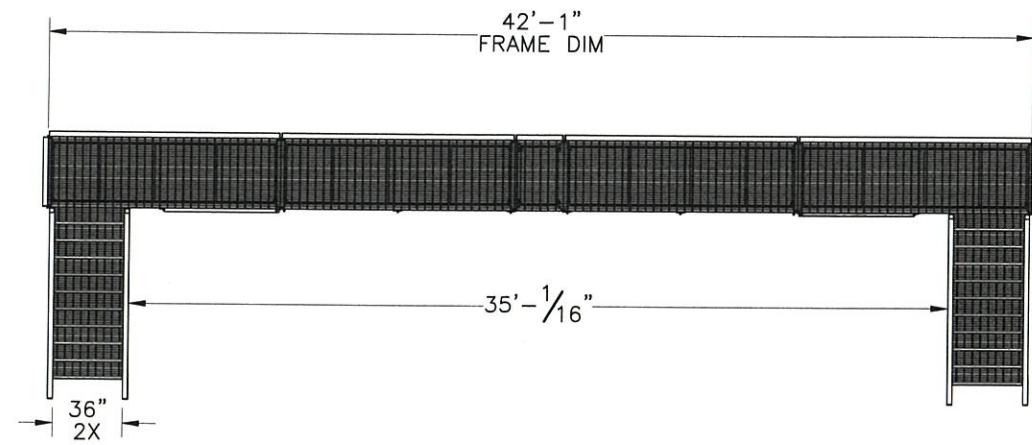

ITEM NO.	QTY	PART NUMBER	DESCRIPTION	LENGTH	WEIGHT
1	2	W-000-700	CATWALK FRAME WELDMENT 36.25" X 120"	120"	223.82
2	2	W-000-435	CATWALK FRAME WELDMENT 36.25" X 120"	120"	223.96
3	1	W-001-174	CATWALK FRAME WELDMENT 36.25" X 25"	25"	63.98
4	2	450-000-0172	7' STAIR ASSEMBLY (36" WIDE)		824.3
5	20	W-000-623	CATWALK LEG WELDMENT, 96"		57.54
6	4	A-000-135	X BRACE ASSEMBLY		48.8
7	4	A-000-136	X BRACE ASSEMBLY		55.2
8	4	450-000-0601-1190	HANDRAIL, 119"	119"	149.2
9	2	450-000-0601-0354	HANDRAIL, 35-1/2"		60.2
10	1	450-000-0601-0240	HANDRAIL, 24"		50.1
11	4	450-000-0703-1196	GRATING PANEL, 36" X 119-3/4"		208.67
12	1	450-000-0703-0246	GRATING PANEL, 36" X 24-3/4"	24 3/4"	43.04
13	20	000-MSG-0008	GRATING CLIP, 1", GALV.		0.21
14	96	002-0BG-0049	BOLT, HX HD, .500-13UNC, 2.00 LG, GR 5, GALV		0.15
15	96	002-0NG-0010	NUT, HEX, .500-13UNC, GR DH, GALV		0.06
16	96	002-0LW-G002	WASHER, SPLIT LOCK, .500", GALV		0.01
17	192	002-0FW-G002	WASHER, FLAT, .500", F436, GALV		0.02

SURFACE FINISH <input checked="" type="checkbox"/> UNLESS OTHERWISE SPECIFIED		UNLESS OTHERWISE SPECIFIED DIMENSIONS ARE IN INCHES		APPROVALS	DATE	 ELECTRO MECHANICAL INDUSTRIES, INC. 11230 NEEDHAM DRIVE HOUSTON, TEXAS 77065 1-800-453-0050
MATERIAL	TOLERANCES .00 ± .06 .000 ± .01 ± .005	THIRD ANGLE PROJECTION 	FRACTIONS ± 1/16	DRAWN J. CRITELLI 11.20.18	11/29/18	
NEXT ASSY	USED ON	DRILLED OR PUNCHED +1/32	ANGLES ± .25°	ENGINEER/DISIGNER J. Green 11/20/18	PRODUCTION JKS 11-26-18	SIZE B DRAWING NO. 1006-0020-0021 SCALE: 1:96 WEIGHT: 5083.4113 SHEET 1 OF 4
APPLICATIONS		BURNED ± 1/32				

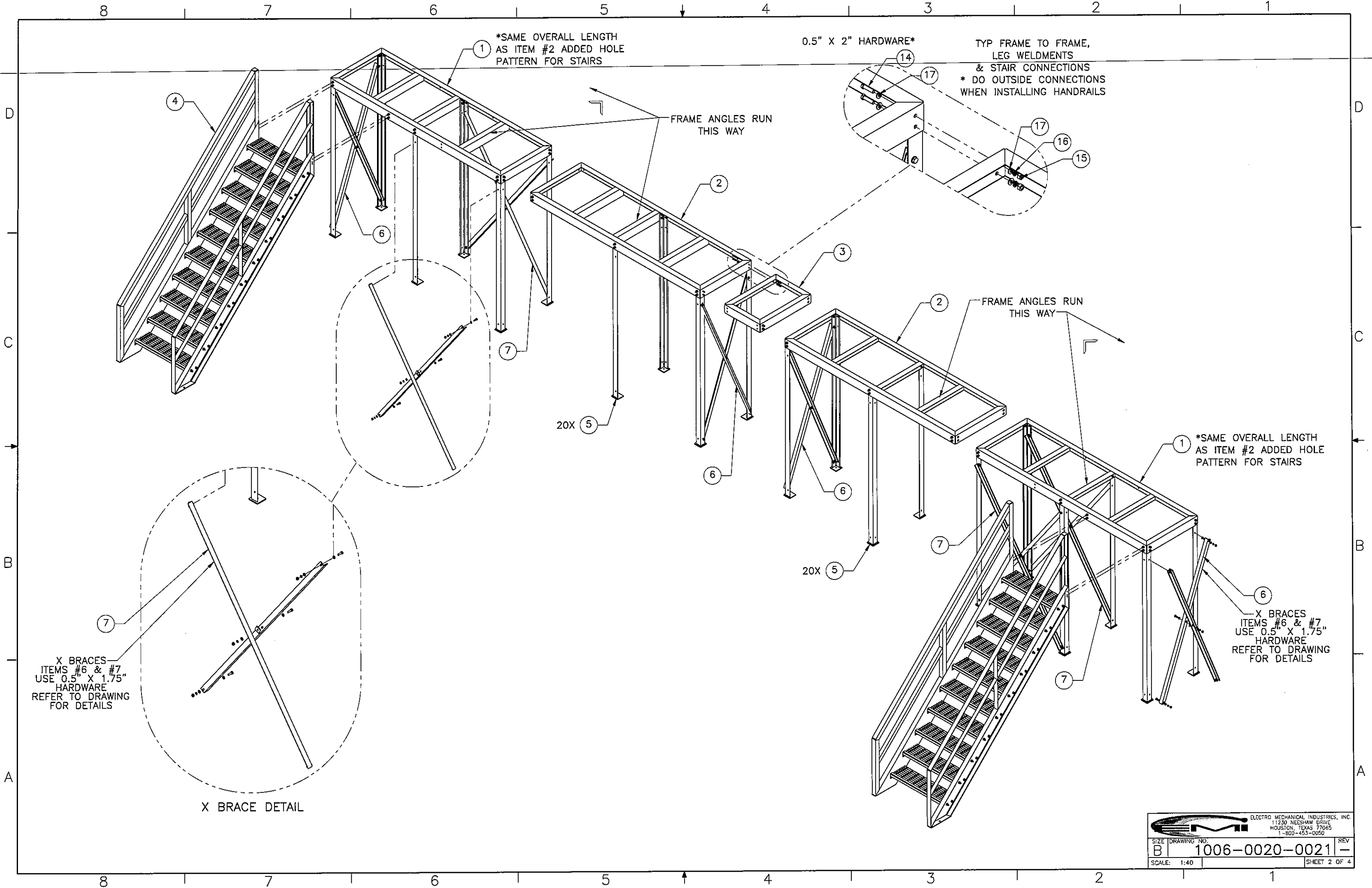

X BRACES
ITEMS #6 & #7
USE 0.5" X 1.75"
HARDWARE
REFER TO DRAWING
FOR DETAILS

X BRACE DETAIL

		ELECTRO MECHANICAL INDUSTRIES, INC. 11230 NEESHAW DRIVE HOUSTON, TEXAS 77065 1-800-453-0050
SIZE B	DRAWING NO. 1006-0020-0021	REV —
SCALE: 1:40	SHEET 2 OF 4	

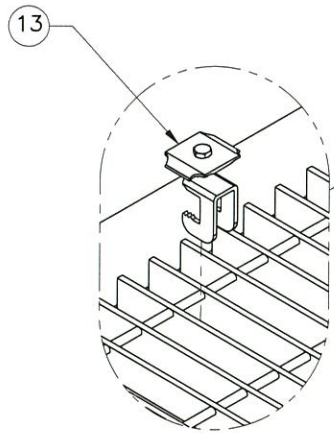
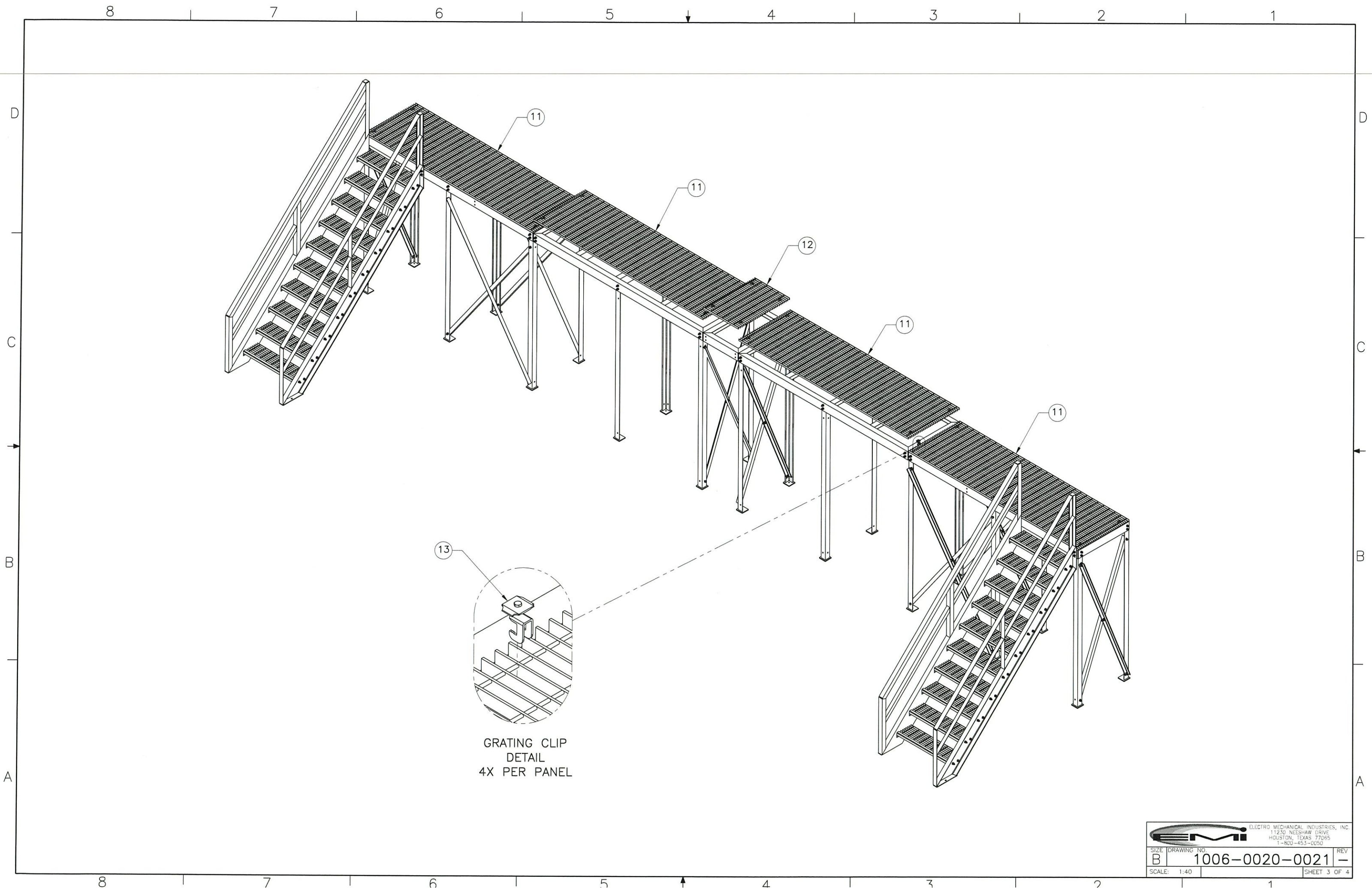

GRATING CLIP
DETAIL
4X PER PANEL

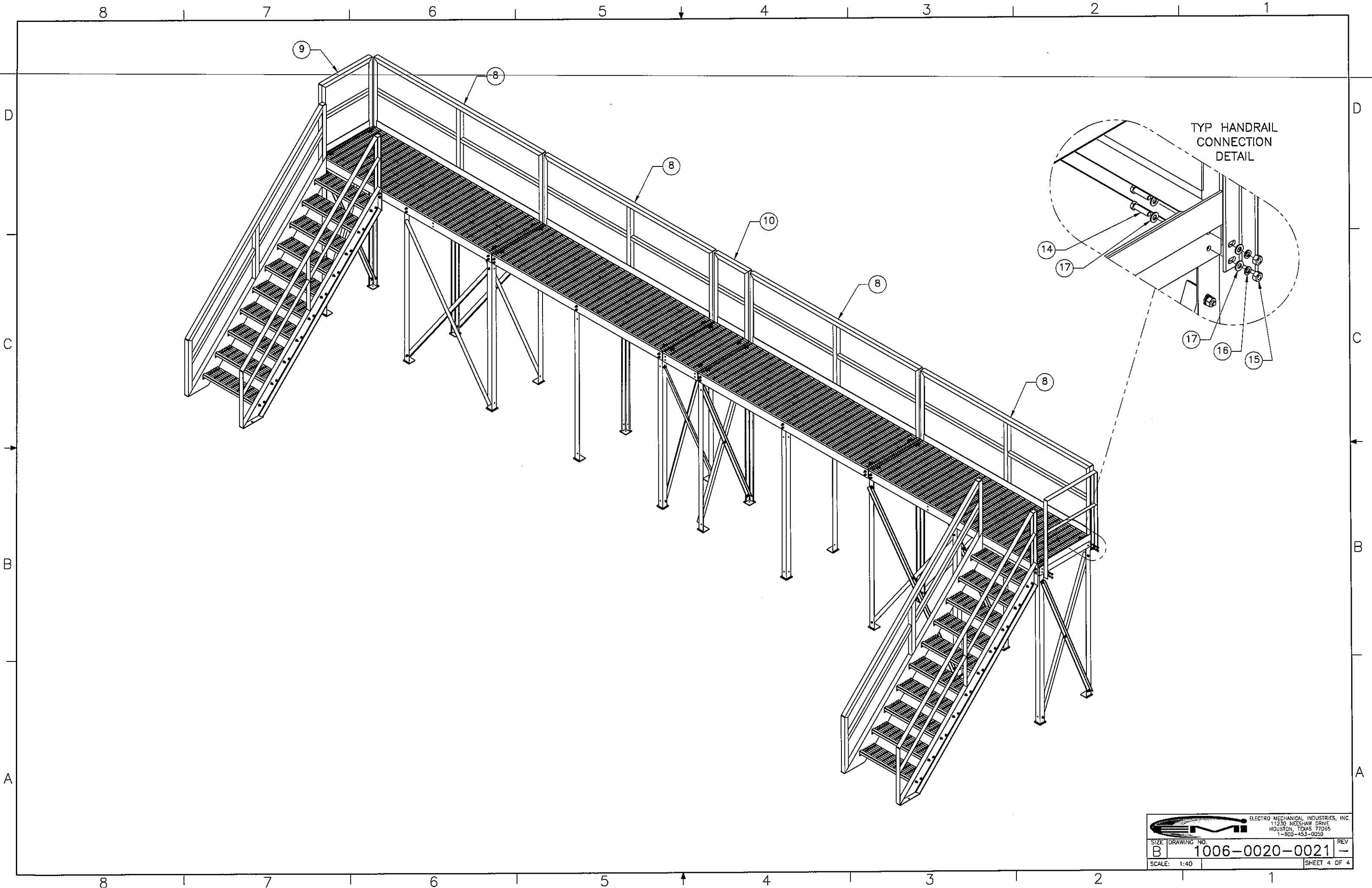

TYP HANDRAIL
CONNECTION
DETAIL

		ELECTRO MECHANICAL INDUSTRIES, INC. 11230 NEESHAW DRIVE HOUSTON, TEXAS 77065 1-800-453-0050	
SIZE	DRAWING NO.	REV	
B	1006-0020-0021	-	
SCALE: 1:40	SHEET 4 OF 4		