

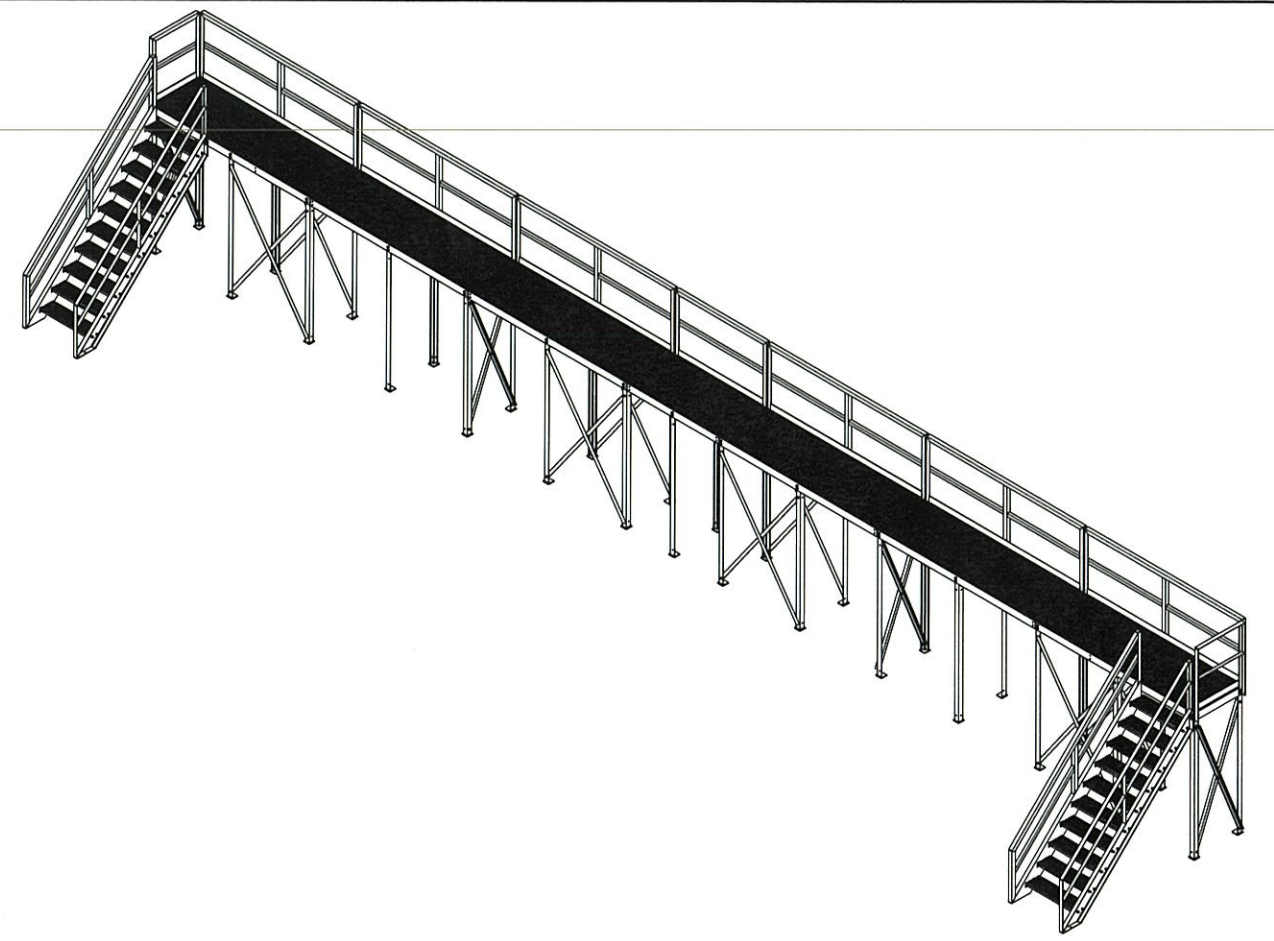

THE INFORMATION CONTAINED IN THIS DRAWING IS THE SOLE PROPERTY OF ELECTRO MECHANICAL INDUSTRIES, INC. ANY REPRODUCTION IN PART OR WHOLE WITHOUT THE WRITTEN PERMISSION OF ELECTRO MECHANICAL IND., IS PROHIBITED.

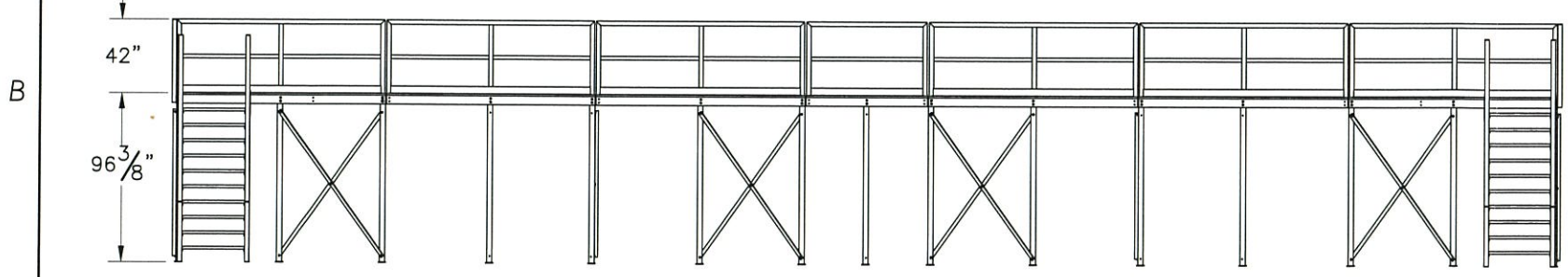
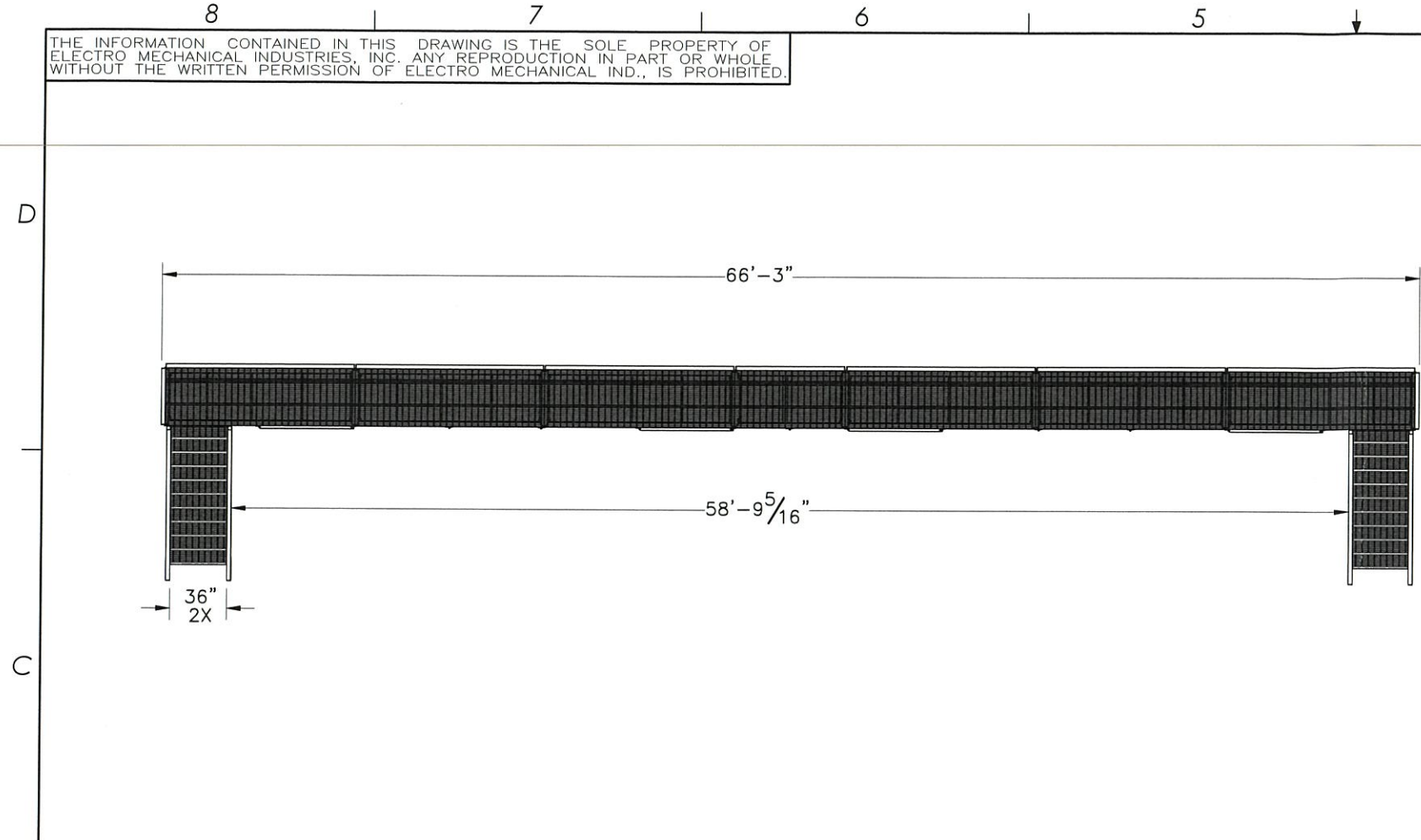

ITEM NO.	QTY	PART NUMBER	DESCRIPTION	LENGTH	WEIGHT
1	4	W-000-435	CATWALK FRAME WELDMENT 36.25" X 120"	120"	223.96
2	2	W-000-700	CATWALK FRAME WELDMENT 36.25" X 120"	120"	223.82
3	1	W-001-040	CATWALK FRAME WELDMENT 36.25" X 70"	70"	131.89
4	2	450-000-0172	7' STAIR ASSEMBLY (36" WIDE)		824.3
5	30	W-000-623	CATWALK LEG WELDMENT, 96"		57.54
6	4	A-000-135	X BRACE ASSEMBLY		48.8
7	8	A-000-136	X BRACE ASSEMBLY		55.2
8	1	450-000-0703-0696	GRATING PANEL, 36" X 69-3/4"	69 3/4"	122.12
9	6	450-000-0703-1196	GRATING PANEL, 36" X 119-3/4"		208.67
10	28	000-MSG-0008	GRATING CLIP, 1", GALV.		0.21
11	6	450-000-0601-1190	HANDRAIL, 119"	119"	149.2
12	1	450-000-0601-0690	HANDRAIL, 69"		89.8
13	2	450-000-0601-0354	HANDRAIL, 35-1/2"		60.2
14	136	002-0BG-0049	BOLT, HX HD, .500-13UNC, 2.00 LG, GR 5, GALV		0.15
15	136	002-0NG-0010	NUT, HEX, .500-13UNC, GR DH, GALV		0.06
16	136	002-0LW-G002	WASHER, SPLIT LOCK, .500", GALV		0.01
17	272	002-0FW-G002	WASHER, FLAT, .500", F436, GALV		0.02

SURFACE FINISH <input checked="" type="checkbox"/> UNLESS OTHERWISE SPECIFIED		UNLESS OTHERWISE SPECIFIED DIMENSIONS ARE IN INCHES		APPROVALS	DATE	 ELECTRO MECHANICAL INDUSTRIES, INC. 11230 NEESEHAW DRIVE HOUSTON, TEXAS 77065 1-800-453-0050
MATERIAL	SEE PARTS LIST	TOLERANCES		DRAWN J. CRITELLI	11.15.18	
THIRD ANGLE PROJECTION		FRACTIONS ± 1/16		CHECKED <i>[Signature]</i>	11/15/18	66' 3" ELEVATED CATWALK
NEXT ASSY	USED ON	ANGLES ± .25°		ENGINEER/DESIGNER <i>[Signature]</i>	11/15/18	
APPLICATIONS		HOLES: DRILLED OR PUNCHED ± 1/32		PRODUCTION <i>[Signature]</i>	11-26-18	SIZE B DRAWING NO. 1006-0020-0016 SCALE: 1:100 WEIGHT: 5513.1731 lbs. SHEET 1 OF 4

8

7

6

5

4

3

2

1

TYP FRAME TO FRAME,
LEG WELDMENTS
& STAIR CONNECTIONS
* DO OUTSIDE CONNECTIONS
WHEN INSTALLING HANDRAILS

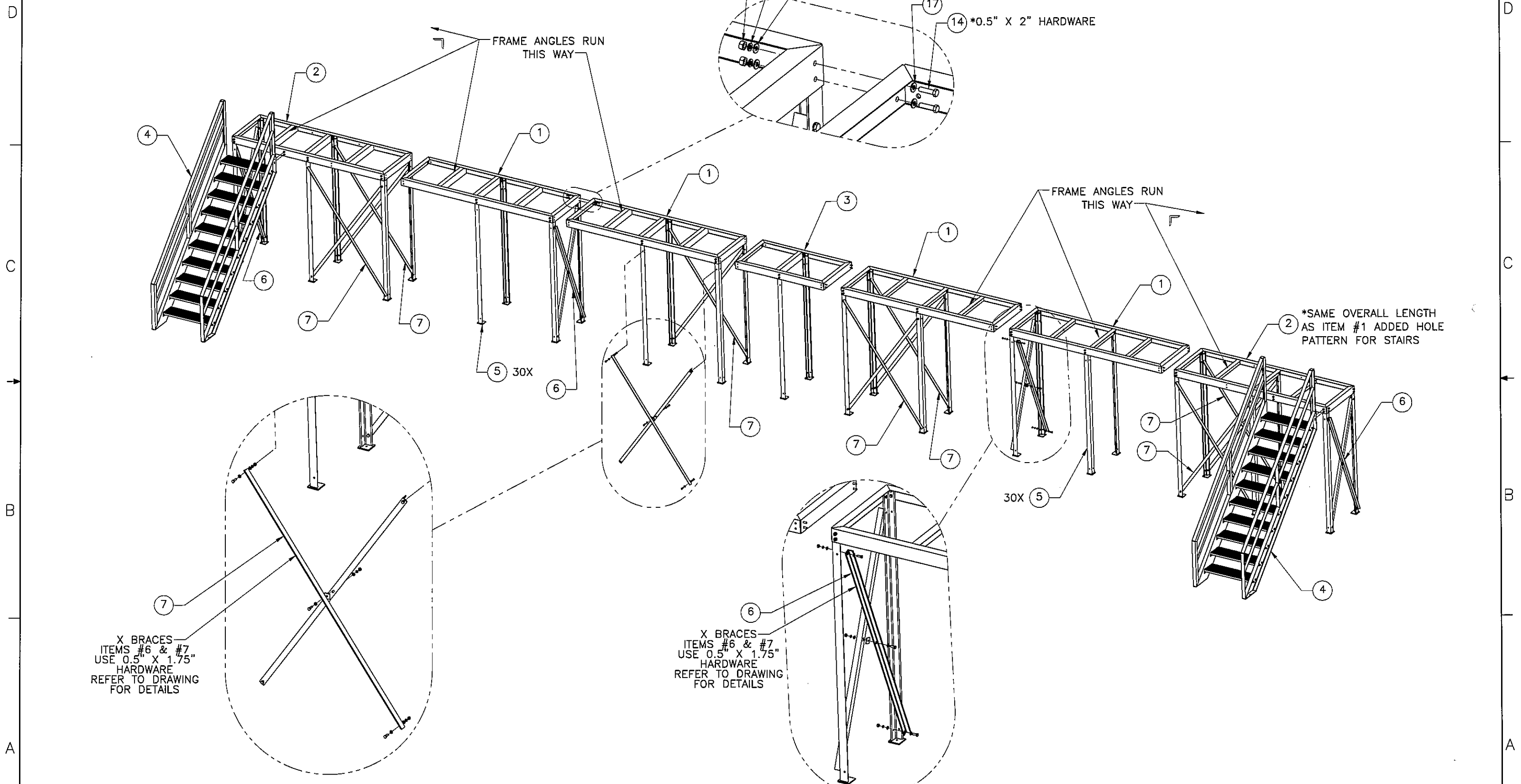

FRAME ANGLES RUN THIS WAY

FRAME ANGLES RUN THIS WAY

*SAME OVERALL LENGTH AS ITEM #1 ADDED HOLE PATTERN FOR STAIRS

X BRACES
ITEMS #6 & #7
USE 0.5" X 1.75"
HARDWARE
REFER TO DRAWING
FOR DETAILS

X BRACES
ITEMS #6 & #7
USE 0.5" X 1.75"
HARDWARE
REFER TO DRAWING
FOR DETAILS

14 *0.5" X 2" HARDWARE

		ELECTRO MECHANICAL INDUSTRIES, INC. 11230 NEESHAW DRIVE HOUSTON, TEXAS 77065 1-800-453-0050	
SIZE	DRAWING NO.	REV	
B	1006-0020-0016		
SCALE: 1:60			SHEET 2 OF 4

8

7

6

5

4

3

2

1

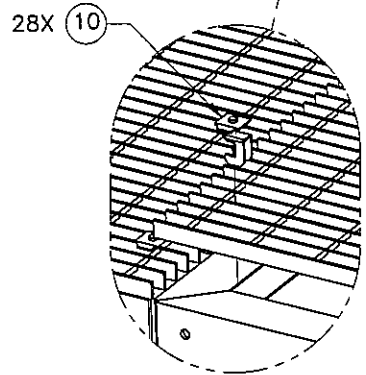
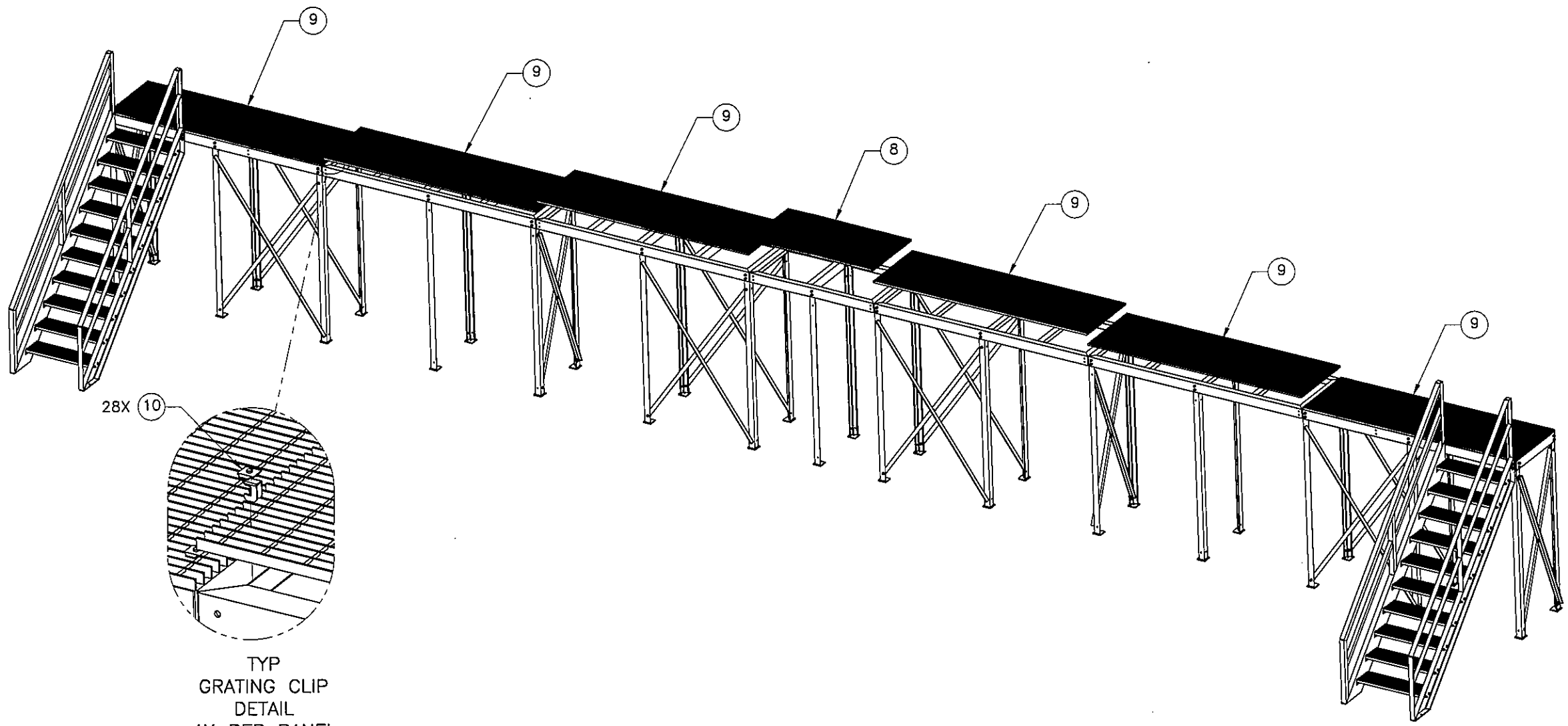

TYP
GRATING CLIP
DETAIL
4X PER PANEL

 ELECTRO MECHANICAL INDUSTRIES, INC. 11230 NEESAW DRIVE HOUSTON, TEXAS 77065 1-800-453-0050		
SIZE	DRAWING NO.	REV
B	1006-0020-0016	-
SCALE: 1:60	SHEET 3 OF 4	

8 7 6 5 4 3 2 1

D

D

C

C

B

B

A

A

TYP
HANDRAIL CONNECTION
DETAIL

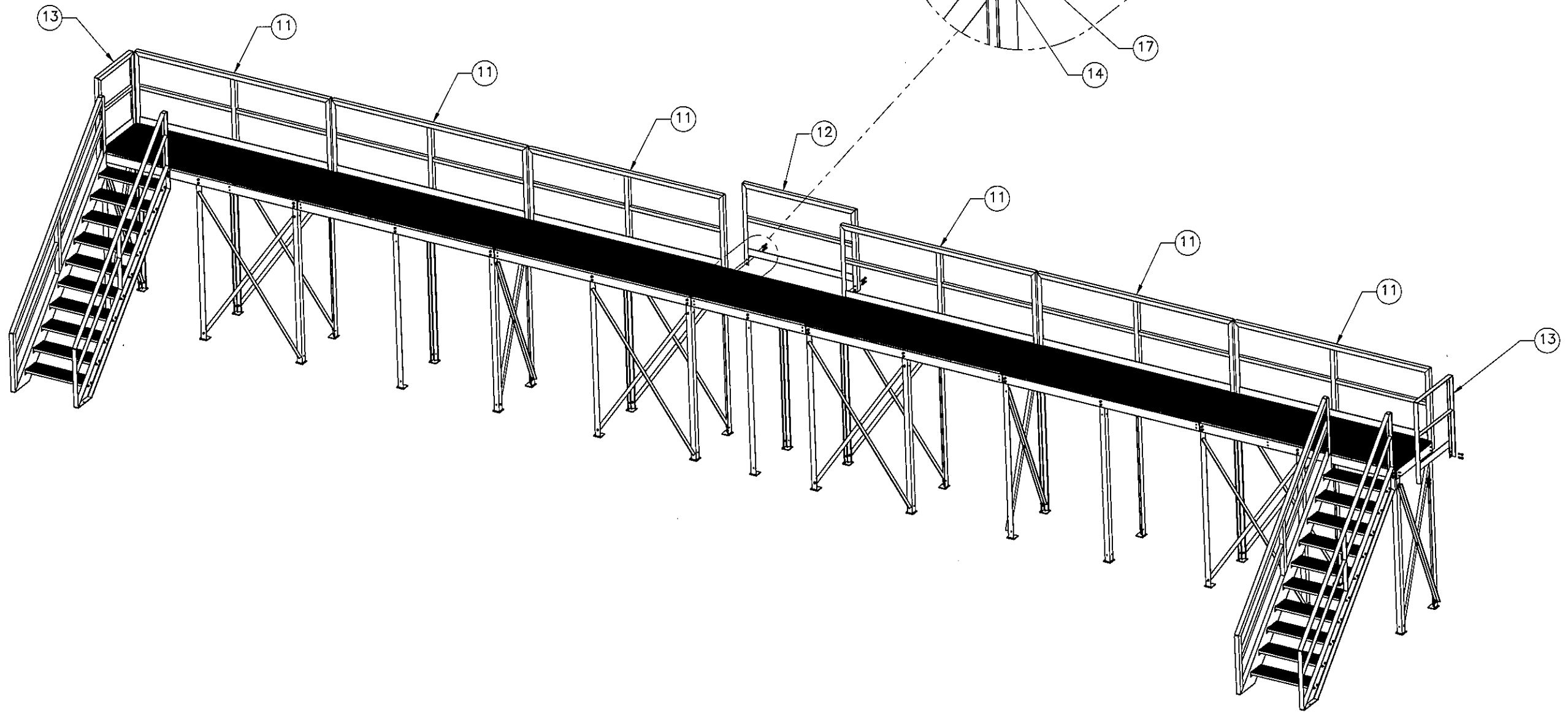
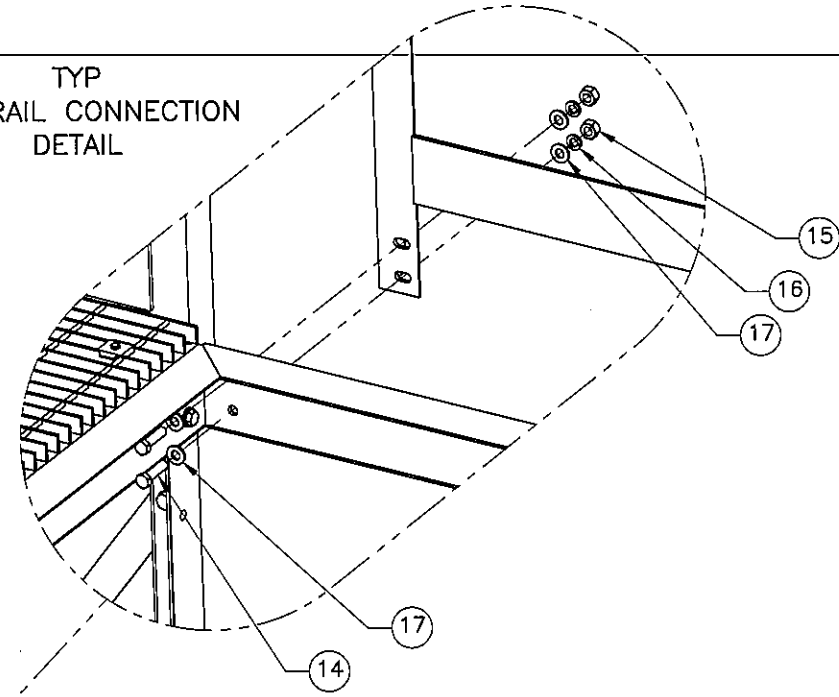

		ELECTRO MECHANICAL INDUSTRIES, INC. 11230 NEESHAW DRIVE HOUSTON, TEXAS 77065 1-800-453-0050	
SIZE	DRAWING NO.	REV	
B	1006-0020-0016	-	-
SCALE: 1:60			SHEET 4 OF 4

8 7 6 5 4 3 2 1