

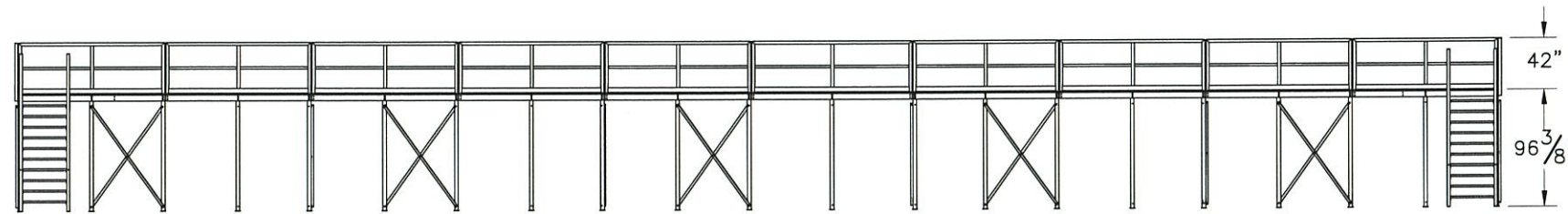

THE INFORMATION CONTAINED IN THIS DRAWING IS THE SOLE PROPERTY OF ELECTRO MECHANICAL INDUSTRIES, INC. ANY REPRODUCTION IN PART OR WHOLE WITHOUT THE WRITTEN PERMISSION OF ELECTRO MECHANICAL IND., IS PROHIBITED.

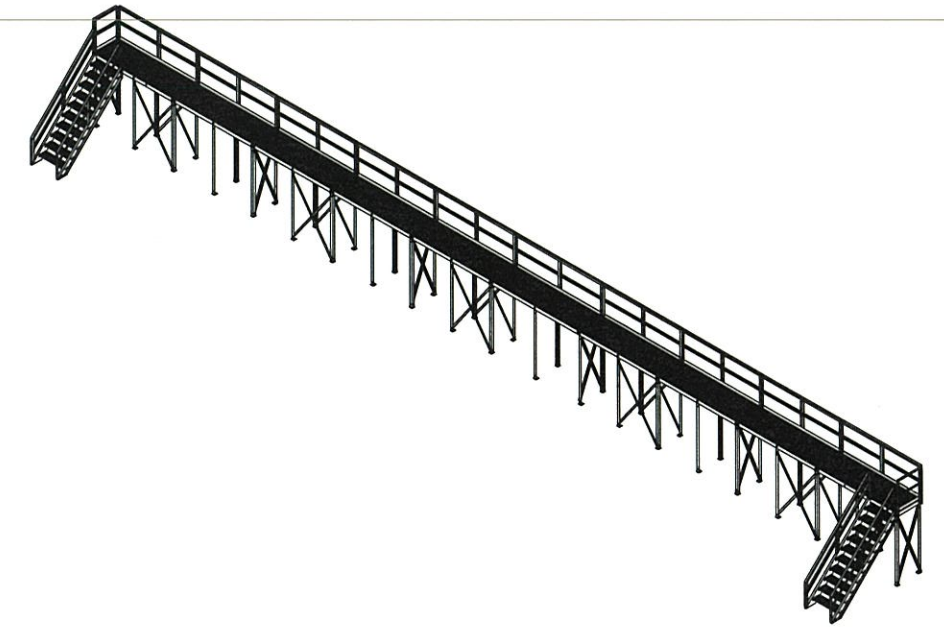
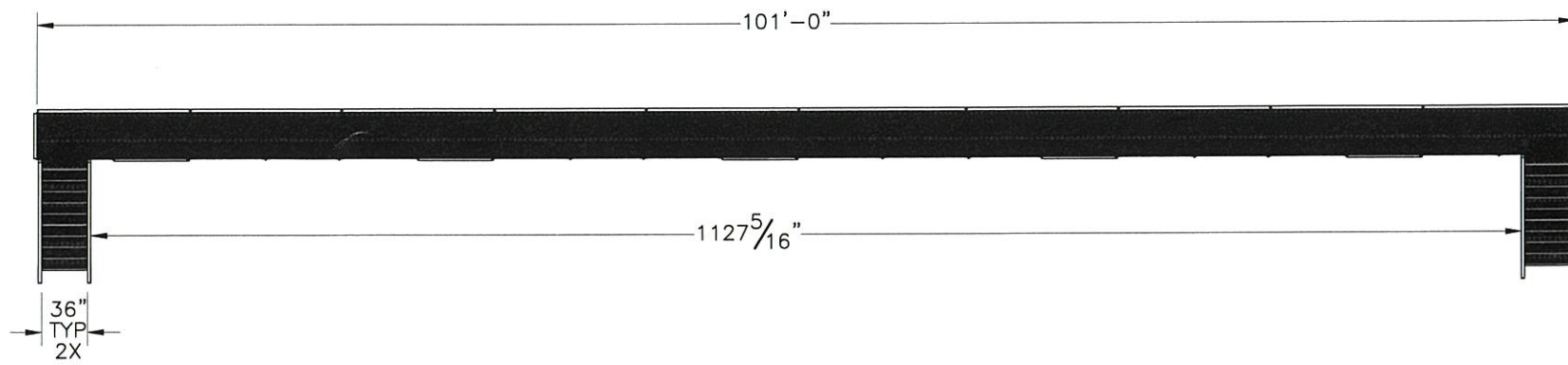

ITEM NO.	QTY	PART NUMBER	DESCRIPTION	WEIGHT
1	2	W-000-700	CATWALK FRAME WELDMENT 36.25" X 120"	223.82
2	7	W-000-435	CATWALK FRAME WELDMENT 36.25" X 120"	223.96
3	1	W-000-967	CATWALK FRAME WELDMENT 36.25" X 132"	237.17
4	2	450-000-0172	7' STAIR ASSEMBLY (36" WIDE)	824.3
5	42	W-000-623	CATWALK LEG WELDMENT, 96"	57.54
6	6	A-000-135	X BRACE ASSEMBLY	48.6
7	10	A-000-136	X BRACE ASSEMBLY	55.2
8	1	450-000-0703-1314	GRATING PANEL, 36" X 131.5"	229.17
9	9	450-000-0703-1196	GRATING PANEL, 36" X 119-3/4"	208.67
10	40	000-MSG-0008	GRATING CLIP, 1", GALV.	0.21
11	1	450-000-0601-1310	HANDRAIL, 131"	159.8
12	9	450-000-0601-1190	HANDRAIL, 119"	149.2
13	2	450-000-0601-0354	HANDRAIL, 35-1/2"	60.2
14	190	002-OBG-0049	BOLT, HX HD, .500-13UNC, 2.00 LG, GR 5, GALV	0.15
15	190	002-ONG-0010	NUT, HEX, .500-13UNC, GR 2H, GALV	0.06
16	190	002-OLW-G002	WASHER, SPLIT LOCK, .500", GALV	0.01
17	380	002-OFW-G002	WASHER, FLAT, .500", F436, GALV	0.02

SURFACE FINISH <input checked="" type="checkbox"/> UNLESS OTHERWISE SPECIFIED		UNLESS OTHERWISE SPECIFIED DIMENSIONS ARE IN INCHES		APPROVALS		DATE		 ELECTRO MECHANICAL INDUSTRIES, INC. 11230 NEESEAW DRIVE HOUSTON, TEXAS 77065 1-800-453-0050	
MATERIAL SEE PARTS LIST		TOLERANCES .00 ± .06 .000 ± .01 ± .005		DRAWN J. CRITELLI		2018-12-05		TITLE: 101' ELEVATED CATWALK	
THIRD ANGLE PROJECTION 		FRACTIONS ± 1/16		CHECKED <i>J. Green</i>		3/7/19			
		ANGLES ± .25°		ENGINEER/DESIGNER <i>J. Green</i>		3/7/19			
		HOLES: DRILLED OR PUNCHED +1/32		PRODUCTION <i>JKS</i>		3-7-19			
NEXT ASSY USED ON		BURNED ±1/32		SIZE B		DRAWING NO. 1006-0020-0002		REV -	
APPLICATIONS				SCALE: 1:140		WEIGHT: 10954.4063 lbs.		SHEET 1 OF 4	

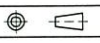
NOTE: INCLUDE 5 EXTRA SETS OF HARDWARE ITEMS #14-#17

8

7

6

5

4

3

2

1

TYP FRAME TO FRAME CONNECTION
* DO OUTSIDE CONNECTIONS
WHEN INSTALLING HANDRAILS

SAME OVERALL LENGTH
AS ITEM #1 MINUS
HOLE PATTERN FOR STAIRS

ALL FRAME
ANGLES RUN
THIS WAY
ITEMS #1-#3

X BRACES
USES 0.5" X 1.75" LONG
HARDWARE
SEE DRW FOR DETAIL

X BRACES
USES 0.5" X 1.75" LONG
HARDWARE
SEE DRW FOR DETAIL

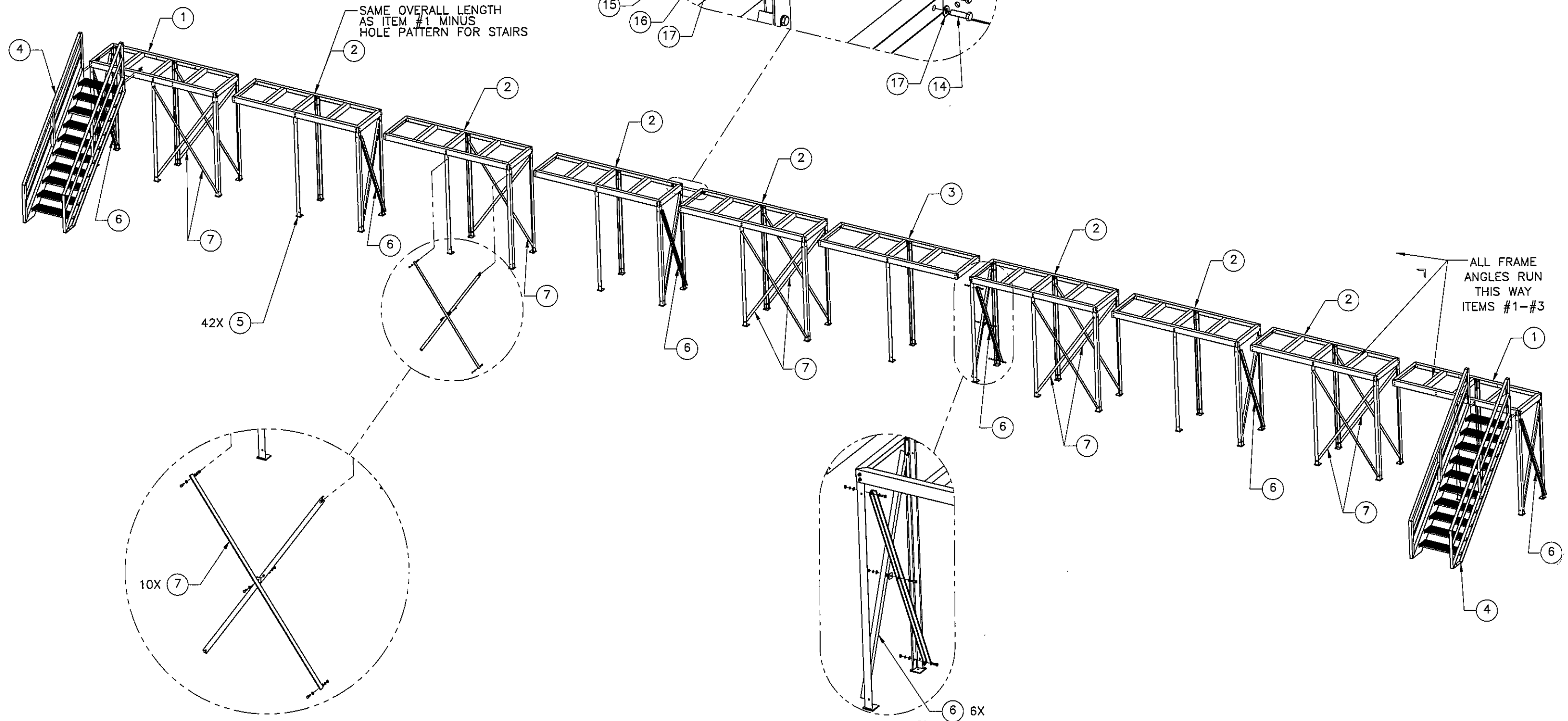

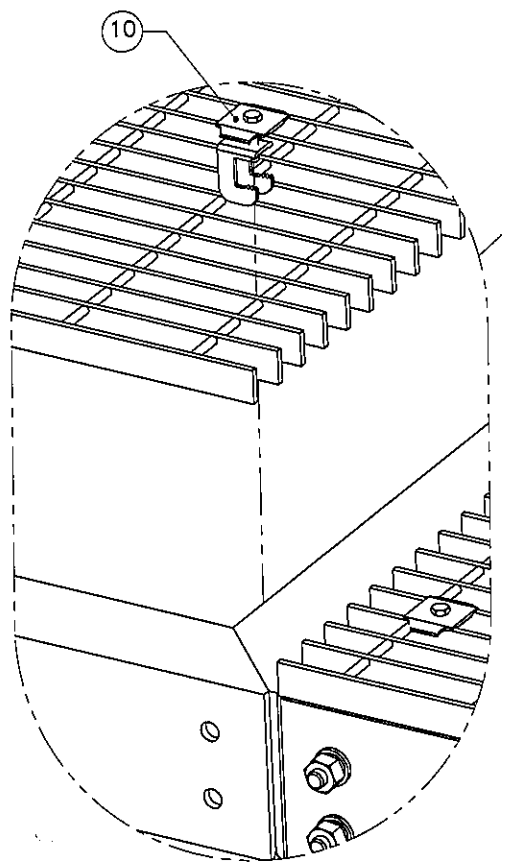
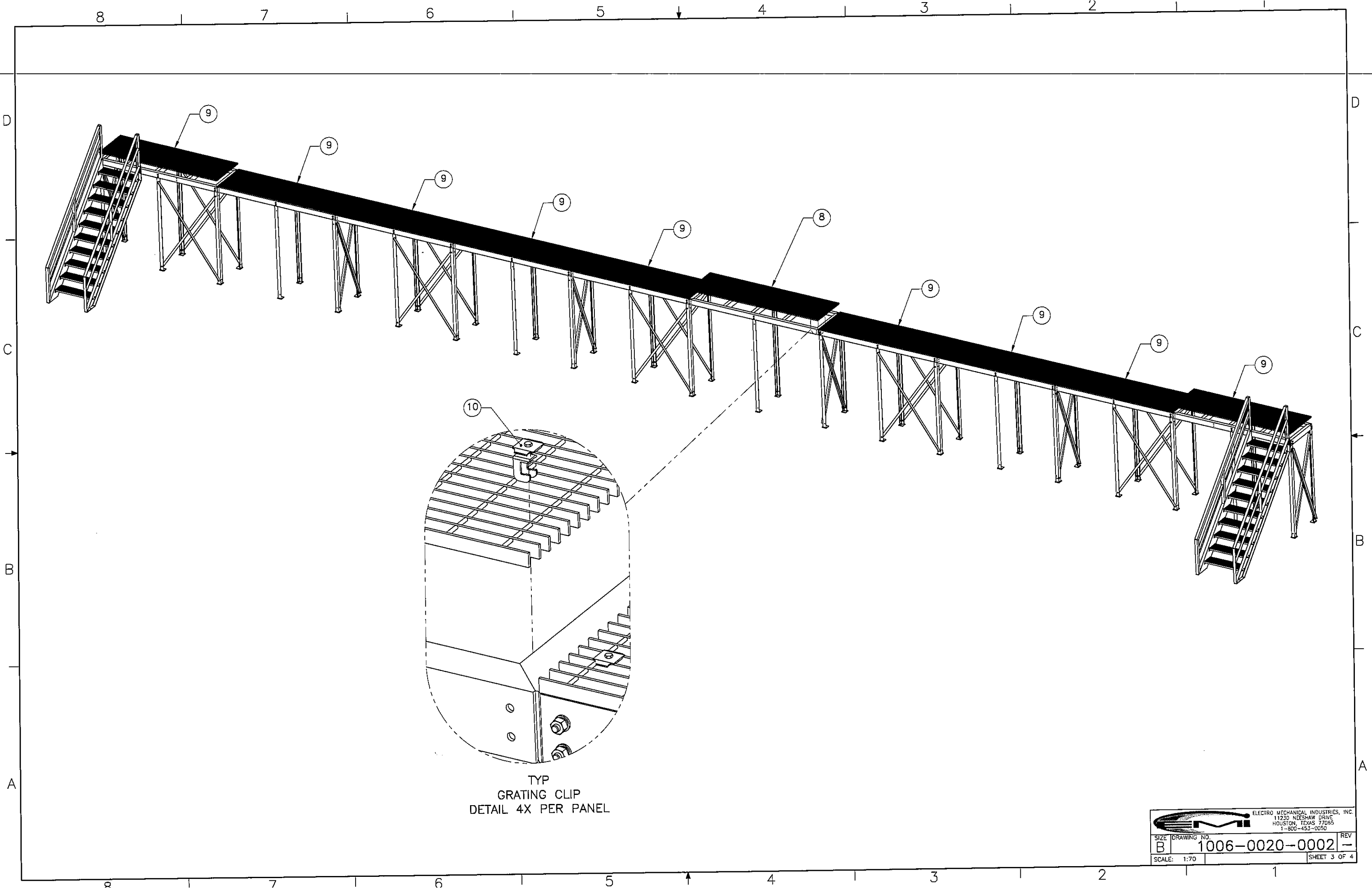

		ELECTRO MECHANICAL INDUSTRIES, INC. 11230 NEESHAW DRIVE HOUSTON, TEXAS 77065 1-800-453-0050	
SIZE	DRAWING NO.	REV	
B	1006-0020-0002		
SCALE: 1:80			SHEET 2 OF 4

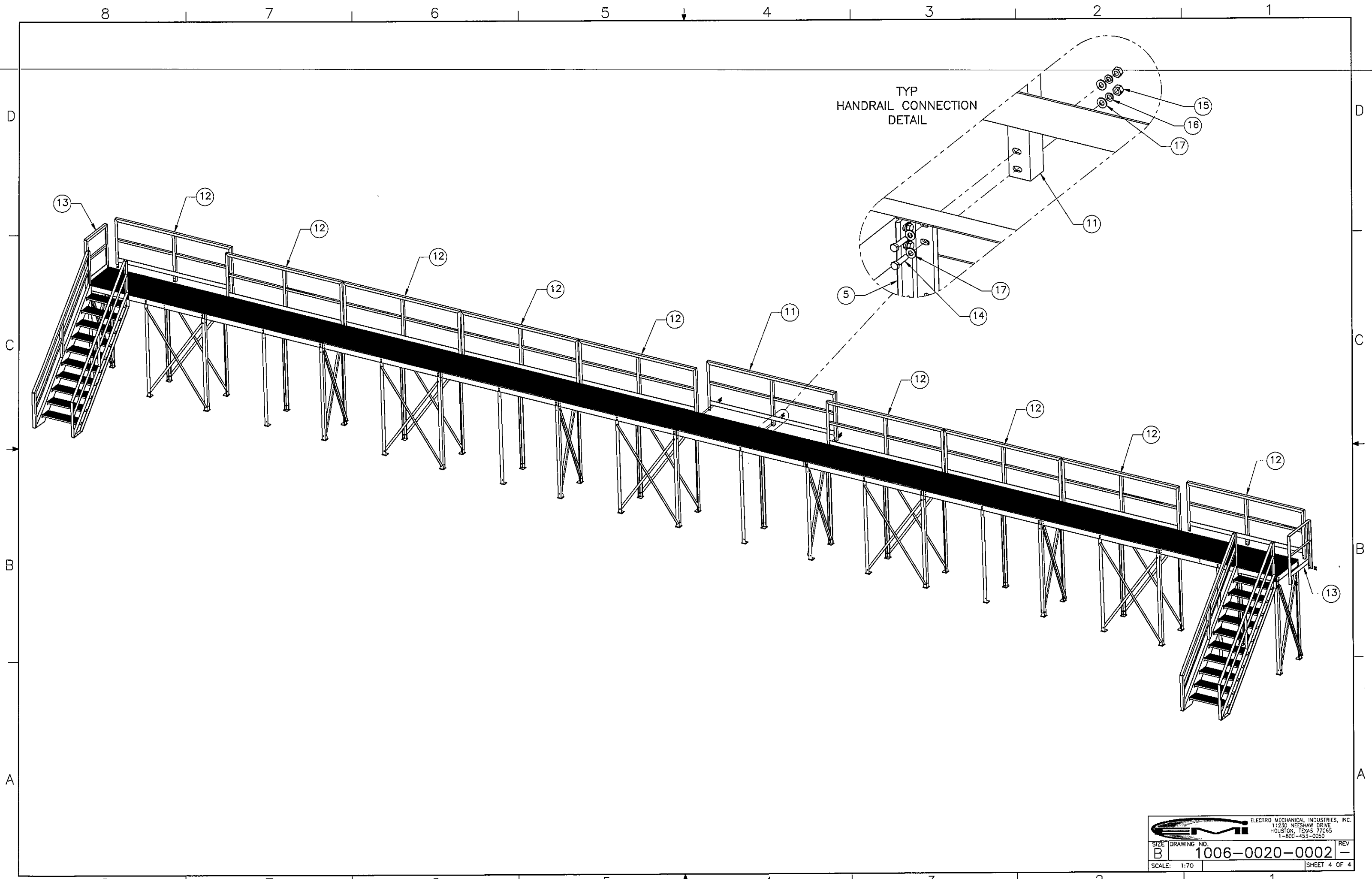

TYP
GRATING CLIP
DETAIL 4X PER PANEL

		ELECTRO MECHANICAL INDUSTRIES, INC.	
		11230 NEEDHAM DRIVE HOUSTON, TEXAS 77065 1-800-453-0050	
SIZE	DRAWING NO.	REV	
B	1006-0020-0002	-	
SCALE: 1:70			SHEET 3 OF 4



		ELECTRO MECHANICAL INDUSTRIES, INC. 11230 NEESHAW DRIVE HOUSTON, TEXAS 77065 1-800-453-0050	
SIZE	DRAWING NO.	REV	
B	1006-0020-0002	-	
SCALE: 1:70	SHEET 4 OF 4		