

THE INFORMATION CONTAINED IN THIS DRAWING IS THE SOLE PROPERTY OF ELECTRO MECHANICAL INDUSTRIES, INC. ANY REPRODUCTION IN PART OR WHOLE WITHOUT THE WRITTEN PERMISSION OF ELECTRO MECHANICAL IND., IS PROHIBITED.

REVISIONS					
REV.	DCN #	DESCRIPTION	DATE	BY	APPROVED
1	01241	(42-3/8") WAS (45-13/16"), (36-3/8") WAS (42"), T010-0180-1180 WAS T010-0203-1180, 002-OGC-G002 WAS 000-MSG-0008, ADDED 002-OFW-G003, UPDATED WITH LOWER LEVEL CHANGES.	03/28/2023	JTR	JPB

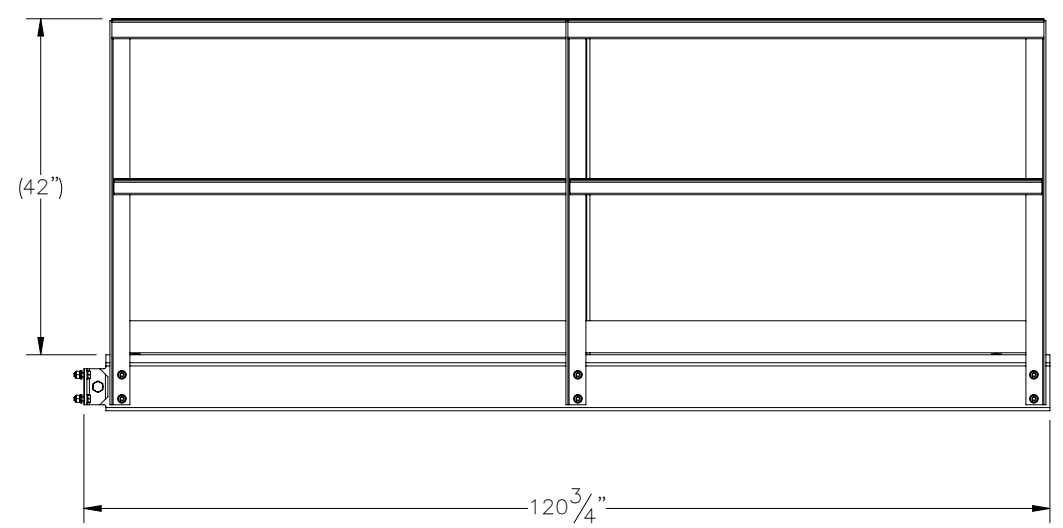
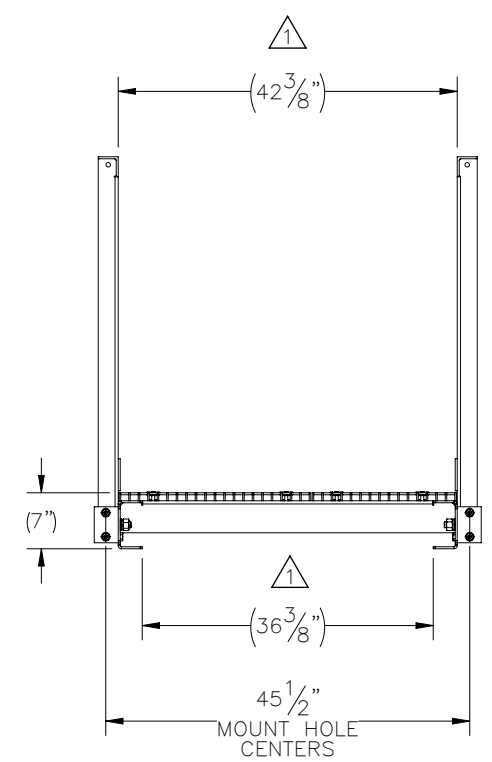
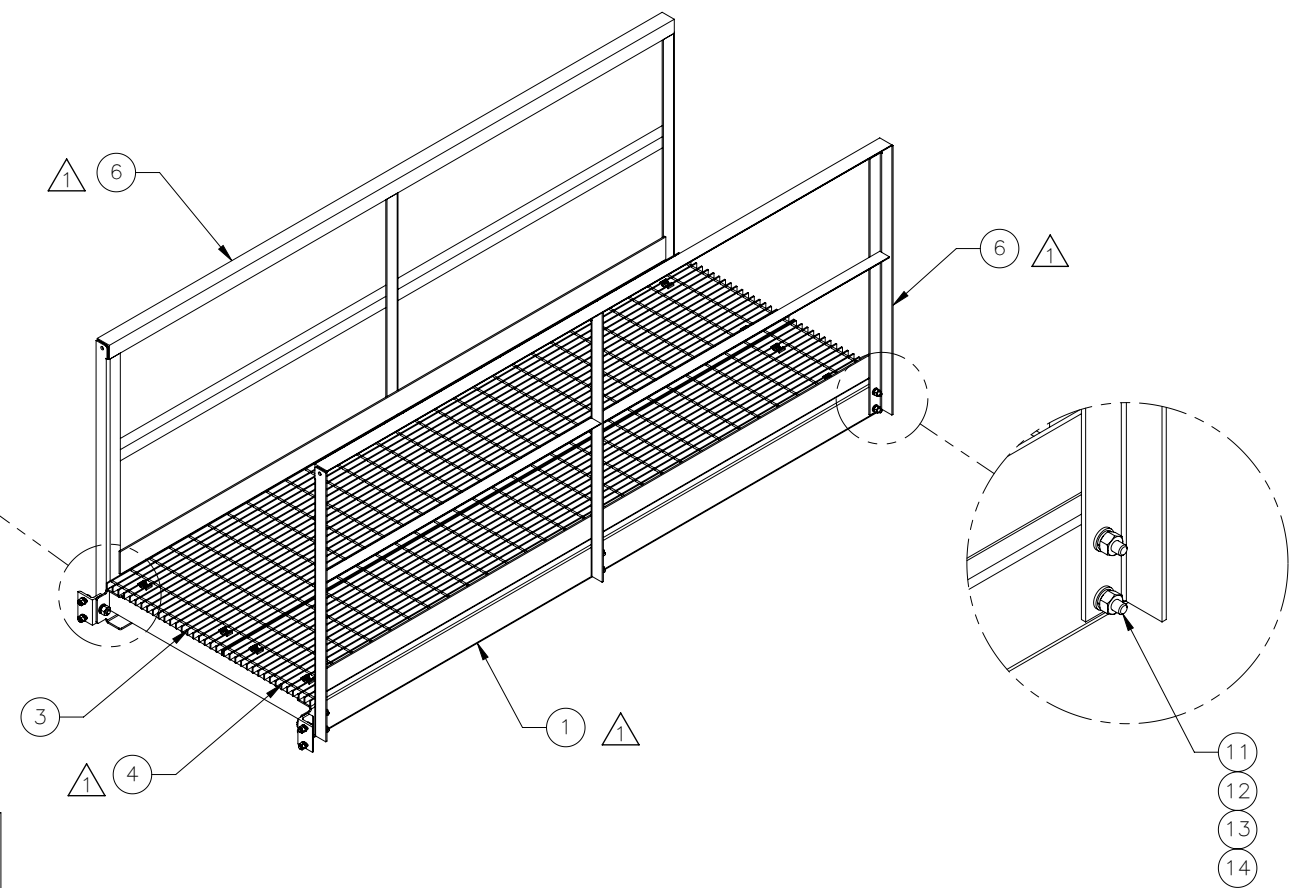
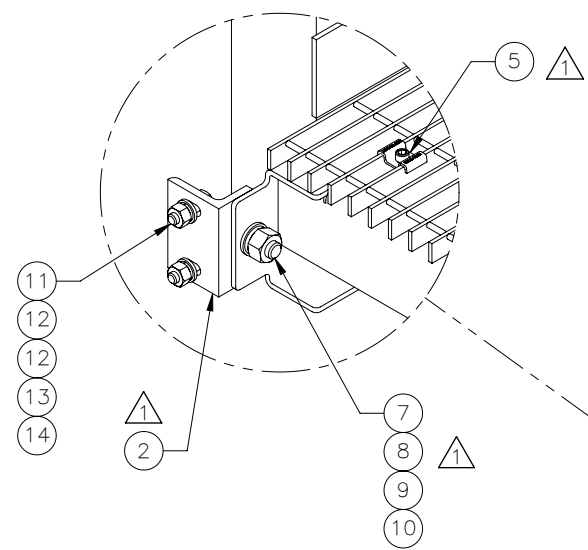

ITEM NO.	QTY REQD	PART NUMBER	DESCRIPTION	LENGTH	WEIGHT
1	1	W-002-381	WALKWAY RAMP WELDMENT 42" X 120"		263.54
2	2	P-001-921	HINGE ANGLE	4 1/2"	2.4
3	1	T010-0240-1180	GRATING PANEL, 1" THK, SMOOTH, 21 BAR, 23.9375 WIDTH	118"	139.2
4	1	T010-0180-1180	GRATING PANEL, 1" SMOOTH, 16 BAR, 18.0 WIDTH	118"	106.0
5	10	002-OGC-G002	GRATE FAST CONNECTOR, 1.1875" BAR WIDTH, 3.25" BOLT		0.4
6	2	1004-T001-1170	ANGLE GUARDRAIL, 117	117"	147.2
7	2	002-0BG-0019	BOLT, HH, .750-10 X 2.00, GALV, A325, PT X 1.375	2"	0.43
8	2	002-0FW-G003	WASHER, FLAT, .750, GALV, F436		0.05
9	2	002-0LW-G003	WASHER, SPLIT LOCK, .750, GALV		0.04
10	2	002-0NG-0002	NUT, HEX, .750-10, GALV, GR 2H		0.189
11	16	002-0BG-0012	BOLT, HH, .500-13 X 1.75, GALV, A325, PT X 1.00	1 3/4"	0.1557
12	20	002-0FW-G002	WASHER, FLAT, .500, GALV, F436		0.03
13	16	002-0LW-G002	WASHER, SPLIT LOCK, .500, GALV		0.014
14	16	002-0NG-0010	NUT, HEX, .500-13, GALV, GR 2H		0.06

NOTES:  
 1 INCLUDES 10% SPARE GRATING CLIPS.

SURFACE FINISH <input checked="" type="checkbox"/> UNLESS OTHERWISE SPECIFIED		UNLESS OTHERWISE SPECIFIED DIMENSIONS ARE IN INCHES		APPROVALS		DATE		ELECTRO MECHANICAL INDUSTRIES, INC. 11230 NEESEHAW DRIVE HOUSTON, TEXAS 77065 1-800-453-0050	
MATERIAL SEE PARTS LIST		TOLERANCES .0 ±.06 .00 ±.015 .000 ±.005		DRAWN C. SANCHEZ		6/14/2022			
THIRD ANGLE PROJECTION		FRACTIONS ± 1/16		CHECKER J. ROACH		6/14/2022		TITLE: 42" X 120" WALKWAY RAMP	
NEXT ASSY		ANGLES ± .25°		ENGINEER J. Breen		6/14/2022			
USED ON		HOLES: DRILLED OR PUNCHED ± 1/32		PRODUCTION J. LEE		6/14/2022		SIZE B DRAWING NO. 1006-0010-0010 REV 1	
APPLICATIONS		BURNED ± 1/32		SCALE: 1:24		WEIGHT: 818.0 lbs.		SHEET 1 OF 1	