

THE INFORMATION CONTAINED IN THIS DRAWING IS THE SOLE PROPERTY OF ELECTRO MECHANICAL INDUSTRIES, INC. ANY REPRODUCTION IN PART OR WHOLE WITHOUT THE WRITTEN PERMISSION OF ELECTRO MECHANICAL IND., IS PROHIBITED.

REVISIONS					
REV.	DCN #	DESCRIPTION	DATE	BY	APPROVED
1	01241	(42-3/8") WAS (45-13/16"), (36-3/8") WAS (42"), T010-0180-1060 WAS T010-0203-1060, 002-0GC-G002 WAS 000-MSG-0008, 002-0BG-0019 WAS 002-0BG-0268, ADDED 002-0FW-G003, 002-0BG-0012 WAS 002-0BG-0026, UPDATED WITH LOWER LEVEL CHANGES.	03/27/2023	JTR	JPB

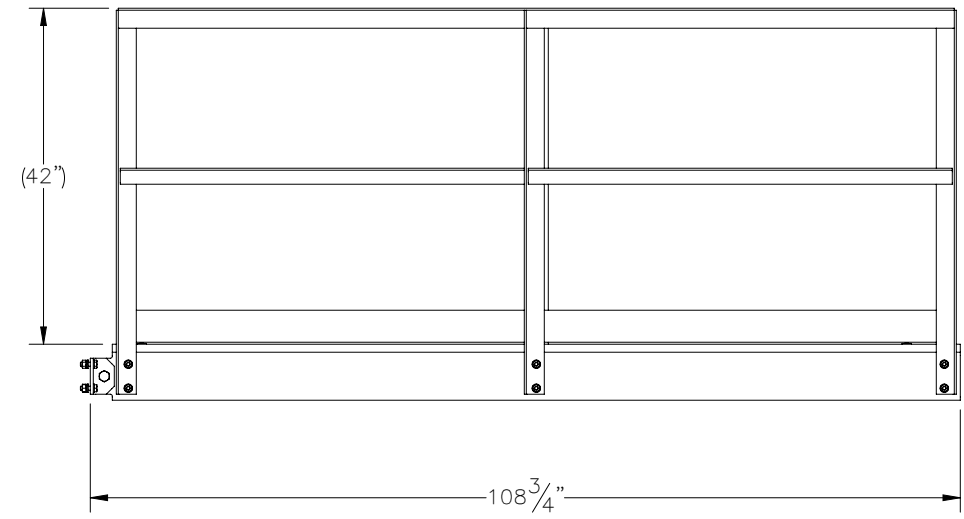
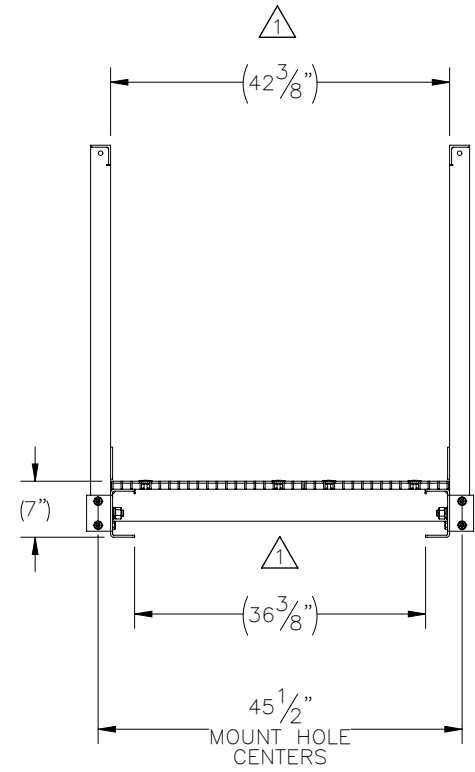
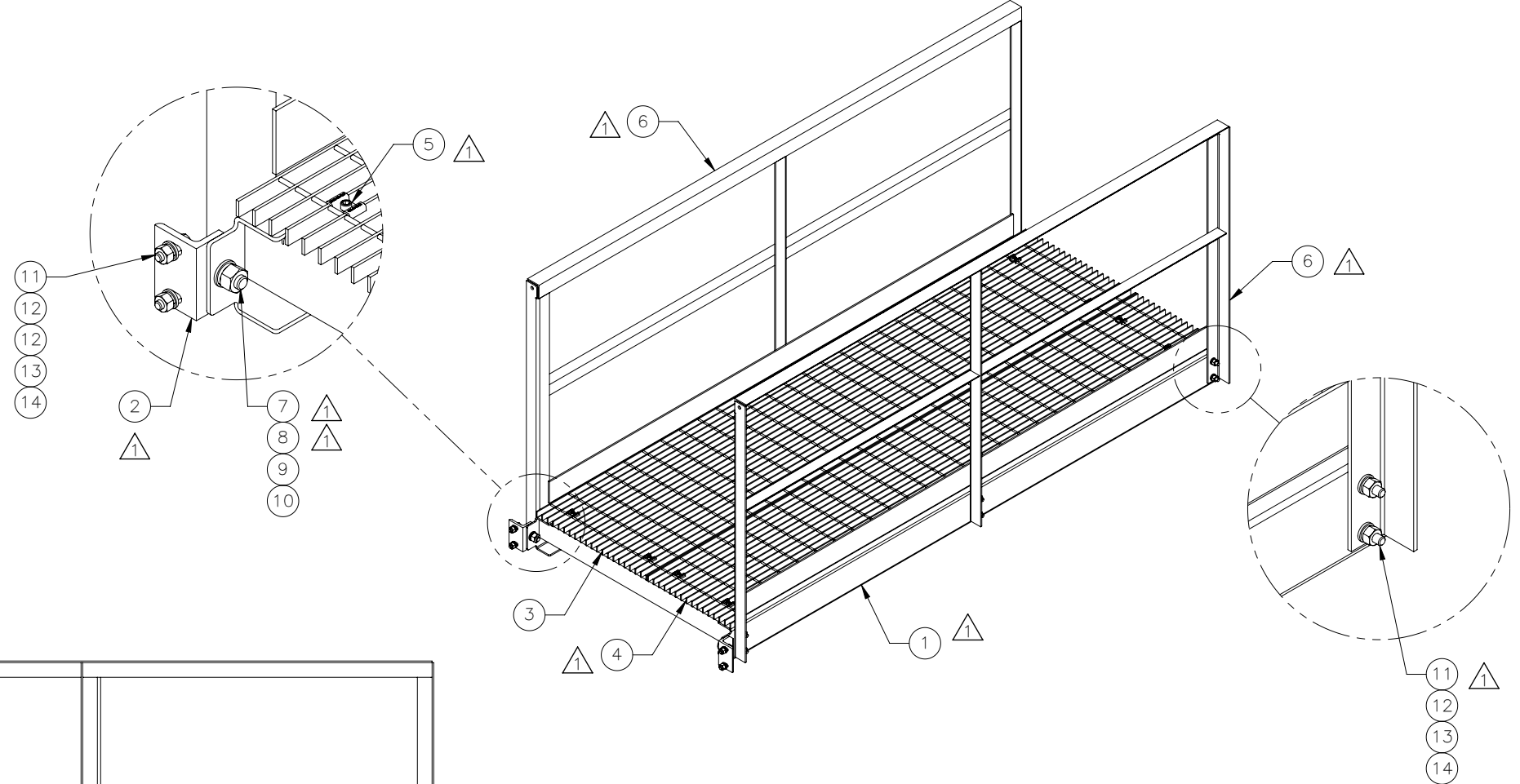

ITEM NO.	QTY REQD	PART NUMBER	DESCRIPTION	LENGTH	WEIGHT
1	1	W-001-808	WALKWAY RAMP WELDMENT 42" X 108"		244.38
2	2	P-001-921	HINGE ANGLE	4 1/2"	2.4
3	1	T010-0240-1060	GRATING PANEL, 1" THK, SMOOTH, 21 BAR, 23.9375 WIDTH	106"	124.8
4	1	T010-0180-1060	GRATING PANEL, 1" SMOOTH, 16 BAR, 18.0 WIDTH	106"	95.0
5	10	002-0GC-G002	GRATE FAST CONNECTOR, 1.1875" BAR WIDTH, 3.25" BOLT		0.4
6	2	1004-T001-1050	ANGLE GUARDRAIL, 105	105"	136.6
7	2	002-0BG-0019	BOLT, HH, .750-10 X 2.00, GALV, A325, PT X 1.375	2"	0.43
8	2	002-0FW-G003	WASHER, FLAT, .750, GALV, F436		0.05
9	2	002-0LW-G003	WASHER, SPLIT LOCK, .750, GALV		0.04
10	2	002-0NG-0002	NUT, HEX, .750-10, GALV, GR 2H		0.189
11	16	002-0BG-0012	BOLT, HH, .500-13 X 1.75, GALV, A325, PT X 1.00	1 3/4"	0.1557
12	20	002-0FW-G002	WASHER, FLAT, .500, GALV, F436		0.03
13	16	002-0LW-G002	WASHER, SPLIT LOCK, .500, GALV		0.014
14	16	002-0NG-0010	NUT, HEX, .500-13, GALV, GR 2H		0.06

NOTES:  
 1 INCLUDES 10% SPARE GRATING CLIPS.

SURFACE FINISH <input checked="" type="checkbox"/> UNLESS OTHERWISE SPECIFIED		UNLESS OTHERWISE SPECIFIED DIMENSIONS ARE IN INCHES		APPROVALS		DATE		ELECTRO MECHANICAL INDUSTRIES, INC. 11230 NEESESHAW DRIVE HOUSTON, TEXAS 77065 1-800-453-0050	
MATERIAL SEE PARTS LIST		TOLERANCES		DRAWN C. SANCHEZ		1/23/2018			
THIRD ANGLE PROJECTION		FRACTIONS ± 1/16		CHECKER J. CRITELLI		1/24/2018		TITLE: <b>42" X 108" WALKWAY RAMP</b>	
NEXT ASSY		ANGLES ± .25°		ENGINEER C. SANCHEZ		1/24/2018			
USED ON		HOLES: DRILLED OR PUNCHED ± 1/32		PRODUCTION JKS		1/24/2018		SIZE B DRAWING NO. 1006-0010-0003 REV 1	
APPLICATIONS		BURNED ± 1/32		SCALE: 1:24		WEIGHT: 752.3 lbs.		SHEET 1 OF 1	