

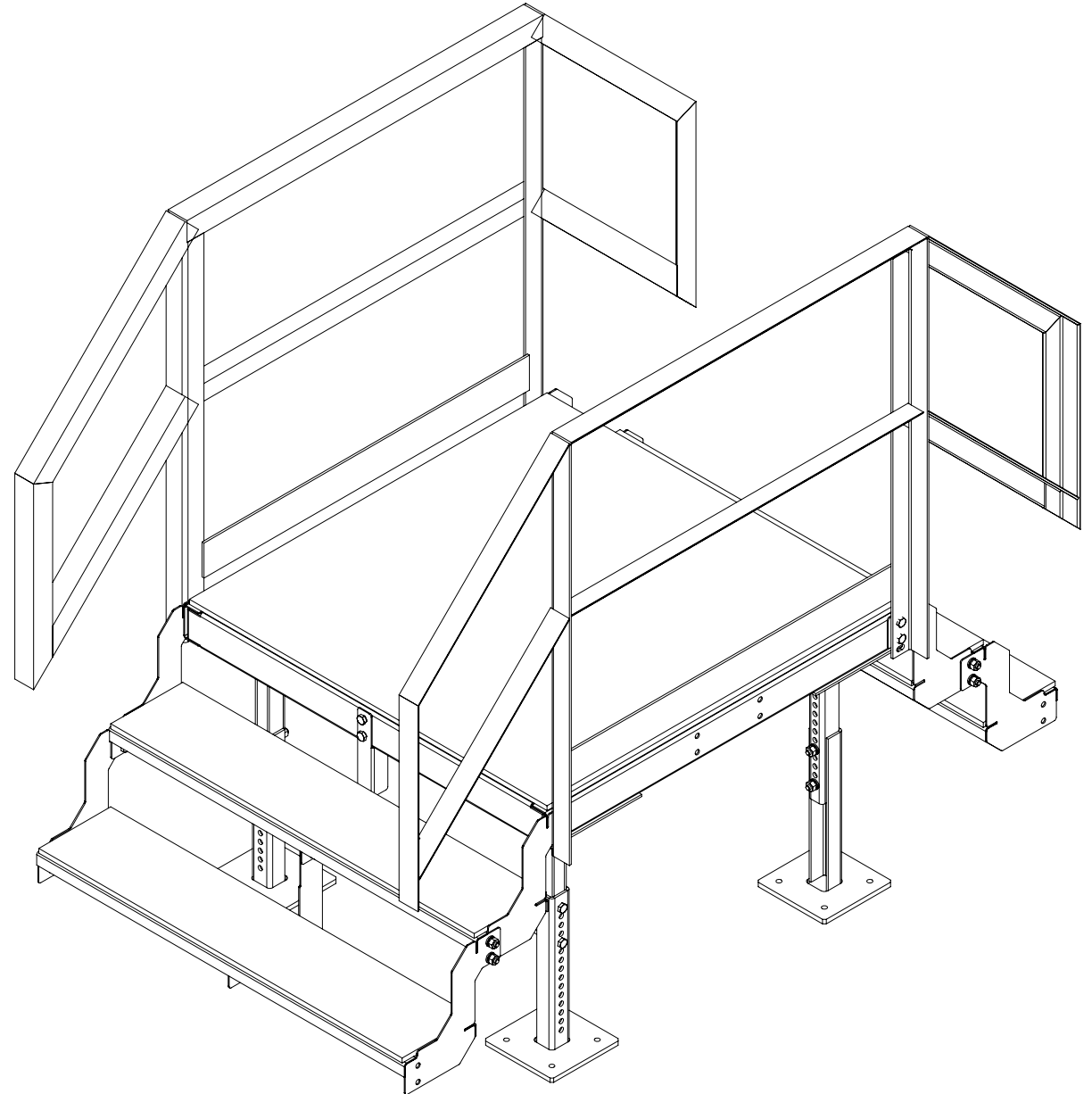

THE INFORMATION CONTAINED IN THIS DRAWING IS THE SOLE PROPERTY OF ELECTRO MECHANICAL INDUSTRIES, INC. ANY REPRODUCTION IN PART OR WHOLE WITHOUT THE WRITTEN PERMISSION OF ELECTRO MECHANICAL IND., IS PROHIBITED.

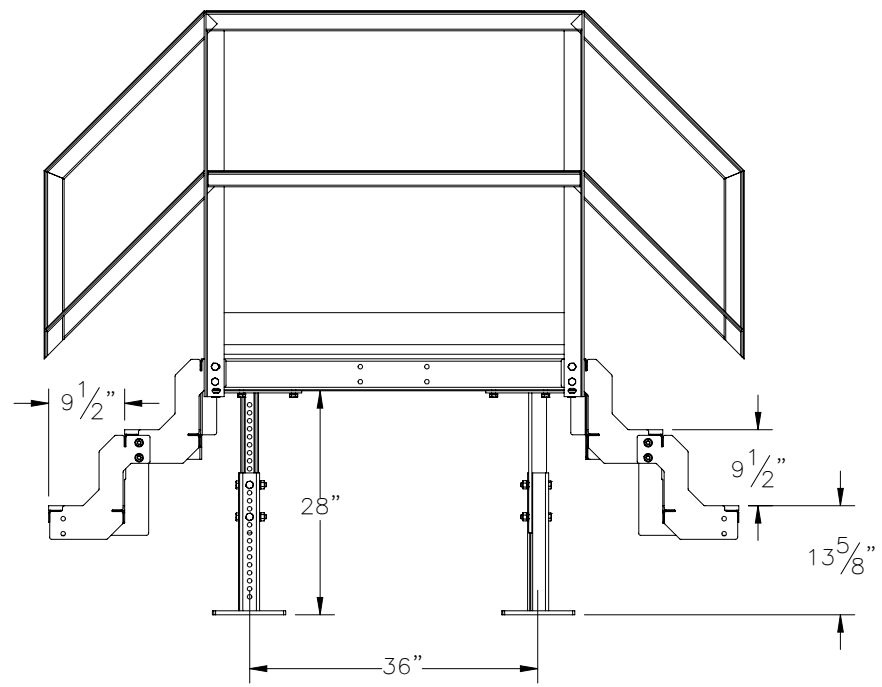
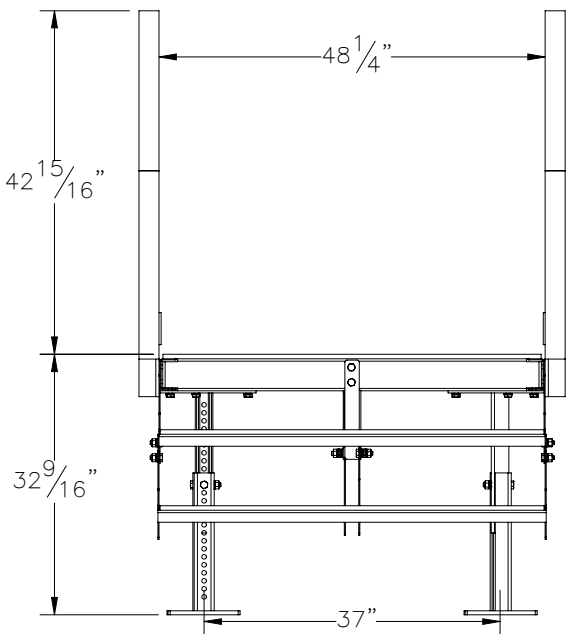
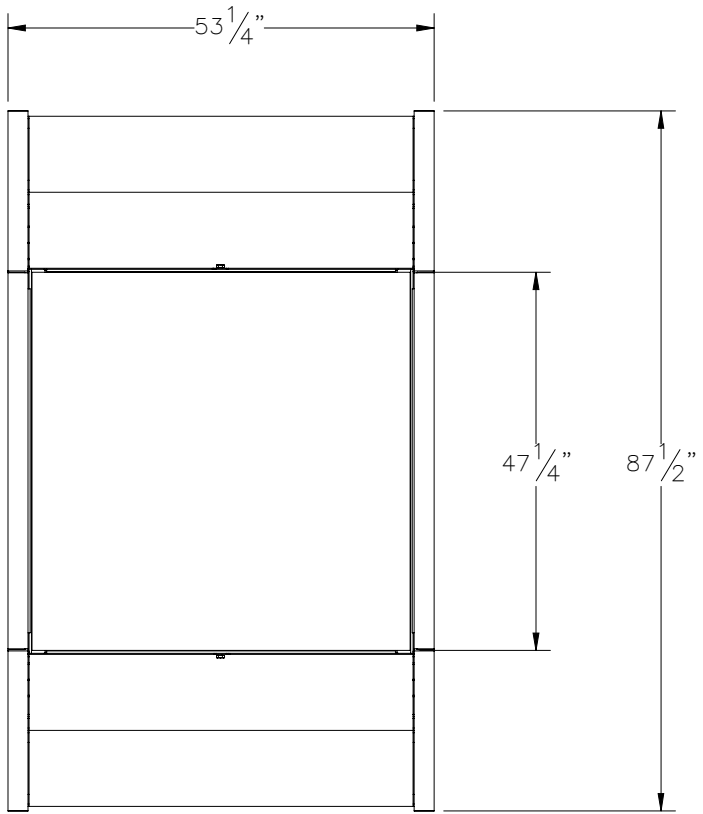
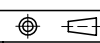

SALES

SURFACE FINISH <input checked="" type="checkbox"/> UNLESS OTHERWISE SPECIFIED		UNLESS OTHERWISE SPECIFIED DIMENSIONS ARE IN INCHES		APPROVALS	DATE	 ELECTRO MECHANICAL INDUSTRIES, INC. 11230 NEESESHAW DRIVE HOUSTON, TEXAS 77065 1-800-453-0050
MATERIAL	SEE PARTS LIST	TOLERANCES		DRAWN	2/26/2024	
THIRD ANGLE PROJECTION		.0	± .06	CHECKER	2/26/2024	TITLE:
		.00	± .015	ENGINEER	2/26/2024	4' x 4' STEP OVER WITH GRAVITY FEET, 28" ELEV
		.000	± .005	PRODUCTION	2/26/2024	SIZE
NEXT ASSY	USED ON	FRACTIONS	± 1/16	J. Breen		DRAWING NO.
		ANGLES	± .25°			1000-0030-0198
		HOLES:				REV
APPLICATIONS		DRILLED OR PUNCHED	+1/32			0
		BURNED	±1/32			SCALE: 1:24
						WEIGHT: 1184.41 lbs.
						SHEET 1 OF 1