

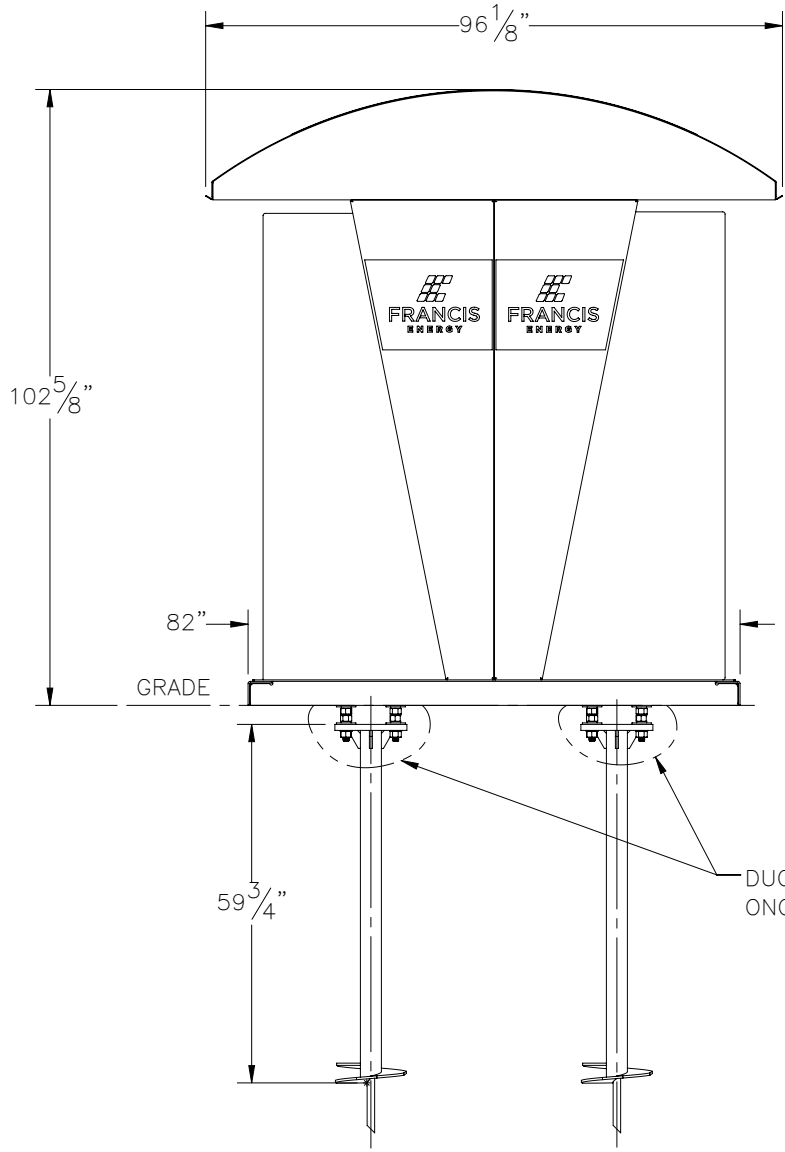

THE INFORMATION CONTAINED IN THIS DRAWING IS THE SOLE PROPERTY OF ELECTRO MECHANICAL INDUSTRIES, INC. ANY REPRODUCTION IN PART OR WHOLE WITHOUT THE WRITTEN PERMISSION OF ELECTRO MECHANICAL IND., IS PROHIBITED.

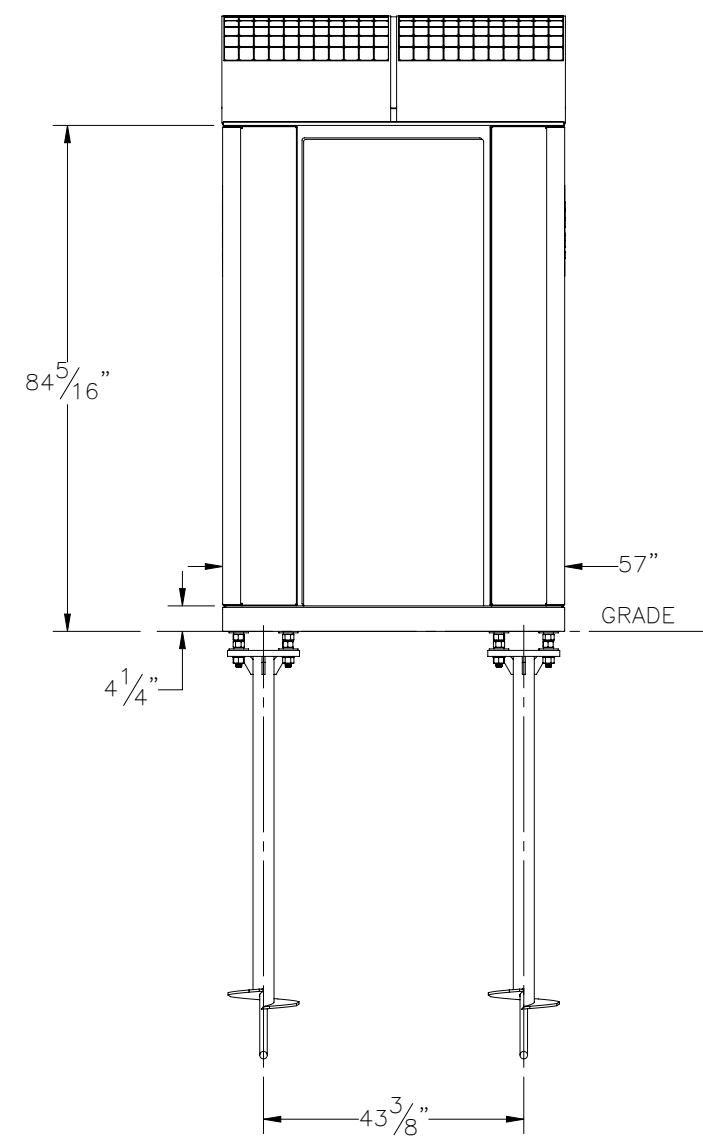

DUG OUT AND BACK FILLED
ONCE HELICAL IS SET.

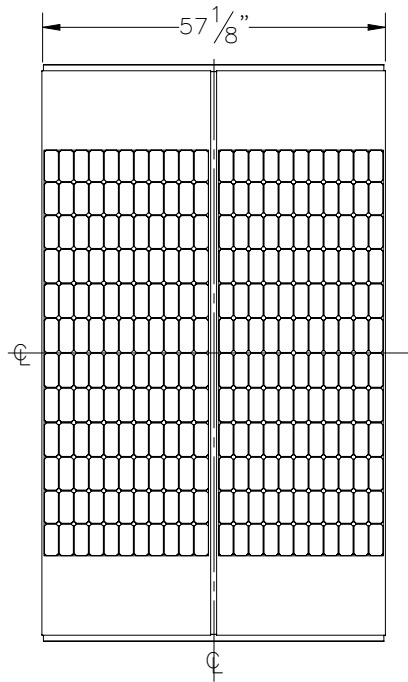
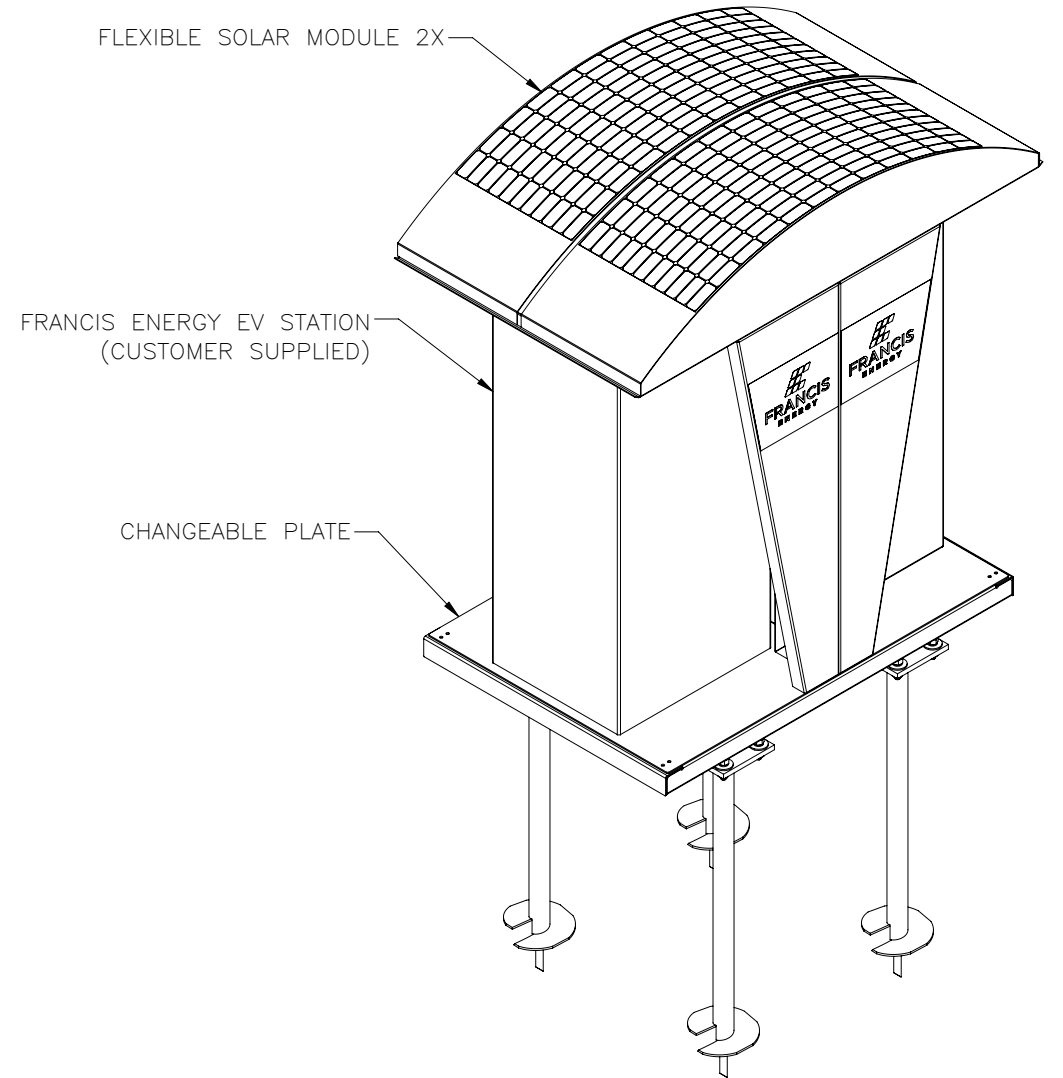

SALES DRAWING

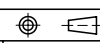
| | | | | | | |
|---|---|--|--|------------|-----------|--|
| SURFACE FINISH <input checked="" type="checkbox"/> UNLESS OTHERWISE SPECIFIED | | UNLESS OTHERWISE SPECIFIED DIMENSIONS ARE IN INCHES | | APPROVALS | DATE |  ELECTRO MECHANICAL INDUSTRIES, INC. 11230 NEESHAW DRIVE HOUSTON, TEXAS 77065 1-800-453-0050 |
| MATERIAL | GALVANIZED STEEL | TOLERANCES | | DRAWN | 3/11/2024 | |
| THIRD ANGLE PROJECTION |  | .0 ± .06 .00 ± .015 .000 ± .005 | | CHECKER | | TITLE: |
| NEXT ASSY | USED ON | FRACTIONS ± 1/16 ANGLES ± .25° | | ENGINEER | | 82" X 57" X HELICAL MOUNT PLINTH W/ CANOPY |
| APPLICATIONS | | HOLES: DRILLED OR PUNCHED ± 1/32 BURNED ± 1/32 | | PRODUCTION | | SIZE |
| | | | | | | DRAWING NO. |
| | | | | | | 1000-0010-0519 |
| | | | | | | REV |
| | | | | | | A |
| | | | | | | SCALE: 1:32 |
| | | | | | | WEIGHT: 7964.75 lbs. |
| | | | | | | SHEET 1 OF 2 |

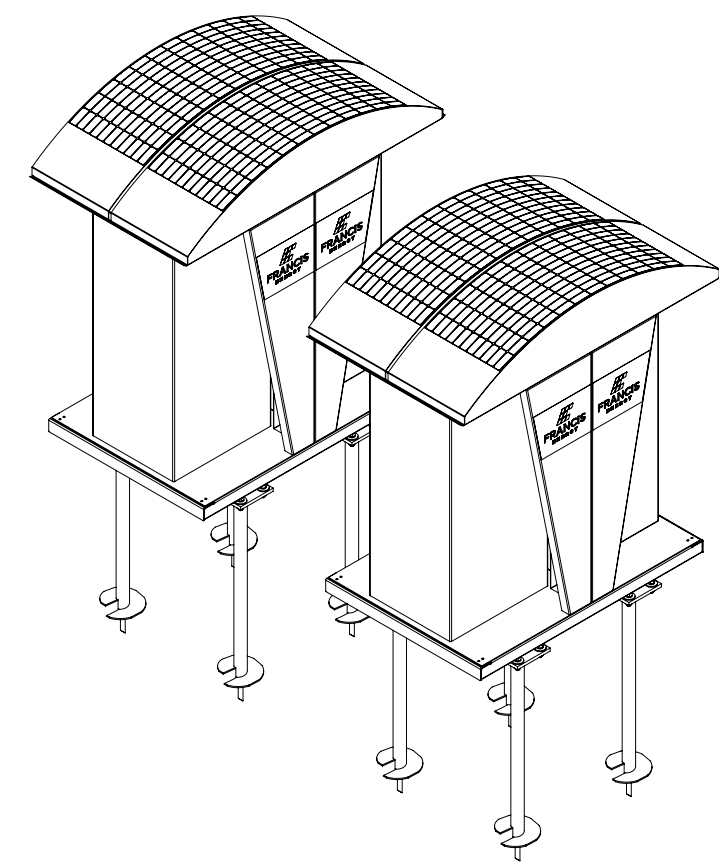
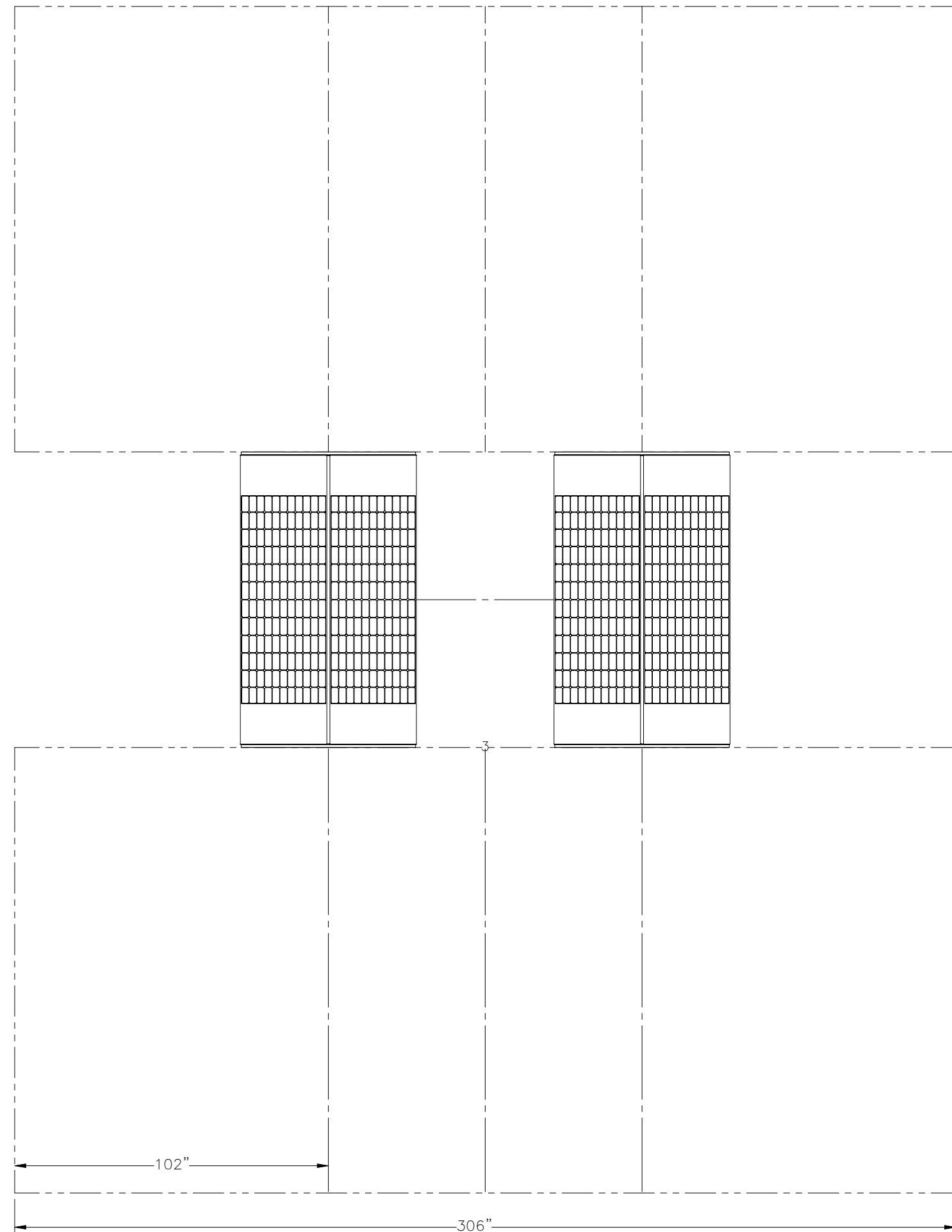

| | | | |
|-------------|----------------|--|--|
| | | ELECTRO MECHANICAL INDUSTRIES, INC. 11230 NEESHAW DRIVE HOUSTON, TEXAS 77065 1-800-453-0050 | |
| SIZE | DRAWING NO. | REV | |
| B | 1000-0010-0519 | A | |
| SCALE: 1:40 | | SHEET 2 OF 2 | |