

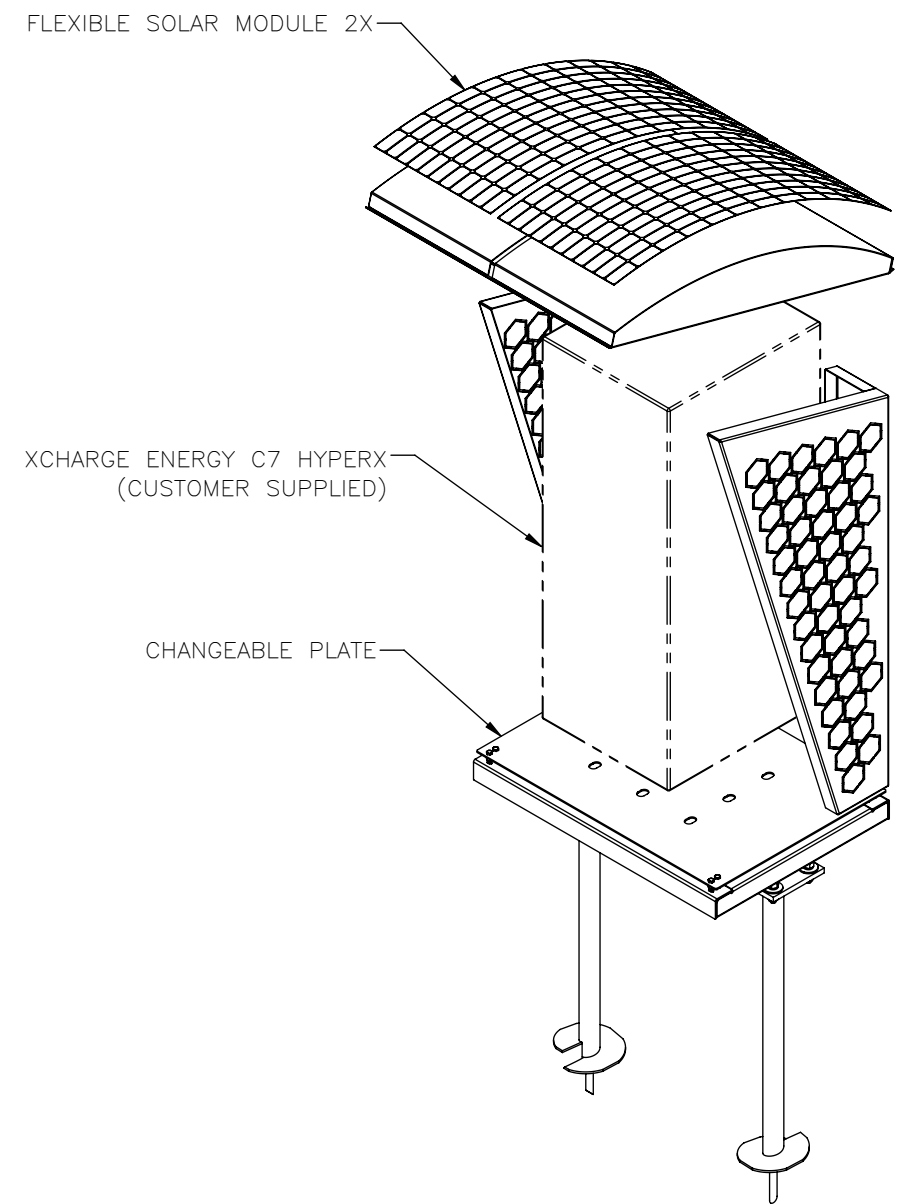

THE INFORMATION CONTAINED IN THIS DRAWING IS THE SOLE PROPERTY OF ELECTRO MECHANICAL INDUSTRIES, INC. ANY REPRODUCTION IN PART OR WHOLE WITHOUT THE WRITTEN PERMISSION OF ELECTRO MECHANICAL IND., IS PROHIBITED.

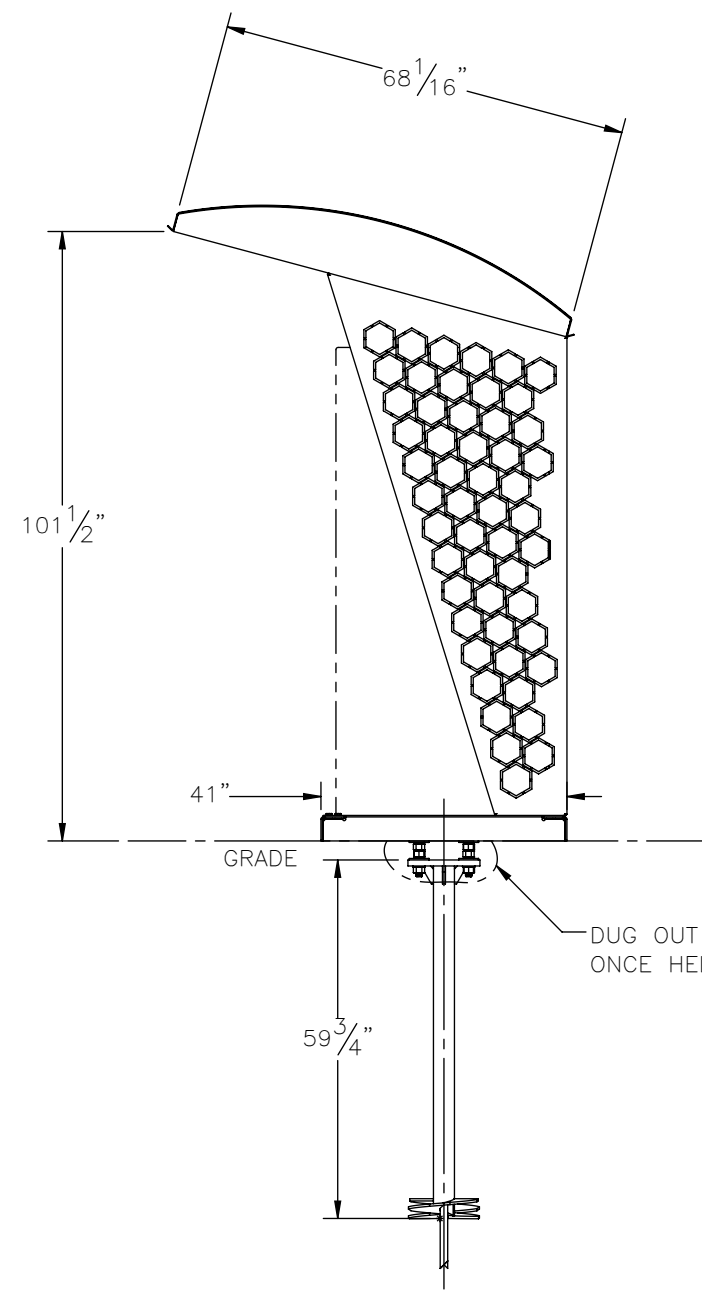
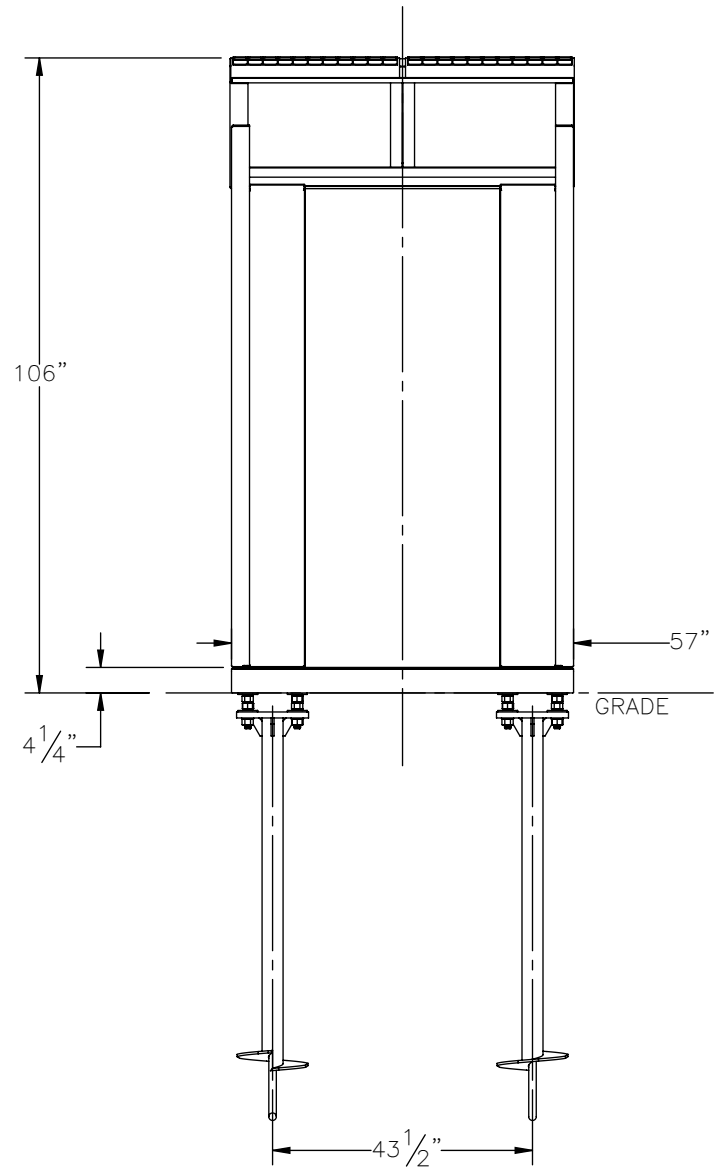
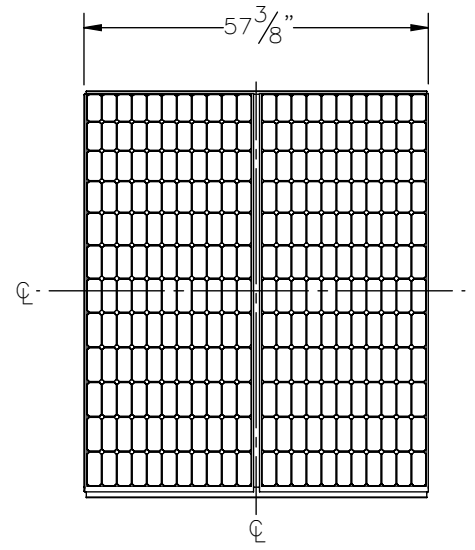
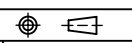

SALES DRAWING

SURFACE FINISH ✓ UNLESS OTHERWISE SPECIFIED		UNLESS OTHERWISE SPECIFIED DIMENSIONS ARE IN INCHES		APPROVALS	DATE	 ELECTRO MECHANICAL INDUSTRIES, INC. 11230 NEESHAW DRIVE HOUSTON, TEXAS 77065 1-800-453-0050
MATERIAL	GALVANIZED STEEL	TOLERANCES		DRAWN	2/27/2024	
THIRD ANGLE PROJECTION		.0	± .06	CHECKER		63" X 48" HELICAL MOUNT PLINTH W/ CANOPY
		.00	± .015	ENGINEER		
		.000	± .005	PRODUCTION		SIZE
NEXT ASSY	USED ON	FRACTIONS	± 1/16			DRAWING NO.
		ANGLES	± .25°			1000-0010-0518
		HOLES:				REV
APPLICATIONS		DRILLED OR PUNCHED	+/- 1/32			A
		BURNED	± 1/32			SCALE: 1:32
						WEIGHT: 1087.68 lbs.
						SHEET 1 OF 1