

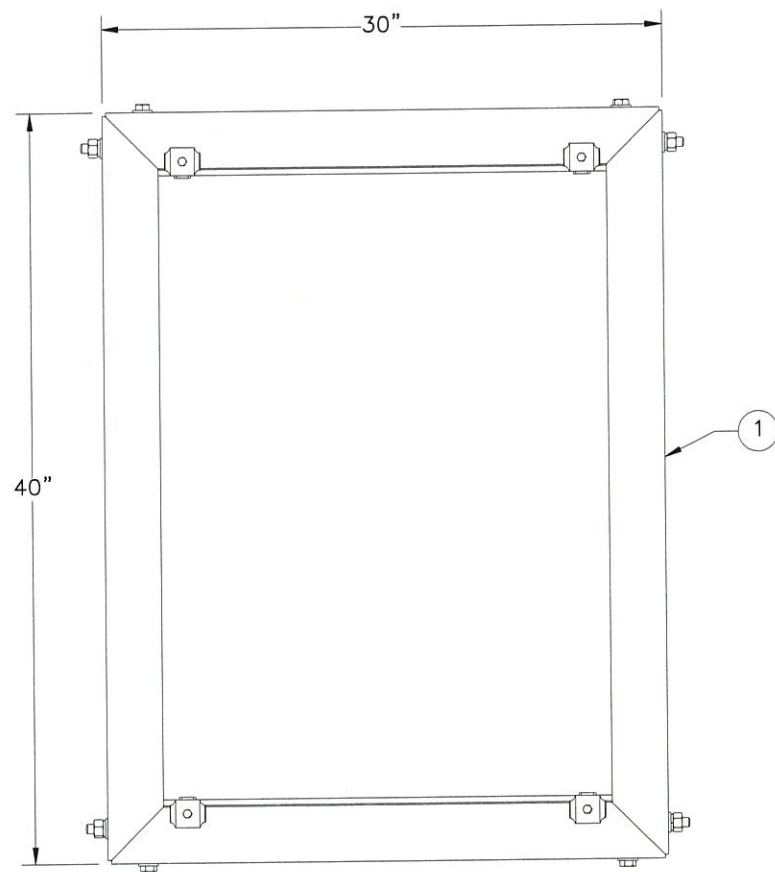

THE INFORMATION CONTAINED IN THIS DRAWING IS THE SOLE PROPERTY OF ELECTRO MECHANICAL INDUSTRIES, INC. ANY REPRODUCTION IN PART OR WHOLE WITHOUT THE WRITTEN PERMISSION OF ELECTRO MECHANICAL IND., IS PROHIBITED.

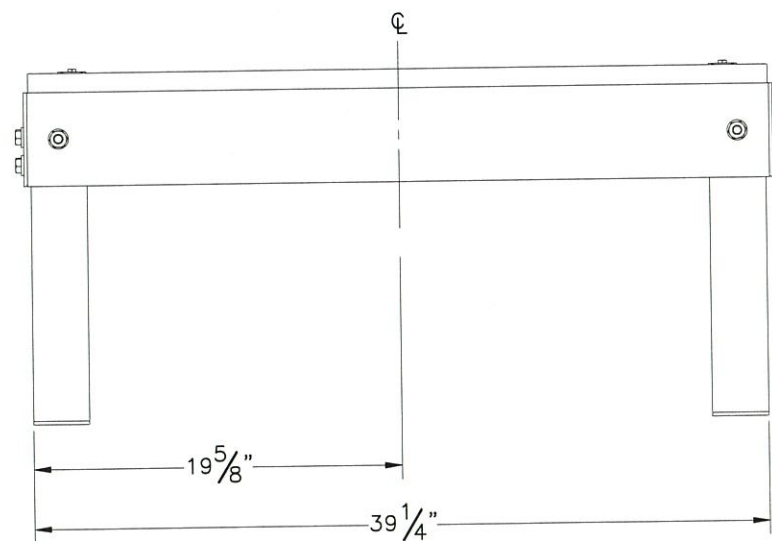

GRATING REMOVED

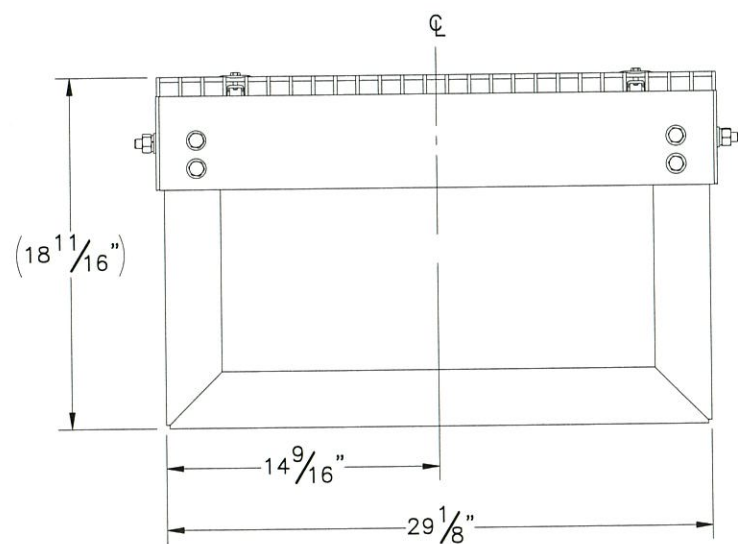
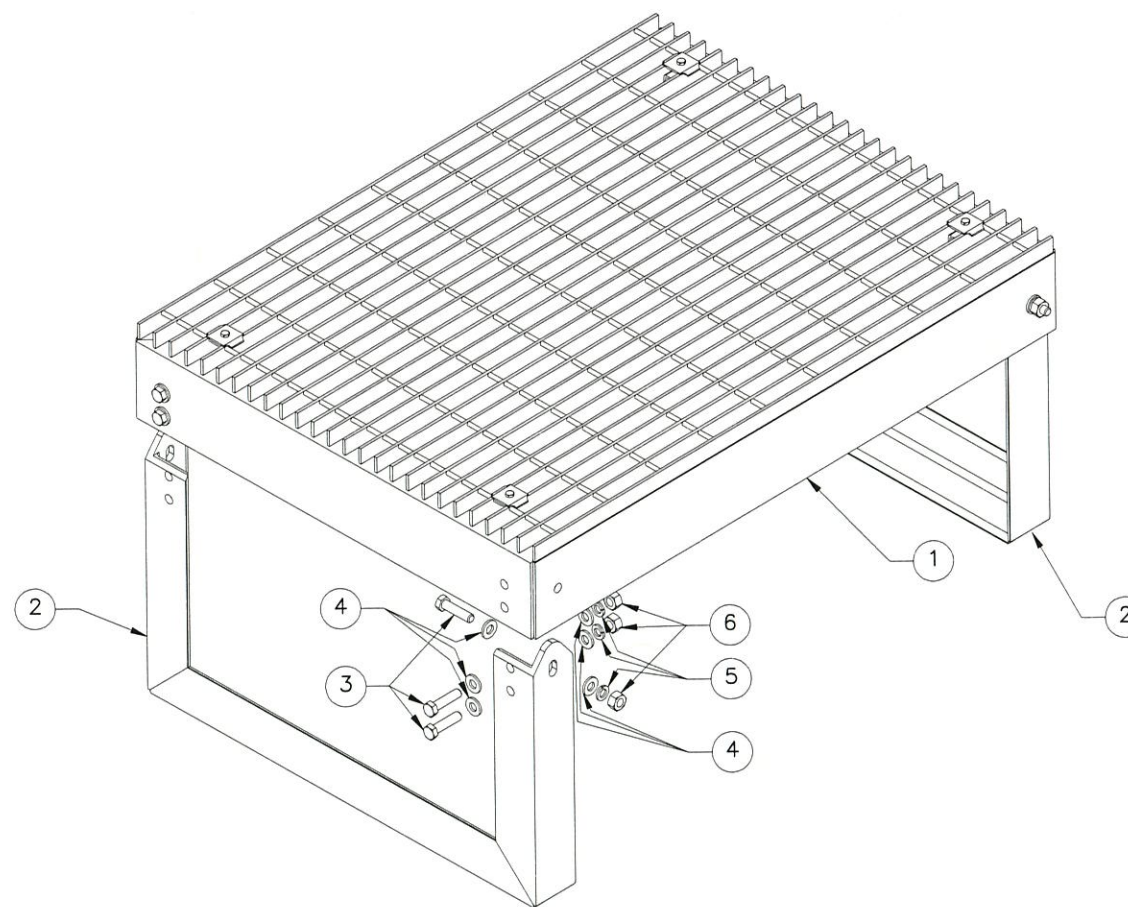

ITEM NO.	QTY REQD	PART NUMBER	DESCRIPTION	LENGTH	WEIGHT
1	1	1001-0020-0090	30" X 40" BOLT TOGETHER PLATFORM		166.0
2	2	W-001-763	SUPPORT LEG WELDMENT	29 1/8"	33.59
3	12	002-0BG-0262	BOLT, HX HD, .500-13UNC, 2.00 LG, FULL THD, GR 5, GALV		0.15
4	24	002-0FW-G002	WASHER, FLAT, .500", F436, GALV		0.02
5	12	002-0LW-G002	WASHER, SPLIT LOCK, .500", GALV		0.01
6	12	002-0NG-0010	NUT, HEX, .500-13UNC, GR 2H, GALV		0.06

SURFACE FINISH <input checked="" type="checkbox"/> UNLESS OTHERWISE SPECIFIED		UNLESS OTHERWISE SPECIFIED DIMENSIONS ARE IN INCHES		APPROVALS	DATE	 ELECTRO MECHANICAL INDUSTRIES, INC. 11230 NEESEHAW DRIVE HOUSTON, TEXAS 77065 1-800-453-0050	
MATERIAL	SEE PARTS LIST	TOLERANCES		DRAWN	2019-12-05		
THIRD ANGLE PROJECTION		.0 ±.06 .00 ±.01 .000 ±.005		CHECKED	12/16/19	TITLE:	
NEXT ASSY	USED ON	FRACTIONS ± 1/16 ANGLES ± .25°		ENGINEER/DISIGNER	12/29/19	30" X 40" BOLT TOGETHER PLATFORM	
APPLICATIONS		DRILLED OR PUNCHED +1/32 BURNED ±1/32		PRODUCTION	12-23-19		REV
				SCALE: 1:32	WEIGHT: 236.5 lbs.	DRAWING NO. 1000-0010-0210	SHEET 1 OF 1