

THE INFORMATION CONTAINED IN THIS DRAWING IS THE SOLE PROPERTY OF ELECTRO MECHANICAL INDUSTRIES, INC. ANY REPRODUCTION IN PART OR WHOLE WITHOUT THE WRITTEN PERMISSION OF ELECTRO MECHANICAL IND., IS PROHIBITED.

REVISIONS					
REV.	DCN #	DESCRIPTION	DATE	BY	APPROVED
9	01129	UPDATED PER LOWER LEVEL CHANGES TO 1003-0000-0016 AND 1003-0000-0020	03/18/2022	JTR	JPB

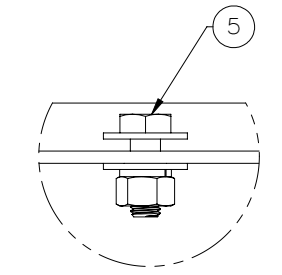

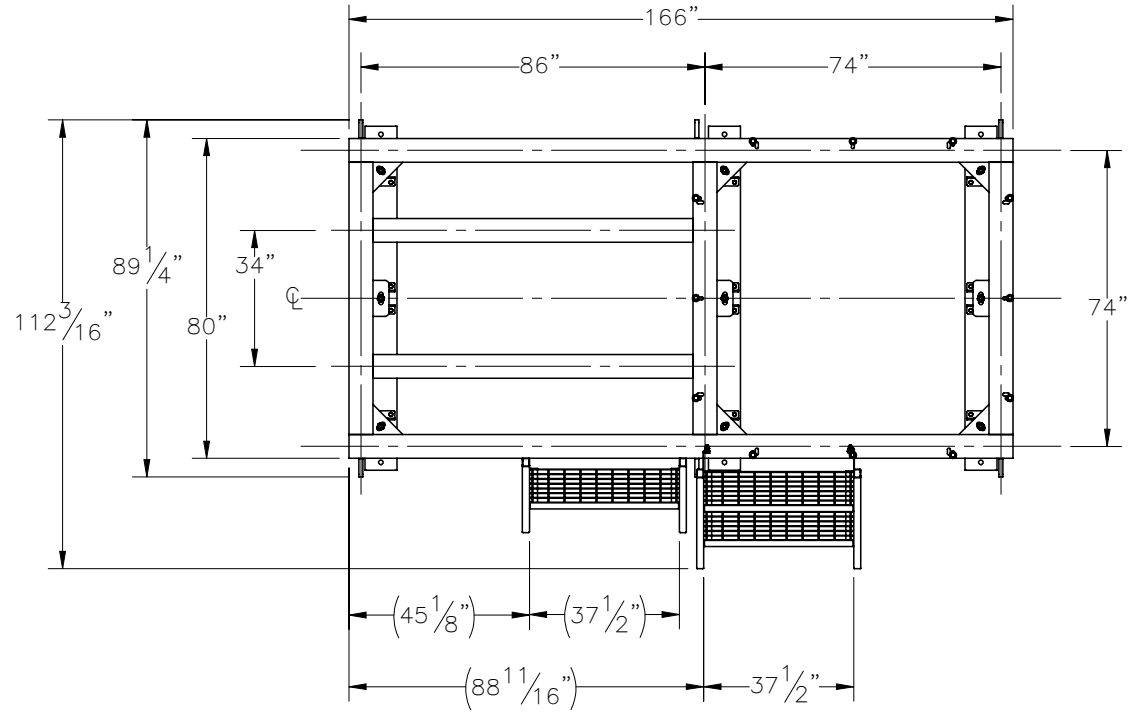
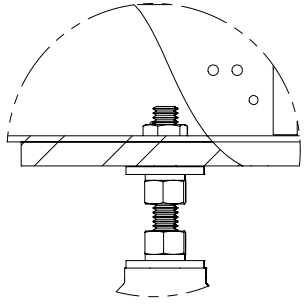

DETAIL B
TYP WIC
MOUNT HARDWARE

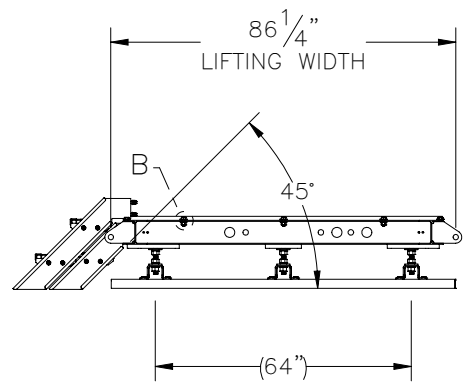
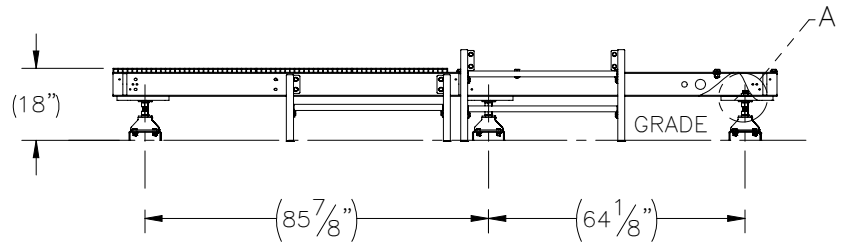
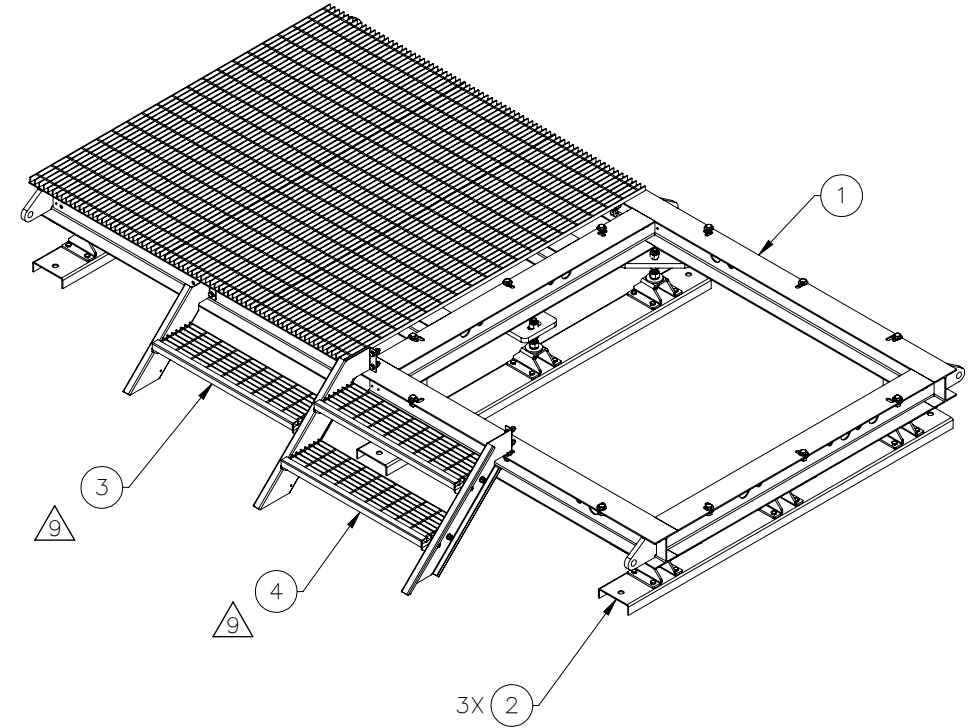

DETAIL A
9 PLCS



ITEM NO.	QTY REQD	PART NUMBER	DESCRIPTION	LENGTH	WEIGHT
1	1	1001-0010-0040	COMBO WIC PLATFORM		1208.68
2	3	1008-0010-0016	3 POINT FOUNDATION ASSY, WITH HARDWARE		111.5
3	1	1003-0000-0020	1-STEP STAIRS KIT, 45 DEGREE		46.0
4	1	1003-0000-0016	2-STEP STAIRS KIT, 45 DEGREE		82.0
5	1	1000-0020-0065	WIC ATTACHING HARDWARE KIT		1723.57

SURFACE FINISH <input checked="" type="checkbox"/> UNLESS OTHERWISE SPECIFIED		UNLESS OTHERWISE SPECIFIED DIMENSIONS ARE IN INCHES		APPROVALS		DATE		 ELECTRO MECHANICAL INDUSTRIES, INC. 11230 NEESESHAW DRIVE HOUSTON, TEXAS 77065 1-800-453-0050	
MATERIAL SEE PARTS LIST		TOLERANCES .0 ± .06 .00 ± .015 .000 ± .005		DRAWN RLWjr		9/27/2018			
THIRD ANGLE PROJECTION 		FRACTIONS ± 1/16		CHECKER P. GUTIERREZ		1/9/2019		TITLE: WIC COMBO GENERATOR PLATFORM GRAVITY MOUNT KIT	
NEXT ASSY USED ON		ANGLES ± .25°		ENGINEER J. BREEN		1/9/2019			
APPLICATIONS		HOLES: DRILLED OR PUNCHED ± 1/32		PRODUCTION JKS		1/10/2019		SIZE B DRAWING NO. 1000-0010-0123 REV 9 SCALE: 1:48 WEIGHT: 2003.31 lbs. SHEET 1 OF 1	
		BURNED ± 1/32							