

THE INFORMATION CONTAINED IN THIS DRAWING IS THE SOLE PROPERTY OF ELECTRO MECHANICAL INDUSTRIES, INC. ANY REPRODUCTION IN PART OR WHOLE WITHOUT THE WRITTEN PERMISSION OF ELECTRO MECHANICAL IND., IS PROHIBITED.

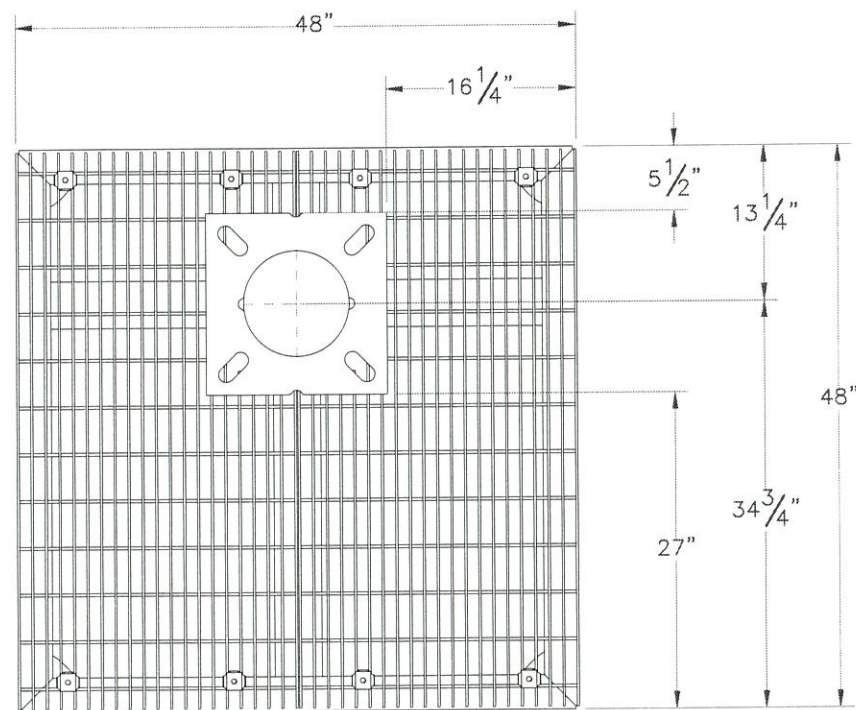

GRATING CLIP  
4 PER PANEL

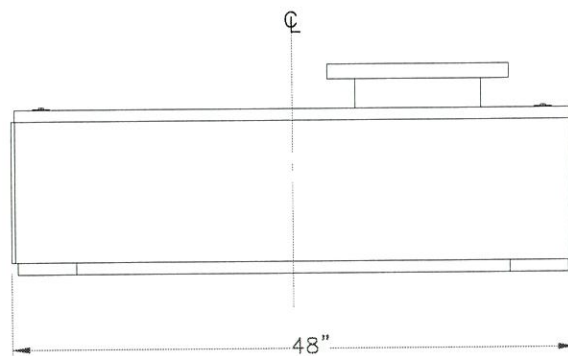
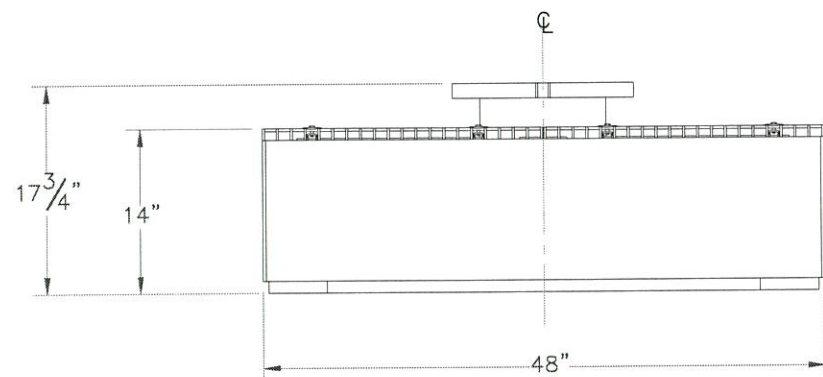
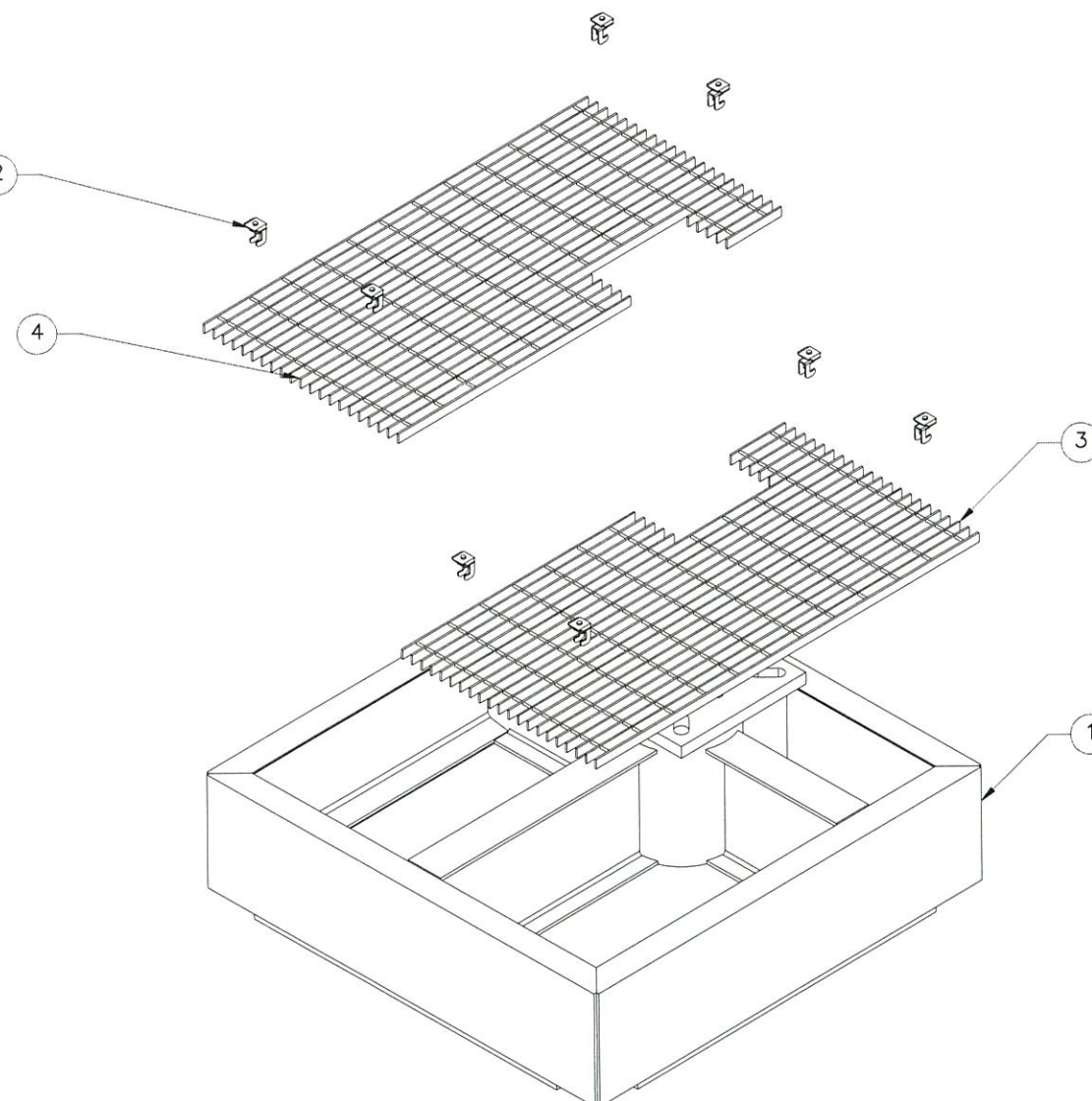

ITEM NO.	QTY REQD	PART NUMBER	DESCRIPTION	LENGTH	WEIGHT
1	1	W-001-843	4' X 4' BALLAST FOUNDATION, WELDMENT		1116.39
2	8	000-MSG-0008	GRATING CLIP, 1", GALV.		0.20
3	1	P-004-069	2' X 4' GRATING, RIGHT SIDE	47 1/2"	52.68
4	1	P-004-068	2' X 4' GRATING, LEFT SIDE	47 1/2"	52.68

SURFACE FINISH <input checked="" type="checkbox"/> UNLESS OTHERWISE SPECIFIED		UNLESS OTHERWISE SPECIFIED DIMENSIONS ARE IN INCHES		APPROVALS	DATE	ELECTRO MECHANICAL INDUSTRIES, INC. 11230 NEESEHAW DRIVE HOUSTON, TEXAS 77065 1-800-453-0050
MATERIAL SEE PARTS LIST		TOLERANCES .0 ± .06 .00 ± .015 .000 ± .005		DRAWN RLW Jr	03.04.2020	
THIRD ANGLE PROJECTION		FRACTIONS ± 1/16		CHECKED <i>F. Mevchun</i> 3/6/2020		SIZE B
NEXT ASSY		ANGLES ± .25°		ENGINEER/DESIGNER <i>F. Mevchun</i> 3/6/2020		
APPLICATIONS		HOLES: DRILLED OR PUNCHED ± 1/32		PRODUCTION <i>JKS</i> 3-9-20		SCALE: 1:16
		BURNED ± 1/32				WEIGHT: 1223.34 lbs.
						SHEET 1 OF 1