

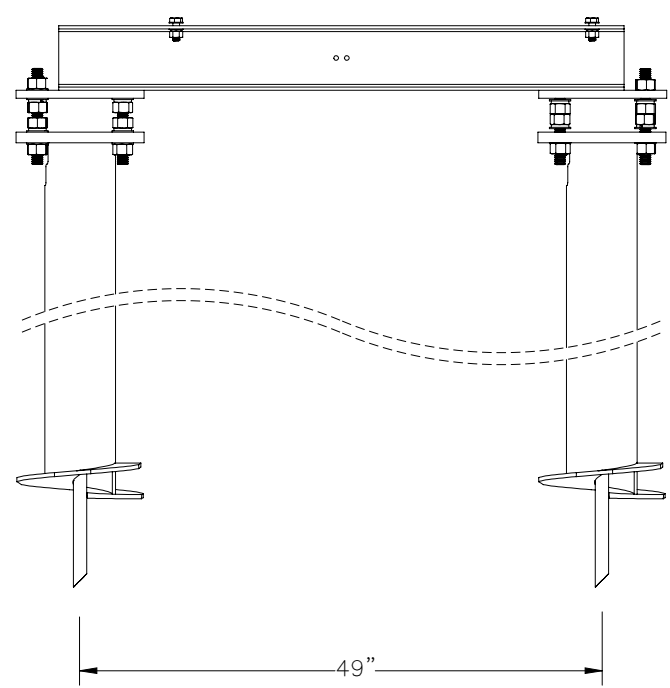

THE INFORMATION CONTAINED IN THIS DRAWING IS THE SOLE PROPERTY OF ELECTRO MECHANICAL INDUSTRIES, INC. ANY REPRODUCTION IN PART OR WHOLE WITHOUT THE WRITTEN PERMISSION OF ELECTRO MECHANICAL IND., IS PROHIBITED.

REVISIONS					
REV.	DCN #	DESCRIPTION	DATE	BY	APPROVED
6	01205	RODENT GUARD P-006-606 ADDED.	01/04/2023	JTR	JPB

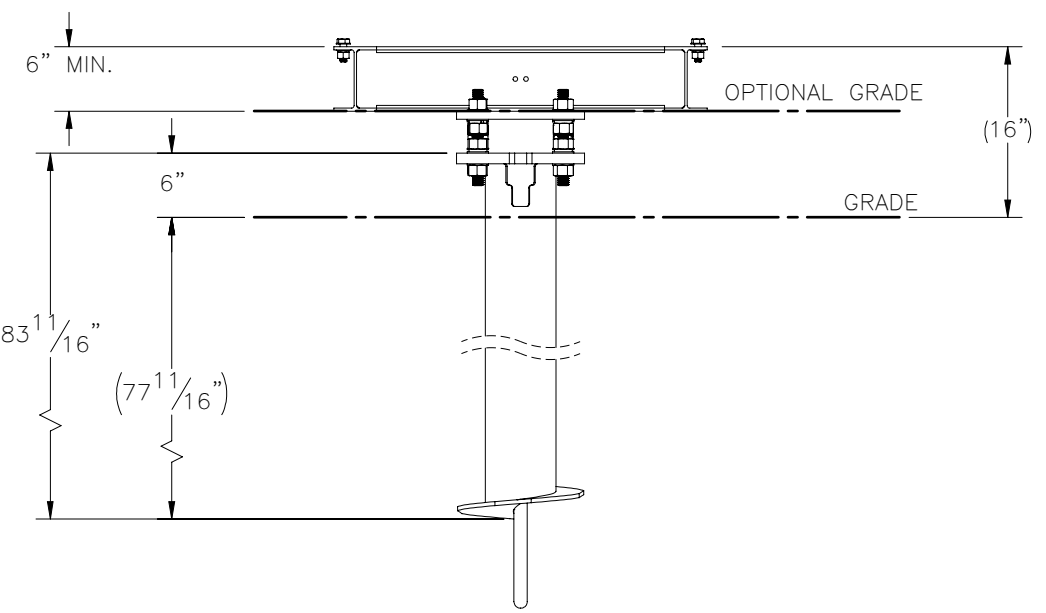
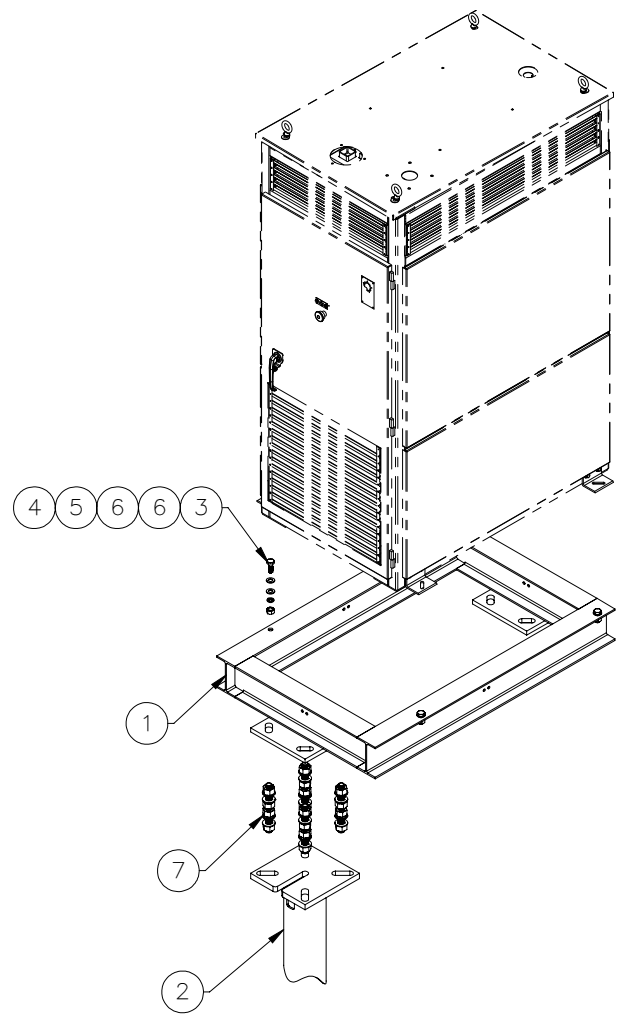
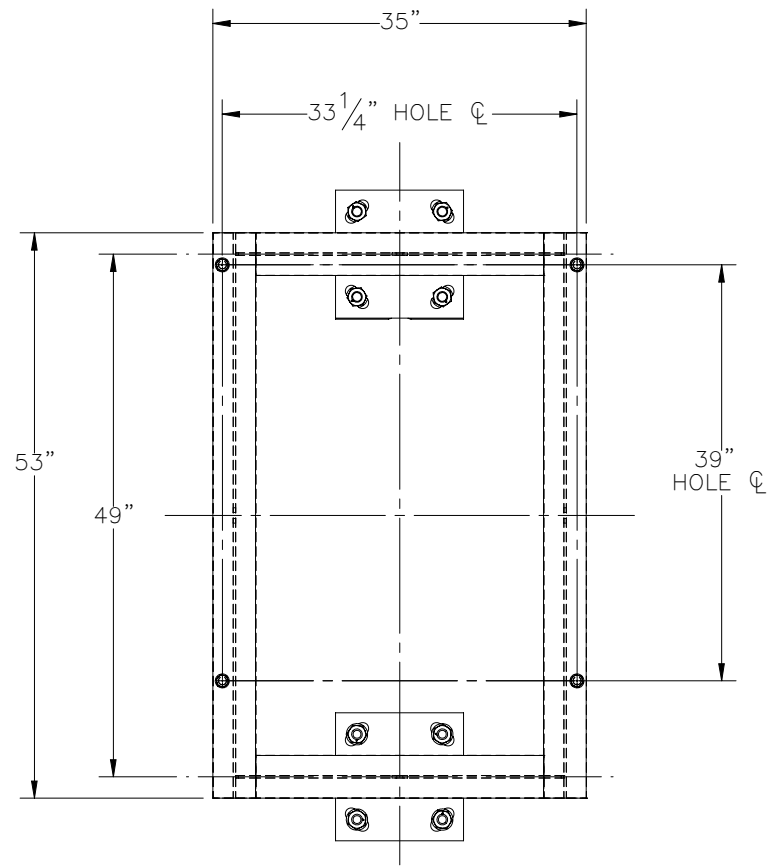

ITEM NO.	QTY REQD	PART NUMBER	DESCRIPTION	LENGTH	WEIGHT
1	1	W-000-460	GENERATOR FRAME WELDMENT		220
2	2	1008-0050-0015	6" X 7', HELICAL, SINGLE STUD OPTION		177.2
3	4	002-0BG-0033	BOLT, HX HD, .625-11UNC X 1.75" LG, ASTM A325, GALV		0.03
4	4	002-0NG-0004	NUT, HX, 0.625-11UNC, GR 2H, GALV		0.12
5	4	002-0LW-G004	WASHER, SPLIT LOCK, .625 INCH, GALV		0.03
6	8	002-0FW-G004	WASHER, FLAT, .625", ASTM F436, GALV		0.03
7	2	1000-0020-0077	QUAD MOUNT LEVELING HARDWARE KIT		15.2
8	1	P-006-606	RODENT GUARD	36"	2.7

NOTES:
 1. OPTIONAL PLATE PROVIDED IF REQUIRED FOR GENERATOR.

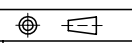
SURFACE FINISH <input checked="" type="checkbox"/> UNLESS OTHERWISE SPECIFIED		UNLESS OTHERWISE SPECIFIED DIMENSIONS ARE IN INCHES		APPROVALS		DATE		 ELECTRO MECHANICAL INDUSTRIES, INC. 11230 NEESESHAW DRIVE HOUSTON, TEXAS 77065 1-800-453-0050	
MATERIAL SEE PARTS LIST		TOLERANCES		DRAWN RLWjr		3/6/2018		TITLE: GENERATOR PLATFORM	
THIRD ANGLE PROJECTION 		.0 ±.06 .00 ±.015 .000 ±.005		CHECKER J. BUSHMAN		6/20/2018		SIZE B	
NEXT ASSY		FRACTIONS ± 1/16		ENGINEER J. BUSHMAN		6/20/2018		DRAWING NO. 1000-0010-0075	
USED ON		ANGLES ±.25°		PRODUCTION J. SUNDERLAND		6/20/2018		REV 6	
APPLICATIONS		HOLES: DRILLED OR PUNCHED ±1/32		SCALE: 1:18		WEIGHT: 608.6 lbs.		SHEET 1 OF 1	
		BURNED ±1/32							